

Interaction Diagram - Tied Reinforced Concrete Column (Using CSA A23.3-14)

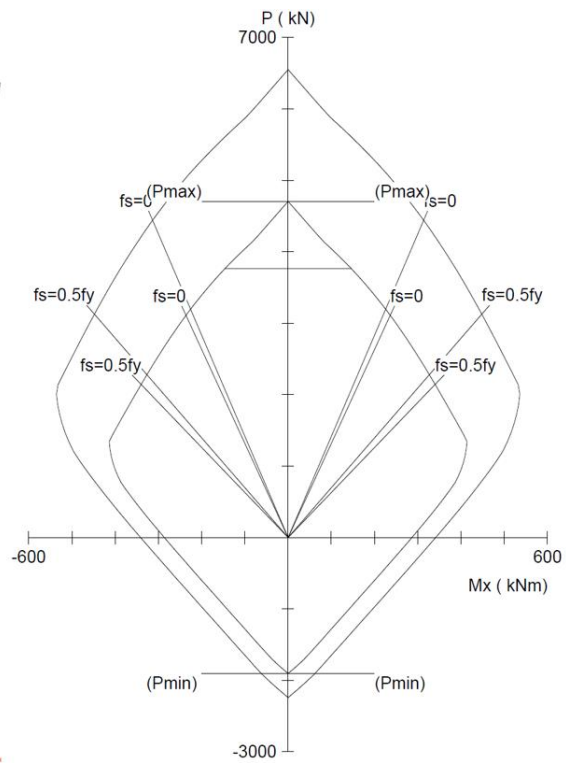

Interaction Diagram - Tied Reinforced Concrete Column

Develop an interaction diagram for the square tied concrete column shown in the figure below about the x-axis using CSA A23.3-14 provisions. Determine six control points on the interaction diagram and compare the calculated values in the Reference and with exact values from the complete interaction diagram generated by [spColumn](#) engineering software program from [StructurePoint](#).

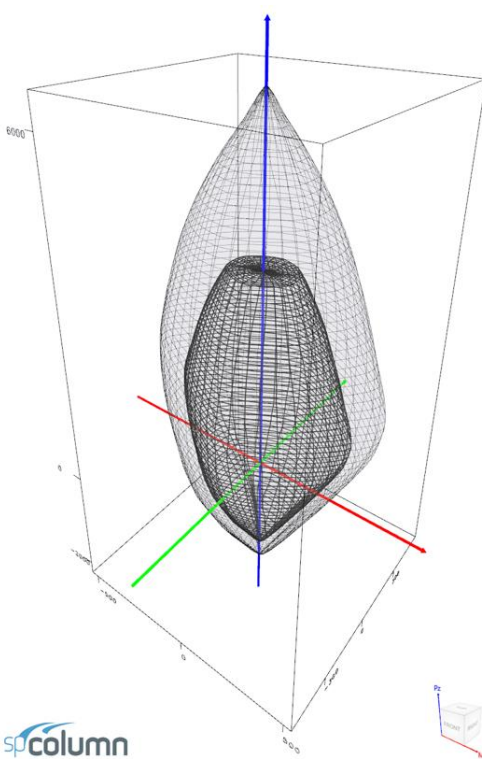
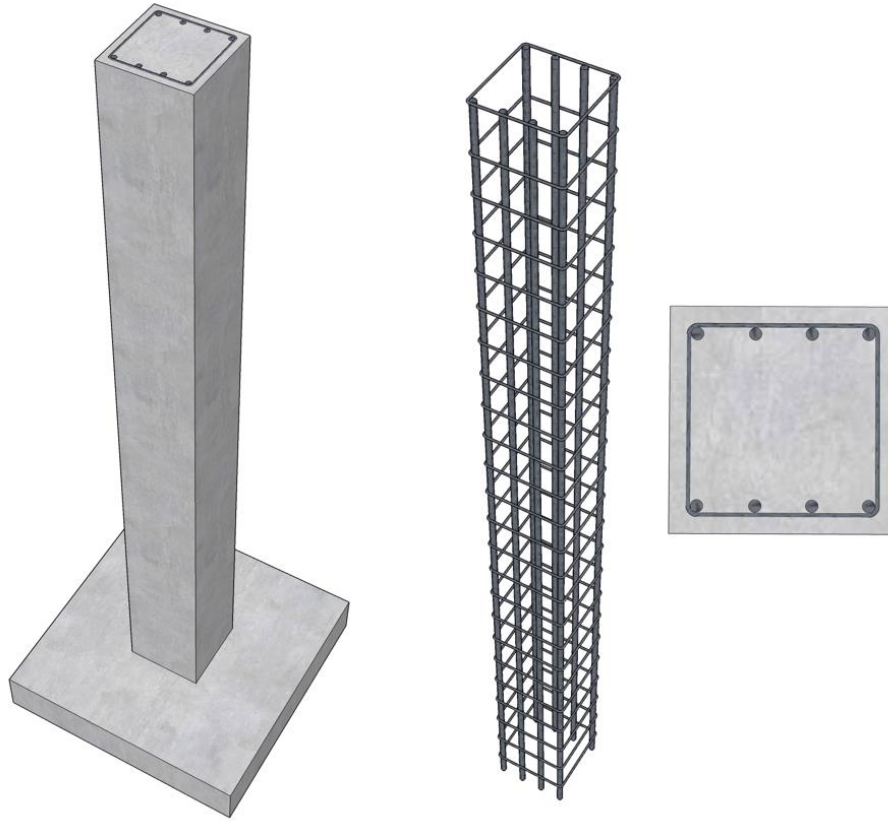
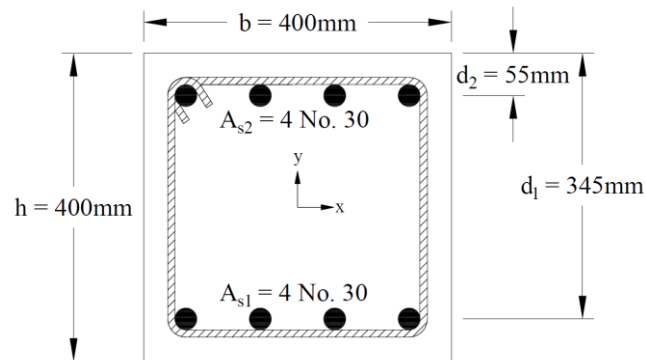

Figure 1 – Reinforced Concrete Column Cross-Section

Contents

1. Pure Compression	3
1.1. Nominal axial resistance at zero eccentricity	3
1.2. Factored axial load resistance at zero eccentricity	3
1.3. Maximum factored axial load resistance	3
2. Bar Stress Near Tension Face of Member Equal to Zero, ($\epsilon_s = f_s = 0$)	4
2.1. c , a , and strains in the reinforcement	4
2.2. Forces in the concrete and steel.....	4
2.3. P_r and M_r	5
3. Bar Stress Near Tension Face of Member Equal to $0.5 f_y$, ($f_s = -0.5 f_y$).....	6
3.1. c , a , and strains in the reinforcement	6
3.2. Forces in the concrete and steel.....	6
3.3. P_r and M_r	7
4. Bar Stress Near Tension Face of Member Equal to f_y , ($f_s = -f_y$).....	8
4.1. c , a , and strains in the reinforcement	8
4.2. Forces in the concrete and steel.....	9
4.3. P_r and M_r	9
5. Pure Bending.....	10
5.1. c , a , and strains in the reinforcement	10
5.2. Forces in the concrete and steel.....	10
5.3. P_r and M_r	11
6. Pure Tension.....	12
6.1. Strength under pure axial tension (P_{rt}).....	12
6.2. Corresponding Moment (M_{rt}).....	12
7. Column Interaction Diagram - spColumn Software.....	13
8. Summary and Comparison of Design Results.....	19
9. Conclusions & Observations	20

Code

Design of Concrete Structures (CSA A23.3-14)

Reference

Reinforced Concrete Mechanics and Design, 1st Canadian Edition, 2000, James MacGregor and Fred Michael
Bratlett, Prentice Hall Canada Inc.

Design Data

$$f_c' = 35 \text{ MPa}$$

$$f_y = 400 \text{ MPa}$$

Cover = 55 mm to the center of the reinforcement

Column 400 mm x 400 mm

Top reinforcement = 4 No. 30

Bottom reinforcement = 4 No. 30

Solution

Use the traditional hand calculations approach to generate the interaction diagram for the concrete column section shown above by determining the following six control points:

Point 1: Pure compression

Point 2: Bar stress near tension face of member equal to zero, ($f_s = 0$)

Point 3: Bar stress near tension face of member equal to $0.5 f_y$ ($f_s = -0.5 f_y$)

Point 4: Bar stress near tension face of member equal to f_y ($f_s = -f_y$)

Point 5: Pure bending

Point 6: Pure tension

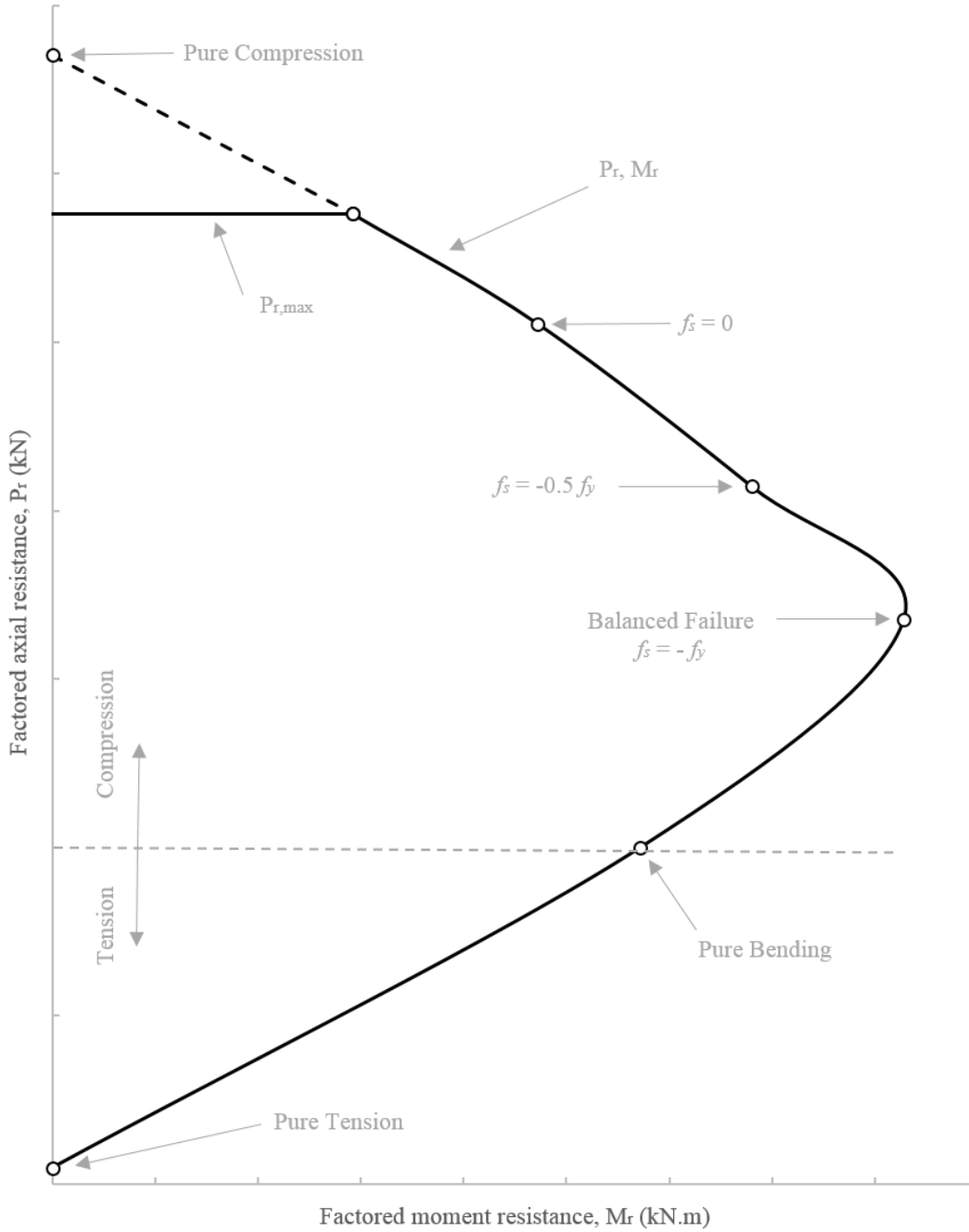

Figure 2 – Control Points

1. Pure Compression

1.1. Nominal axial resistance at zero eccentricity

$$P_o = \alpha_1 f'_c (A_g - A_{st}) + f_y A_{st}$$

$$P_o = 0.798 \times 35 \times (400 \times 400 - 8 \times 700) + 400 \times 8 \times 700 = 6550 \text{ kN}$$

$$\text{Where } \alpha_1 = 0.85 - 0.0015 f'_c \geq 0.67$$

CSA A23.3-14 (Equation 10.1)

$$\alpha_1 = 0.85 - 0.0015 \times 35 = 0.798 \geq 0.67$$

1.2. Factored axial load resistance at zero eccentricity

Since this column is a tied column with steel strain in compression:

$$P_{ro} = \alpha_1 \phi_c f'_c (A_g - A_{st}) + \phi_s f_y A_{st}$$

CSA A23.3-14 (Equation 10.11)

$$P_{ro} = 0.798 \times 0.65 \times 35 \times (400 \times 400 - 8 \times 700) + 0.85 \times 400 \times 8 \times 700 = 4705 \text{ kN}$$

Where:

$$\phi_c = 0.65$$

CSA A23.3-14 (8.4.2)

$$\phi_s = 0.85$$

CSA A23.3-14 (8.4.3(a))

1.3. Maximum factored axial load resistance

$$P_{r,max} = (0.2 + 0.002h) P_{ro} \leq 0.80 P_{ro}$$

CSA A23.3-14 (Equation 10.9)

$$P_{r,max} = (0.2 + 0.002 \times 400) \times 4705 = 4705 \text{ kN} \leq 0.80 P_{ro} = 0.80 \times 4705 = 3764 \text{ kN}$$

$$P_{r,max} = 3764 \text{ kN}$$

2. Bar Stress Near Tension Face of Member Equal to Zero, ($\epsilon_s = f_s = 0$)

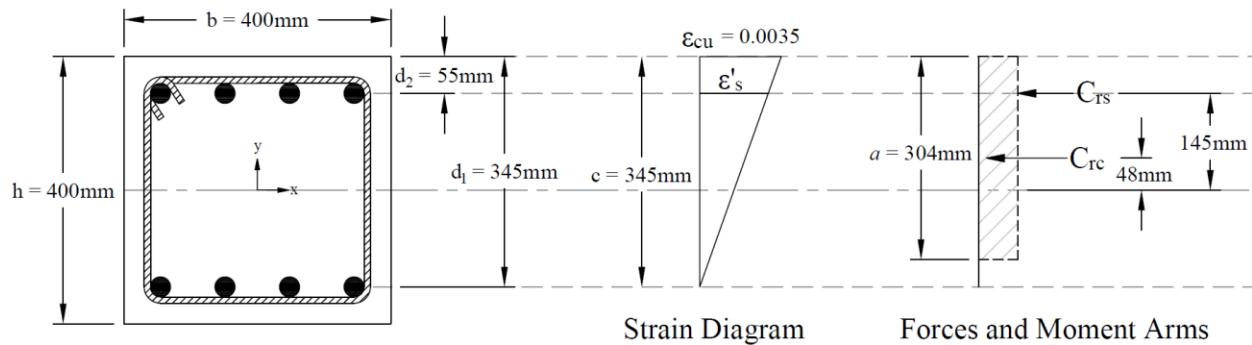

Figure 3 – Strains, Forces, and Moment Arms ($\epsilon_t = f_s = 0$)

Strain ϵ_s is zero in the extreme layer of tension steel. This case is considered when calculating an interaction diagram because it marks the change from compression lap splices being allowed on all longitudinal bars, to the more severe requirement of tensile lap splices. CSA A23.3-14 (12.15 and 16)

2.1. c, a, and strains in the reinforcement

$$c = d_1 = 345 \text{ mm}$$

Where c is depth of the neutral axis measured from the compression edge of the column section.

CSA A23.3-14 (3.2)

$$a = \beta_1 \times c = 0.883 \times 345 = 304 \text{ mm}$$

CSA A23.3-14 (10.1.7)

Where:

a = Depth of equivalent rectangular stress block

CSA A23.3-14 (3.2)

$$\beta_1 = 0.97 - 0.0025 \times f'_c = 0.97 - 0.0025 \times 35 = 0.883 > 0.67$$

CSA A23.3-14 (Equation 10.2)

$$\epsilon_s = 0$$

$$\phi_c = 0.65$$

CSA A23.3-14 (8.4.2)

$$\phi_s = 0.85$$

CSA A23.3-14 (8.4.3(a))

$$\epsilon_{cu} = 0.0035$$

CSA A23.3-14 (10.1.3)

$$\epsilon'_s = (c - d_2) \times \frac{\epsilon_{cu}}{c} = (345 - 55) \times \frac{0.0035}{345} = 0.00294 \text{ (Compression)} > \epsilon_y = \frac{F_y}{E_s} = \frac{400}{200,000} = 0.002$$

2.2. Forces in the concrete and steel

$$C_{rc} = \alpha_1 \times \phi_c \times f'_c \times a \times b = 0.798 \times 0.65 \times 35 \times 304 \times 400 = 2210 \text{ kN}$$

CSA A23.3-14 (10.1.7)

$$f_s = 0 \text{ kN} \rightarrow T_{rs} = \phi_s \times f_s \times A_{s1} = 0 \text{ kN}$$

Since $\varepsilon'_s > \varepsilon_y \rightarrow$ compression reinforcement has yielded

$$\therefore f'_s = f_y = 400 \text{ MPa}$$

The area of the reinforcement in this layer has been included in the area (ab) used to compute C_c . As a result, it is necessary to subtract $\alpha_1 \phi_c f'_c$ from $\phi_s f'_s$ before computing C_{rs} :

$$C_{rs} = (\phi_s \times f'_s - \alpha_1 \times \phi_c \times f'_c) \times A_{s2} = (0.85 \times 400 - 0.798 \times 0.65 \times 35) \times 2800 = 901 \text{ kN}$$

2.3. P_r and M_r

$$P_r = C_{rc} + C_{rs} - T_{rs} = 2210 + 901 - 0 = 3111 \text{ kN}$$

$$M_r = C_{rc} \times \left(\frac{h}{2} - \frac{a}{2} \right) + C_{rs} \times \left(\frac{h}{2} - d_2 \right) + T_{rs} \times \left(d_1 - \frac{h}{2} \right)$$

$$M_r = 2210 \times \left(\frac{400}{2} - \frac{304}{2} \right) + 901 \times \left(\frac{400}{2} - 55 \right) + 0 \times \left(345 - \frac{400}{2} \right) = 236 \text{ kN.m}$$

3. Bar Stress Near Tension Face of Member Equal to $0.5 f_y$, ($f_s = -0.5 f_y$)

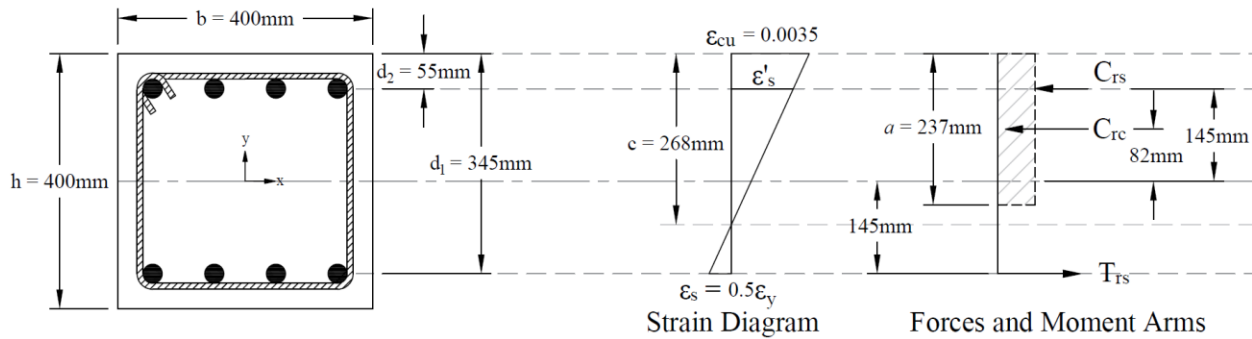

Figure 4 – Strains, Forces, and Moment Arms ($f_s = -0.5 f_y$)

3.1. c, a, and strains in the reinforcement

$$\varepsilon_y = \frac{F_y}{E_s} = \frac{400}{200,000} = 0.002$$

$$\varepsilon_s = \frac{\varepsilon_y}{2} = \frac{0.002}{2} = 0.001 < \varepsilon_y \rightarrow \text{tension reinforcement has not yielded}$$

$$\phi_c = 0.65$$

CSA A23.3-14 (8.4.2)

$$\phi_s = 0.85$$

CSA A23.3-14 (8.4.3(a))

$$\varepsilon_{cu} = 0.0035$$

CSA A23.3-14 (10.1.3)

$$c = \frac{d_1}{\varepsilon_s + \varepsilon_{cu}} \times \varepsilon_{cu} = \frac{345}{0.001 + 0.0035} \times 0.0035 = 268 \text{ mm}$$

Where c is depth of the neutral axis measured from the compression edge of the column section.

CSA A23.3-14 (3.2)

$$a = \beta_1 \times c = 0.883 \times 268 = 237 \text{ mm}$$

CSA A23.3-14 (10.1.7)

Where:

a = Depth of equivalent rectangular stress block

CSA A23.3-14 (3.2)

$$\beta_1 = 0.97 - 0.0025 \times f'_c = 0.97 - 0.0025 \times 35 = 0.883 > 0.67$$

CSA A23.3-14 (Equation 10.2)

$$\varepsilon'_s = (c - d_2) \times \frac{\varepsilon_{cu}}{c} = (268 - 55) \times \frac{0.0035}{268} = 0.00278 \text{ (Compression)} > \varepsilon_y$$

3.2. Forces in the concrete and steel

$$C_{rc} = \alpha_1 \times \phi_c \times f'_c \times a \times b = 0.798 \times 0.65 \times 35 \times 237 \times 400 = 1719 \text{ kN}$$

CSA A23.3-14 (10.1.7)

$$f_s = \varepsilon_s \times E_s = 0.001 \times 200,000 = 200 \text{ MPa}$$

$$T_{rs} = \phi_s \times f_s \times A_{s1} = 0.85 \times 200 \times 2800 = 476 \text{ kN}$$

Since $\varepsilon'_s > \varepsilon_y \rightarrow$ compression reinforcement has yielded

$$\therefore f'_s = f_y = 400 \text{ MPa}$$

The area of the reinforcement in this layer has been included in the area (ab) used to compute C_c . As a result, it is necessary to subtract $\alpha_1 \phi_c f'_c$ from $\phi_s f'_s$ before computing C_{rs} :

$$C_{rs} = (\phi_s \times f'_s - \alpha_1 \times \phi_c \times f'_c) \times A_{s2} = (0.85 \times 400 - 0.798 \times 0.65 \times 35) \times 2800 = 901 \text{ kN}$$

3.3. P_r and M_r

$$P_r = C_{rc} + C_{rs} - T_{rs} = 1719 + 901 - 476 = 2144 \text{ kN}$$

$$M_r = C_{rc} \times \left(\frac{h}{2} - \frac{a}{2} \right) + C_{rs} \times \left(\frac{h}{2} - d_2 \right) + T_{rs} \times \left(d_1 - \frac{h}{2} \right)$$

$$M_r = 1719 \times \left(\frac{400}{2} - \frac{237}{2} \right) + 901 \times \left(\frac{400}{2} - 55 \right) + 476 \times \left(345 - \frac{400}{2} \right) = 340 \text{ kN.m}$$

4. Bar Stress Near Tension Face of Member Equal to f_y , ($f_s = -f_y$)

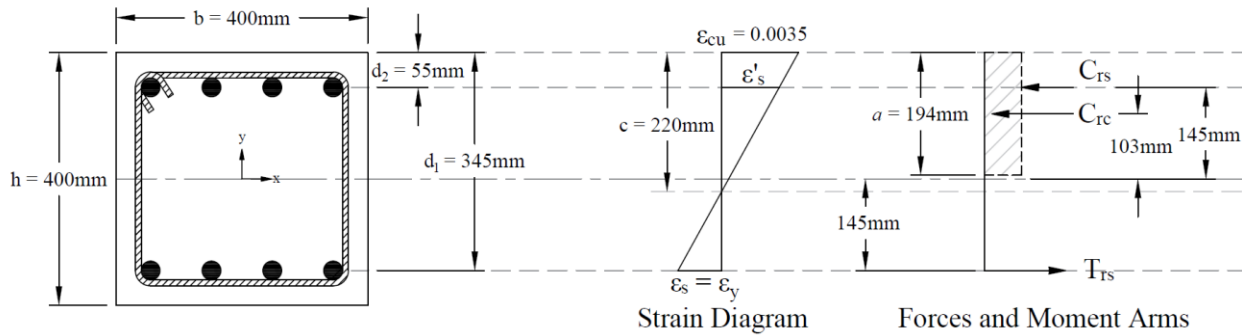

Figure 5 – Strains, Forces, and Moment Arms ($f_s = -f_y$)

This strain distribution is called the balanced failure case and the compression-controlled strain limit. It marks the change from compression failures originating by crushing of the compression surface of the section, to tension failures initiated by yield of longitudinal reinforcement.

4.1. c , a , and strains in the reinforcement

$$\varepsilon_y = \frac{F_y}{E_s} = \frac{400}{200,000} = 0.002$$

$$\varepsilon_s = \varepsilon_y = 0.002 \rightarrow \text{tension reinforcement has yielded}$$

$$\phi_c = 0.65 \quad \text{CSA A23.3-14 (8.4.2)}$$

$$\phi_s = 0.85 \quad \text{CSA A23.3-14 (8.4.3(a))}$$

$$\varepsilon_{cu} = 0.0035 \quad \text{CSA A23.3-14 (10.1.3)}$$

$$c = \frac{d_1}{\varepsilon_s + \varepsilon_{cu}} \times \varepsilon_{cu} = \frac{345}{0.002 + 0.0035} \times 0.0035 = 220 \text{ mm}$$

Where c is depth of the neutral axis measured from the compression edge of the column section.

$$\text{CSA A23.3-14 (3.2)}$$

$$a = \beta_1 \times c = 0.883 \times 220 = 194 \text{ mm} \quad \text{CSA A23.3-14 (10.1.7)}$$

Where:

$$a = \text{Depth of equivalent rectangular stress block} \quad \text{CSA A23.3-14 (3.2)}$$

$$\beta_1 = 0.97 - 0.0025 \times f'_c = 0.97 - 0.0025 \times 35 = 0.883 > 0.67 \quad \text{CSA A23.3-14 (Equation 10.2)}$$

$$\varepsilon'_s = (c - d_2) \times \frac{\varepsilon_{cu}}{c} = (220 - 55) \times \frac{0.0035}{220} = 0.00262 \text{ (Compression)} > \varepsilon_y$$

4.2. Forces in the concrete and steel

$$C_{rc} = \alpha_1 \times \phi_c \times f'_c \times a \times b = 0.798 \times 0.65 \times 35 \times 194 \times 400 = 1406 \text{ kN}$$

CSA A23.3-14 (10.1.7)

$$f_s = f_y = 400 \text{ MPa}$$

$$T_{rs} = \phi_s \times f_s \times A_{s1} = 0.85 \times 400 \times 2800 = 952 \text{ kN}$$

Since $\epsilon'_s > \epsilon_y \rightarrow$ compression reinforcement has yielded

$$\therefore f'_s = f_y = 400 \text{ MPa}$$

The area of the reinforcement in this layer has been included in the area (ab) used to compute C_c . As a result, it is necessary to subtract $\alpha_1 \phi_c f'_c$ from $\phi_s f'_s$ before computing C_{rs} :

$$C_{rs} = (\phi_s \times f'_s - \alpha_1 \times \phi_c \times f'_c) \times A_{s2} = (0.85 \times 400 - 0.798 \times 0.65 \times 35) \times 2800 = 901 \text{ kN}$$

4.3. P_r and M_r

$$P_r = C_{rc} + C_{rs} - T_{rs} = 1406 + 901 - 952 = 1355 \text{ kN}$$

$$M_r = C_{rc} \times \left(\frac{h}{2} - \frac{a}{2} \right) + C_{rs} \times \left(\frac{h}{2} - d_2 \right) + T_{rs} \times \left(d_1 - \frac{h}{2} \right)$$

$$M_r = 1406 \times \left(\frac{400}{2} - \frac{194}{2} \right) + 901 \times \left(\frac{400}{2} - 55 \right) + 952 \times \left(345 - \frac{400}{2} \right) = 414 \text{ kN.m}$$

5. Pure Bending

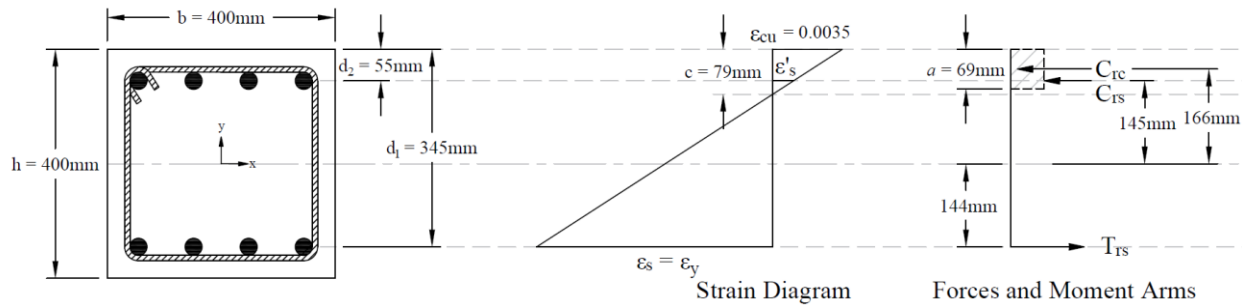

Figure 6 – Strains, Forces, and Moment Arms (Pure Moment)

This corresponds to the case where the factored axial load resistance, P_r , is equal to zero. Iterative procedure is used to determine the factored moment resistance as follows:

5.1. c , a , and strains in the reinforcement

Try $c = 78.55$ mm

Where c is depth of the neutral axis measured from the compression edge of the column section.

CSA A23.3-14 (3.2)

$$a = \beta_1 \times c = 0.883 \times 78.55 = 69 \text{ mm}$$

CSA A23.3-14 (10.1.7)

Where:

$$\beta_1 = 0.97 - 0.0025 \times f'_c = 0.97 - 0.0025 \times 35 = 0.883 > 0.67$$

CSA A23.3-14 (Equation 10.2)

$$\epsilon_{cu} = 0.0035$$

CSA A23.3-14 (10.1.3)

$$\epsilon_y = \frac{F_y}{E_s} = \frac{400}{200,000} = 0.002$$

$$\epsilon_s = (d_1 - c) \times \frac{\epsilon_{cu}}{c} = (345 - 78.55) \times \frac{0.0035}{78.55} = 0.01187 \text{ (Tension)} > \epsilon_y \rightarrow \text{tension reinforcement has yielded}$$

$$\phi_c = 0.65$$

CSA A23.3-14 (8.4.2)

$$\phi_s = 0.85$$

CSA A23.3-14 (8.4.3(a))

$$\epsilon'_s = (c - d_2) \times \frac{\epsilon_{cu}}{c} = (78.55 - 55) \times \frac{0.0035}{78.55} = 0.00105 \text{ (Compression)} < \epsilon_y$$

5.2. Forces in the concrete and steel

$$C_{rc} = \alpha_1 \times \phi_c \times f'_c \times a \times b = 0.798 \times 0.65 \times 35 \times 69 \times 400 = 503 \text{ kN}$$

CSA A23.3-14 (10.1.7)

$$f_s = f_y = 400 \text{ MPa}$$

$$T_{rs} = \phi_s \times f_s' \times A_{s1} = 0.85 \times 400 \times 2800 = 952 \text{ kN}$$

Since $\varepsilon_s' < \varepsilon_y$ → compression reinforcement has not yielded

$$\therefore f_s' = \varepsilon_s' \times E_s = 0.00105 \times 200,000 = 210 \text{ MPa}$$

The area of the reinforcement in this layer has been included in the area (ab) used to compute C_c . As a result, it is necessary to subtract $\alpha_1 \phi_c f_c'$ from $\phi_s f_s'$ before computing C_{rs} :

$$C_{rs} = (\phi_s \times f_s' - \alpha_1 \times \phi_c \times f_c') \times A_{s2} = (0.85 \times 210 - 0.798 \times 0.65 \times 35) \times 2800 = 449 \text{ kN}$$

5.3. P_r and M_r

$$P_r = C_{rc} + C_{rs} - T_{rs} = 503 + 449 - 952 \approx 0 \text{ kN}$$

The assumption that $c = 78.55 \text{ mm}$ is correct

$$M_r = C_{rc} \times \left(\frac{h}{2} - \frac{a}{2} \right) + C_{rs} \times \left(\frac{h}{2} - d_2 \right) + T_{rs} \times \left(d_1 - \frac{h}{2} \right)$$

$$M_r = 503 \times \left(\frac{400}{2} - \frac{69}{2} \right) + 449 \times \left(\frac{400}{2} - 55 \right) + 952 \times \left(345 - \frac{400}{2} \right) = 286 \text{ kN.m}$$

6. Pure Tension

The final loading case to be considered is concentric axial tension. The strength under pure axial tension is computed by assuming that the section is completely cracked through and subjected to a uniform strain greater than or equal to the yield strain in tension. The strength under such a loading is equal to the yield strength of the reinforcement in tension.

6.1. Strength under pure axial tension (P_{rt})

$$P_{rt} = \phi_s \times f_y \times (A_{s1} + A_{s2}) = 0.85 \times 400 \times (2800 + 2800) = 1904 \text{ kN}$$

6.2. Corresponding Moment (M_{rt})

Since the section is symmetrical

$$M_{rt} = 0 \text{ kN.m}$$

7. Column Interaction Diagram - spColumn Software

spColumn program performs the analysis of the reinforced concrete section conforming to the provisions of the Strength Design Method and Unified Design Provisions with all conditions of strength satisfying the applicable conditions of equilibrium and strain compatibility. For this column section, we ran in investigation mode with control points using the CSA A23.3-14. In lieu of using program shortcuts, spSection (Figure 9) was used to place the reinforcement and define the cover to illustrate handling of irregular shapes and unusual bar arrangement.

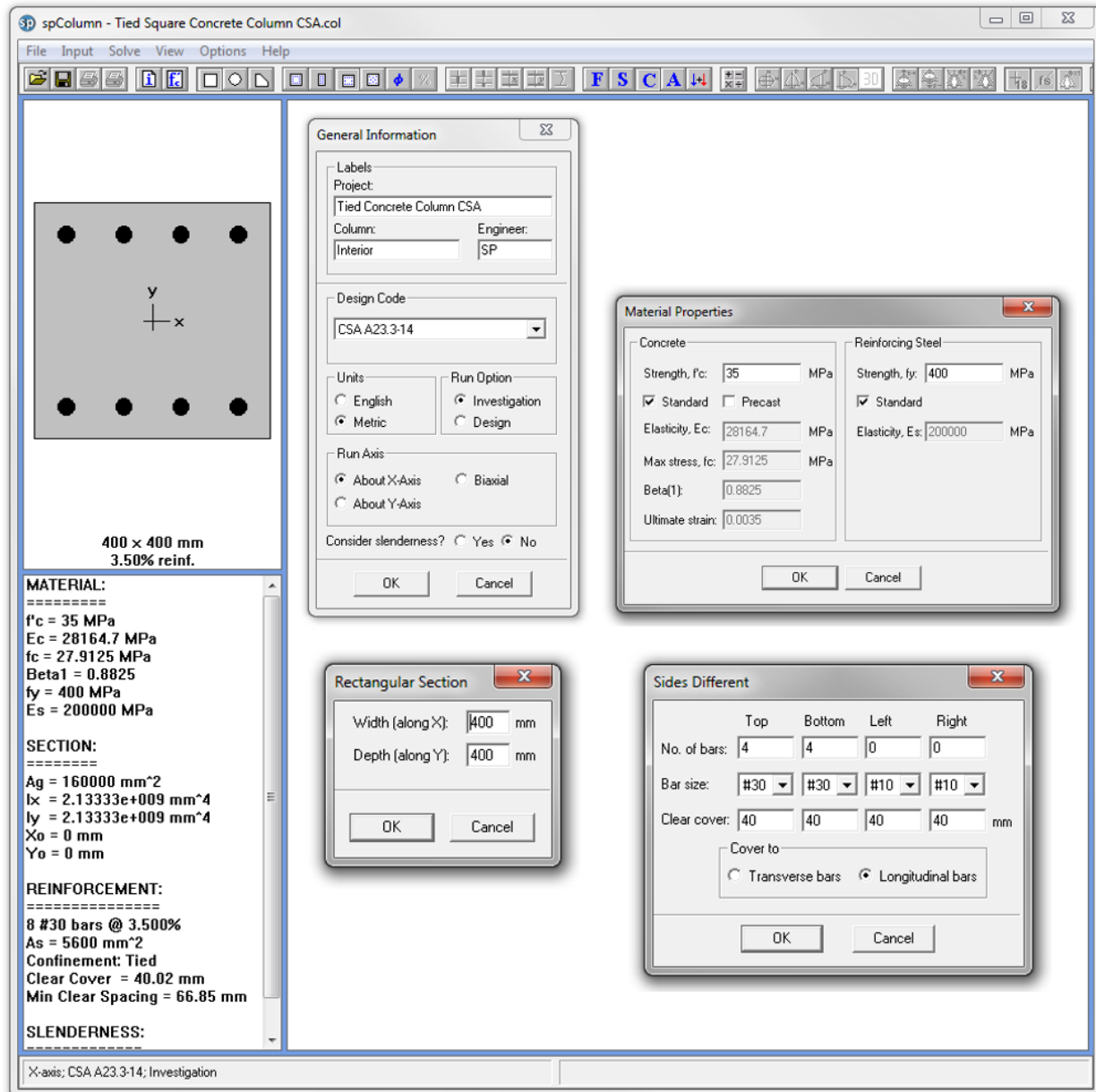

Figure 7 – Generating spColumn Model

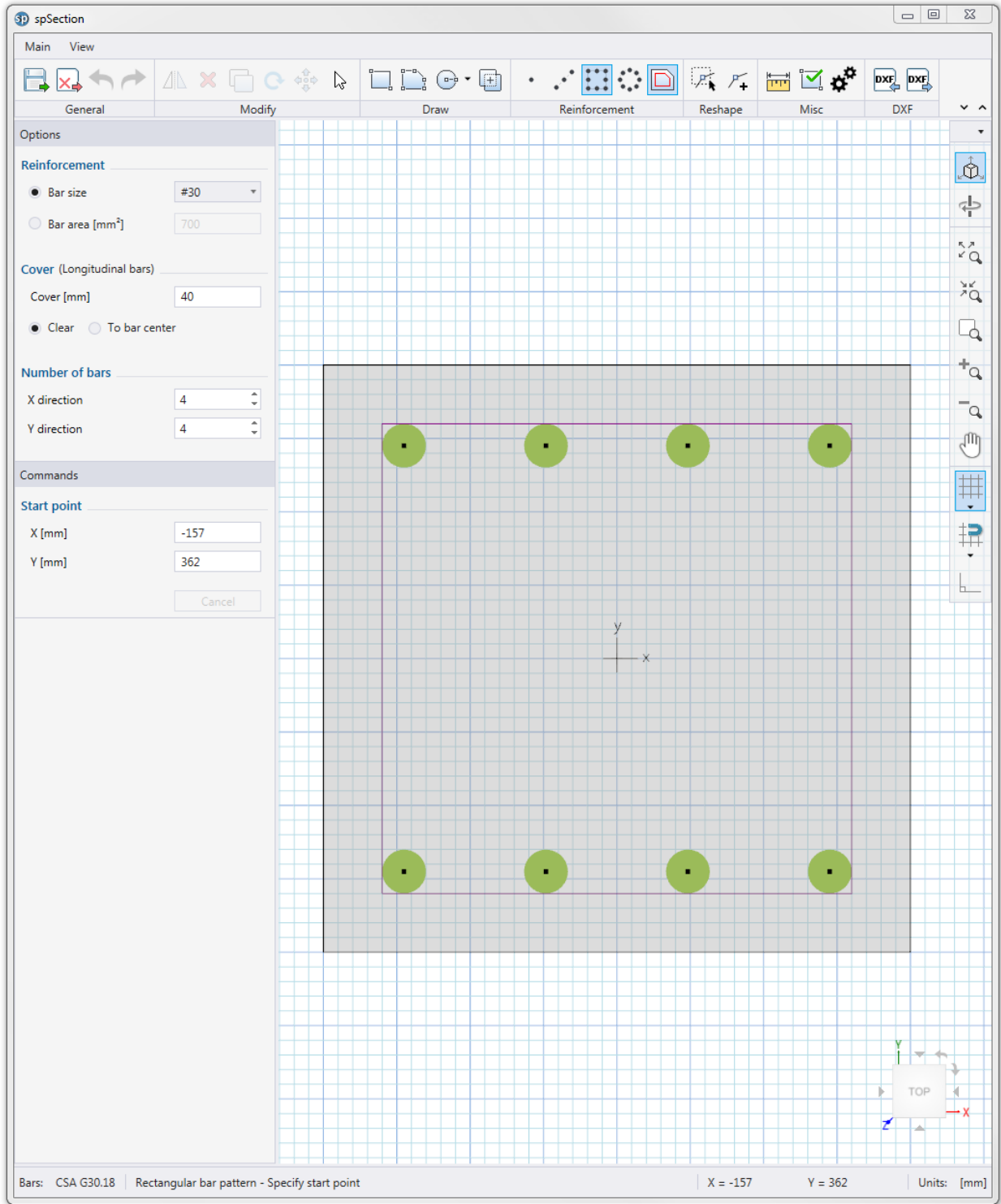

Figure 8 – spColumn Model Editor (spSection)

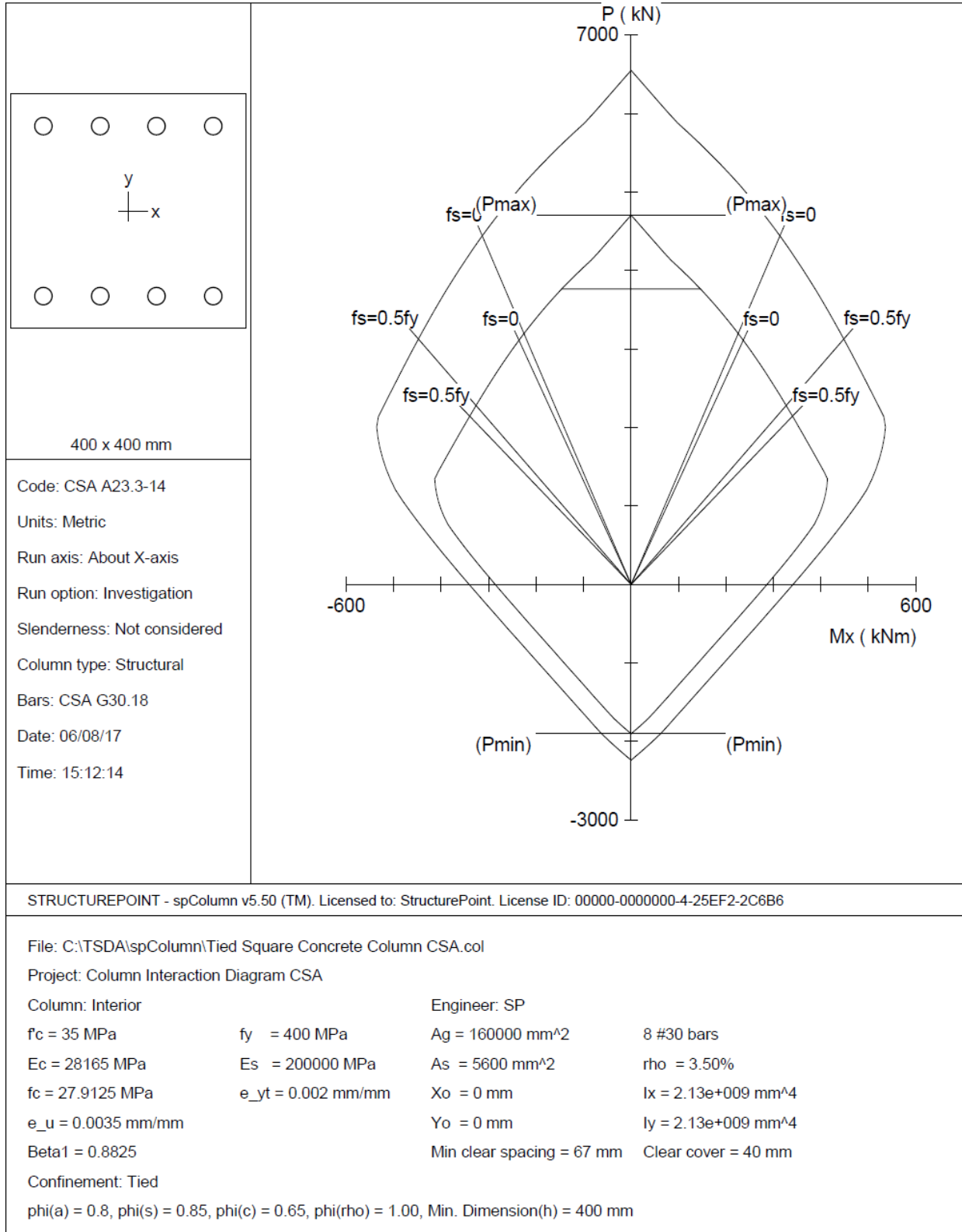

Figure 9 – Column Section Interaction Diagram about the X-Axis (spColumn)

STRUCTUREPOINT - spColumn v5.50 (TM)
Licensed to: StructurePoint. License ID: 00000-00000000-4-25EF2-2C6B6
C:\TSDA\spColumn\Tied Square Concrete Column CSA.col

Page 1
06/08/17
03:11 PM

```

                oooooo          o
                oo   oo          oo
ooooo  oooooo  oo          oooooo  oo   oo   ooooooooooooo  oooooo
oo   o  oo   oo  oo          oo   oo  oo          oo   oo   oo   oo   oo   oo
oo          oo   oo  oo          oo   oo  oo          oo   oo   oo   oo   oo   oo
oooooo  oo   oo  oo          oo   oo  oo          oo   oo   oo   oo   oo   oo
o   oo  oo          oo          oo   oo  oo          oo   oo   oo   oo   oo   oo
ooooo  oo          oooooo  oooooo  oo          oooooo  o   oo   oo   oo   oo   oo (TM)

```

```

=====
                        spColumn v5.50 (TM)
Computer program for the Strength Design of Reinforced Concrete Sections
Copyright © 1988-2016, STRUCTUREPOINT, LLC.
All rights reserved
=====

```

Licensee stated above acknowledges that STRUCTUREPOINT (SP) is not and cannot be responsible for either the accuracy or adequacy of the material supplied as input for processing by the spColumn computer program. Furthermore, STRUCTUREPOINT neither makes any warranty expressed nor implied with respect to the correctness of the output prepared by the spColumn program. Although STRUCTUREPOINT has endeavored to produce spColumn error free the program is not and cannot be certified infallible. The final and only responsibility for analysis, design and engineering documents is the licensee's. Accordingly, STRUCTUREPOINT disclaims all responsibility in contract, negligence or other tort for any analysis, design or engineering documents prepared in connection with the use of the spColumn program.

STRUCTUREPOINT - spColumn v5.50 (TM)
Licensed to: StructurePoint. License ID: 00000-0000000-4-25EF2-2C6B6
C:\TSDA\spColumn\Tied Square Concrete Column CSA.col

Page 2
06/08/17
03:11 PM

General Information:

```

=====
File Name: C:\TSDA\spColumn\Tied Square Concrete Column CSA.col
Project: Column Interaction Diagram CSA
Column: Interior Engineer: SP
Code: CSA A23.3-14 Units: Metric

Run Option: Investigation Slenderness: Not considered
Run Axis: X-axis Column Type: Structural
    
```

Material Properties:

```

=====
Concrete: Standard Steel: Standard
f'c = 35 MPa fy = 400 MPa
Ec = 28164.7 MPa Es = 200000 MPa
fc = 27.9125 MPa Eps_yt = 0.002 mm/mm
Eps_u = 0.0035 mm/mm
Beta1 = 0.8825
    
```

Section:

```

=====
Rectangular: Width = 400 mm Depth = 400 mm

Gross section area, Ag = 160000 mm^2
Ix = 2.13333e+009 mm^4 Iy = 2.13333e+009 mm^4
rx = 115.47 mm ry = 115.47 mm
Xo = 0 mm Yo = 0 mm
    
```

Reinforcement:

```

=====
Bar Set: CSA G30.18
Size Diam (mm) Area (mm^2) Size Diam (mm) Area (mm^2) Size Diam (mm) Area (mm^2)
-----
# 10 11 100 # 15 16 200 # 20 20 300
# 25 25 500 # 30 30 700 # 35 36 1000
# 45 44 1500 # 55 56 2500
    
```

Confinement: Tied; #10 ties with #55 bars, #15 with larger bars.
phi(a) = 0.8, phi(s) = 0.85, phi(c) = 0.65, phi(rho) = 1.00, Min. Dimension(h) = 400 mm

Layout: Rectangular
Pattern: Sides Different (Cover to longitudinal reinforcement)
Total steel area: As = 5600 mm^2 at rho = 3.50%
Minimum clear spacing = 67 mm

	Top	Bottom	Left	Right
Bars	4 #30	4 #30	0 #10	0 #10
Cover (mm)	40	40	40	40

Control Points:

```

=====
Bending about Axial Load P X-Moment Y-Moment NA depth Dt depth eps_t
              kN kNm kNm mm mm
-----
X @ Max compression 4705.3 -0.00 0.00 805 345 -0.00200
@ Allowable comp. 3764.2 146.16 0.00 412 345 -0.00057
@ fs = 0.0 3111.1 236.23 0.00 345 345 -0.00000
@ fs = 0.5*fy 2144.0 339.98 0.00 268 345 0.00100
@ Balanced point 1355.5 413.81 0.00 220 345 0.00200
@ Pure bending 0.0 286.39 0.00 79 345 0.01188
@ Max tension -1904.0 -0.00 -0.00 0 345 9.99999
    
```

STRUCTUREPOINT - spColumn v5.50 (TM)
Licensed to: StructurePoint. License ID: 00000-0000000-4-25EF2-2C6B6
C:\TSDA\spColumn\Tied Square Concrete Column CSA.col

Page 3
06/08/17
03:11 PM

-X @ Max compression	4705.3	-0.00	0.00	805	345	-0.00200
@ Allowable comp.	3764.2	-146.16	-0.00	412	345	-0.00057
@ fs = 0.0	3111.1	-236.23	-0.00	345	345	0.00000
@ fs = 0.5*fy	2144.0	-339.98	-0.00	268	345	0.00100
@ Balanced point	1355.5	-413.81	-0.00	220	345	0.00200
@ Pure bending	0.0	-286.39	-0.00	79	345	0.01188
@ Max tension	-1904.0	-0.00	-0.00	0	345	9.99999

*** End of output ***

8. Summary and Comparison of Design Results

Table 1 - Comparison of Results						
Support	P_r , kN			M_r , kN.m		
	Hand	Reference ^{**}	spColumn	Hand	Reference ^{**}	spColumn
Max compression	4705	4490	4705	0	0	0
Allowable compression	3764	3592	3764	---	---	---
$f_s = 0.0$	3111	2945	3111	236	229	236
$f_s = 0.5 f_y$	2144	2015	2144	340	330	340
Balanced point	1355	1253	1355	414	403	414
Pure bending	0	0	0	286	285	286
Max tension	1904	1904	1904	0	0	0
[*] Reinforced Concrete Mechanic and Design, 1 st Canadian Edition, James MacGregor and Fred Bartlett – Example 11-1 ^{**} The reference used CSA A23.3-94 where the resistance factor for concrete (ϕ_c) is 0.60. The hand calculation and spColumn used CSA A23.3-14 where the resistance factor for concrete (ϕ_c) is 0.65. (Check Column Interaction Diagram Using CSA A23.3-94 Example)						

9. Conclusions & Observations

The analysis of the reinforced concrete section performed by [spColumn](#) conforms to the provisions of the Strength Design Method and Unified Design Provisions with all conditions of strength satisfying the applicable conditions of equilibrium and strain compatibility.

In the calculation shown above a P-M interaction diagram was generated with moments about the X-Axis (Uniaxial bending). Since the reinforcement in the section is not symmetrical, a different P-M interaction diagram is needed for the other orthogonal direction about the Y-Axis (See the following Figure for the case where $f_s = f_y$).

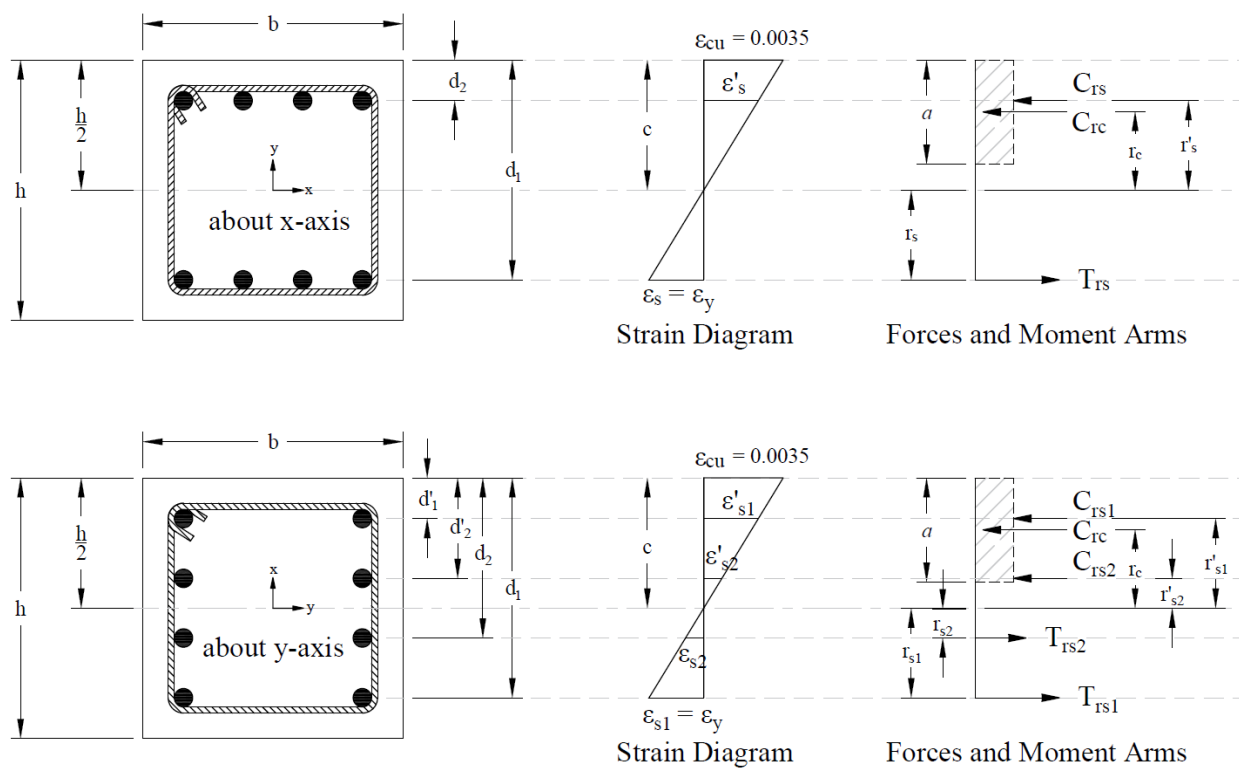

Figure 10 – Strains, Forces, and Moment Arms ($f_s = - f_y$ Moments About x- and y-axis)

When running about the Y-Axis, we have 2 bars in 4 layers instead of 4 bars in just 2 layers (about X-Axis) resulting in a completely different interaction diagram as shown in the following Figure.

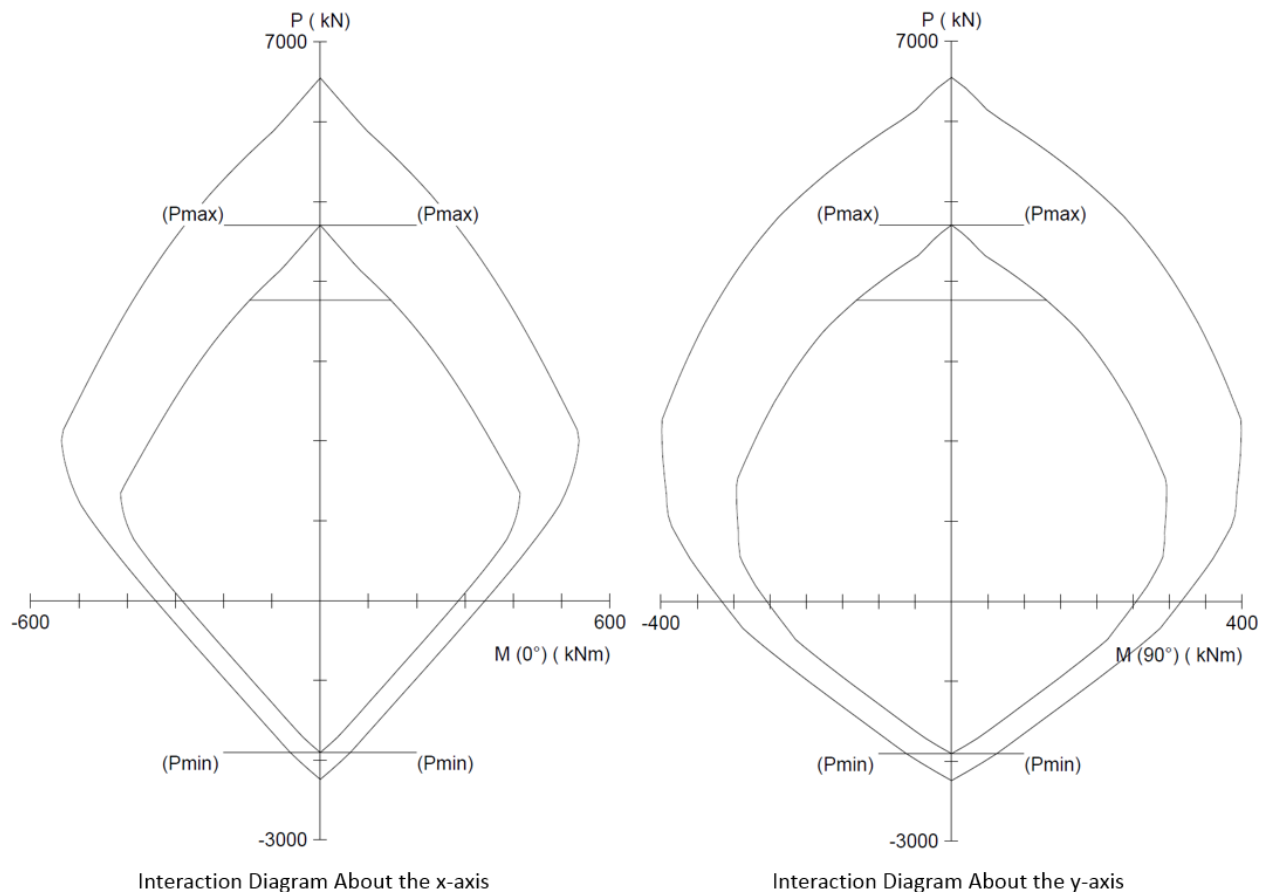

Figure 11 – Comparison of Column Interaction Diagrams about X-Axis and Y-Axis ([spColumn](#))

Further differences in the interaction diagram in both directions can result if the column cross section geometry is irregular.

In most building design calculations, such as the examples shown for [flat plate](#) or [flat slab](#) concrete floor systems, all building columns are subjected to M_x and M_y due to lateral forces and unbalanced moments from both directions of analysis. This requires an evaluation of the column P-M interaction diagram in two directions simultaneously (biaxial bending).

StructurePoint's [spColumn](#) program can also evaluate column sections in biaxial mode to produce the results shown in the following Figure for the column section in this example.

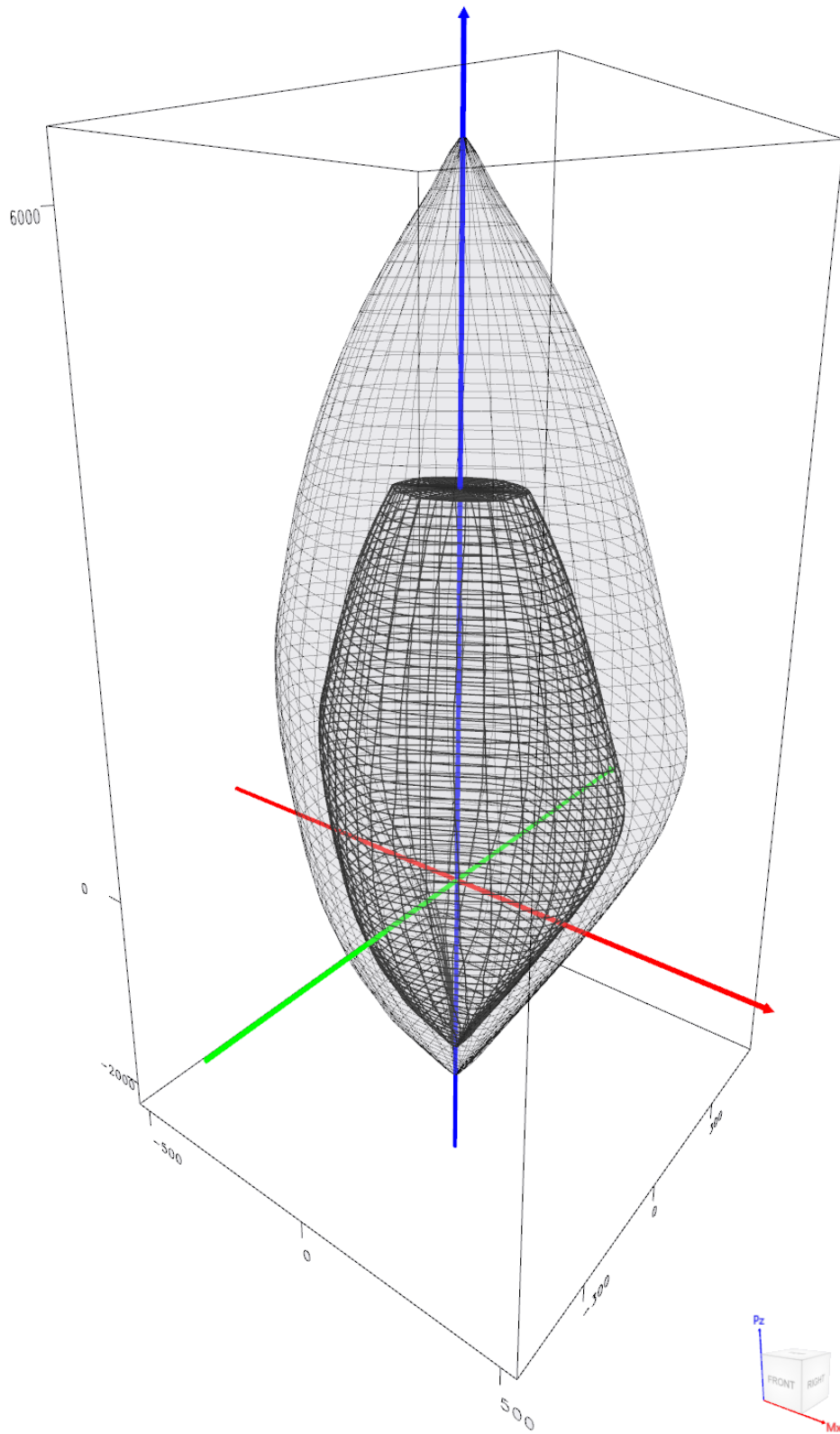

Figure 12 – Nominal & Design Interaction Diagram in Two Directions (Biaxial) (spColumn)