

### Two-Way Flat Plate Concrete Floor System Analysis and Design

The concrete floor slab system shown below is for an intermediate floor to be designed considering partition weight = 20 psf, and unfactored live load = 40 psf. Flat plate concrete floor system does not use beams between columns or drop panels and it is usually suited for lightly loaded floors with short spans typically for residential and hotel buildings. The lateral loads are independently resisted by shear walls. The two design procedures shown in **ACI 318-14**: Direct Design Method (DDM) and the Equivalent Frame Method (EFM) are illustrated in detail in this example. The hand solution from EFM is also used for a detailed comparison with the analysis and design results of the engineering software program [spSlab](#).

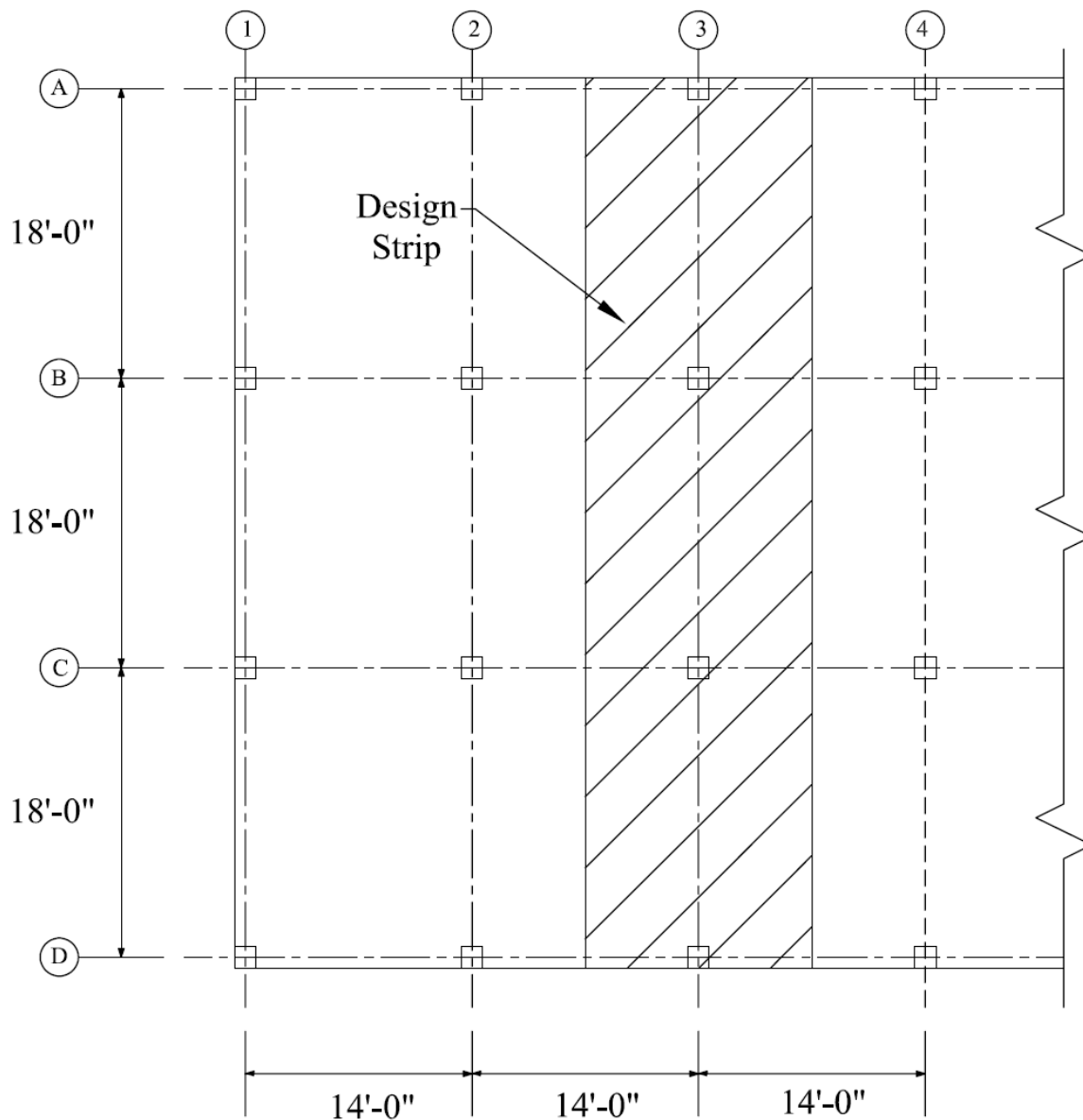

Figure 1 - Two-Way Flat Concrete Floor System

---

## Contents

1. Preliminary Member Sizing .....	1
2. Two-Way Slab Analysis and Design.....	4
2.1. Direct Design Method (DDM) .....	4
2.1.1. Direct design method limitations.....	4
2.1.2. Design moments .....	4
2.1.3. Flexural reinforcement requirements.....	5
2.1.4. Factored moments in columns.....	8
2.2. Equivalent Frame Method (EFM) .....	8
2.2.1. Equivalent frame method limitations .....	9
2.2.2. Frame members of equivalent frame .....	9
2.2.3. Equivalent frame analysis .....	11
2.2.4. Design moments .....	13
2.2.5. Distribution of design moments .....	13
2.2.6. Flexural reinforcement requirements.....	14
2.2.7. Column design moments .....	17
3. Design of Interior, Edge, and Corner Columns .....	19
3.1. Determination of factored loads .....	20
3.2. Column Capacity Diagram (Axial-Moment Interaction Diagram) .....	21
4. Two-Way Slab Shear Strength .....	25
4.1. One-Way (Beam action) Shear Strength .....	25
4.2. Two-Way (Punching) Shear Strength .....	26
5. Two-Way Slab Deflection Control (Serviceability Requirements).....	29
5.1. Immediate (Instantaneous) Deflections.....	30
5.2. Time-Dependent (Long-Term) Deflections ( $\Delta_{lt}$ ).....	39
6. Computer Program Solution.....	40
7. Summary and Comparison of Two-Way Slab Design Results.....	60
8. Comparison of Two-Way Slab Analysis and Design Methods .....	62

## Code

Building Code Requirements for Structural Concrete (ACI 318-14) and Commentary (ACI 318R-14)

Minimum Design Loads for Buildings and Other Structures (ASCE/SEI 7-10)

International Code Council, 2012 International Building Code, Washington, D.C., 2012

## Reference

Notes on ACI 318-11 Building Code Requirements for Structural Concrete, Twelfth Edition, 2013 Portland Cement Association, Example 20.1

Concrete Floor Systems (Guide to Estimating and Economizing), Second Edition, 2002 David A. Fanella

Simplified Design of Reinforced Concrete Buildings, Fourth Edition, 2011 Mahmoud E. Kamara and Lawrence C. Novak

## Design Data

Floor-to-Floor Height = 9 ft (provided by architectural drawings)

Superimposed Dead Load,  $SDL = 20$  psf for framed partitions, wood studs plaster 2 sides

*ASCE/SEI 7-10 (Table C3-1)*

Live Load,  $LL = 40$  psf for Residential floors

*ASCE/SEI 7-10 (Table 4-1)*

$f_c' = 4000$  psi (for slabs)

$f_c' = 6000$  psi (for columns)

$f_y = 60,000$  psi

Required fire resistance rating = 2 hours

## Solution

### 1. Preliminary Member Sizing

#### a. Slab minimum thickness - Deflection

*ACI 318-14 (8.3.1.1)*

In this example deflection will be calculated and checked to satisfy project deflection limits. Minimum member thickness and depths from ACI 318-14 will be used for preliminary sizing.

Using ACI 318-14 minimum slab thickness for two-way construction without interior beams in *Table 8.3.1.1*.

Exterior Panels:  $h = \frac{l_n}{30} = \frac{200}{30} = 6.67$  in.

*ACI 318-14 (Table 8.3.1.1)*

But not less than 5 in.

*ACI 318-14 (8.3.1.1(a))*

Interior Panels:  $h = \frac{l_n}{33} = \frac{200}{33} = 6.06$  in.

*ACI 318-14 (Table 8.3.1.1)*

But not less than 5 in.

*ACI 318-14 (8.3.1.1(a))*

Where  $l_n$  = length of clear span in the long direction =  $216 - 16 = 200$  in.

Try 7 in. slab for all panels (self-weight = 87.5 psf)

b. Slab shear strength – one way shear

Evaluate the average effective depth (Figure 2):

$$d_l = t_{slab} - c_{clear} - d_b - \frac{d_b}{2} = 7 - 0.75 - 0.5 - \frac{0.5}{2} = 5.50 \text{ in.}$$

$$d_t = t_{slab} - c_{clear} - \frac{d_b}{2} = 7 - 0.75 - \frac{0.5}{2} = 6.00 \text{ in.}$$

$$d_{avg} = \frac{d_l + d_t}{2} = \frac{5.50 + 6.00}{2} = 5.75 \text{ in.}$$

Where:

$c_{clear} = 3/4$  in. for # 4 steel bar

ACI 318-14 (Table 20.6.1.3.1)

$d_b = 0.5$  in. for # 4 steel bar

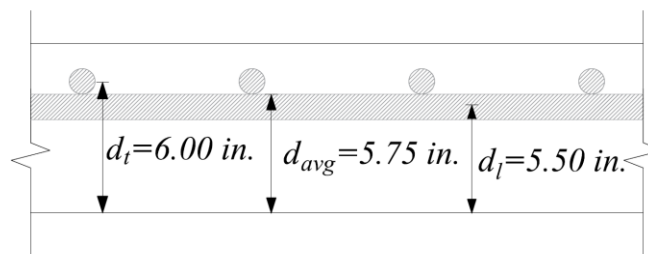

Figure 2 - Two-Way Flat Concrete Floor System

Factored dead load,  $q_{Du} = 1.2 \times (87.5 + 20) = 129$  psf

Factored live load,  $q_{Lu} = 1.6 \times 40 = 64$  psf

ACI 318-14 (5.3.1)

Total factored load  $q_u = 193$  psf

Check the adequacy of slab thickness for beam action (one-way shear)

ACI 318-14 (22.5)

at an interior column:

Consider a 12-in. wide strip. The critical section for one-way shear is located at a distance  $d$ , from the face of support (see Figure 3)

Tributary area for one-way shear is  $A_{Tributary} = \left[ \left( \frac{18}{2} \right) - \left( \frac{16}{2 \times 12} \right) - \left( \frac{5.75}{12} \right) \right] \times \left( \frac{12}{12} \right) = 7.854 \text{ ft}^2$

$V_u = q_u \times A_{Tributary} = 0.193 \times 7.854 = 1.5$  kips

$V_c = 2\lambda\sqrt{f_c}' b_w d$

ACI 318-14 (Eq. 22.5.5.1)

where  $\lambda = 1$  for normal weight concrete

$$\phi V_c = 0.75 \times 2 \times 1.0 \times \sqrt{4000} \times 12 \times \frac{5.75}{1000} = 6.6 \text{ kips} > V_u$$

Slab thickness of 7 in. is adequate for one-way shear.

c. Slab shear strength – two-way shear

Check the adequacy of slab thickness for punching shear (two-way shear) at an interior column (Figure 4):

$$\text{Tributary area for two-way shear is } A_{Tributary} = (18 \times 14) - \left(\frac{16 + 5.75}{12}\right)^2 = 248.7 \text{ ft}^2$$

$$V_u = q_u \times A_{Tributary} = 0.193 \times 248.7 = 48.0 \text{ kips}$$

$$V_c = 4\lambda\sqrt{f_c'}b_o d \quad (\text{For square interior column})$$

ACI 318-14 (Table 22.6.5.2(a))

$$V_c = 4 \times \sqrt{4000} \times (4 \times 21.75) \times \frac{5.75}{1000} = 126.6 \text{ kips}$$

$$\phi V_c = 0.75 \times 126.6 = 95.0 \text{ kips} > V_u$$

Slab thickness of 7 in. is adequate for two-way shear.

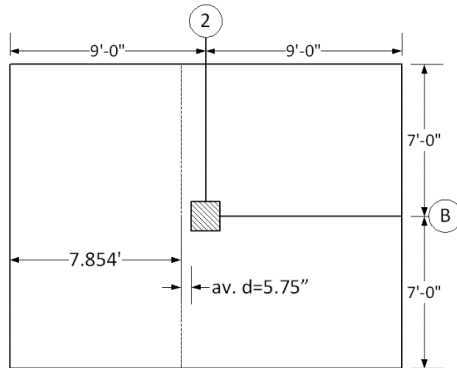

Figure 3 – Critical Section for One-Way

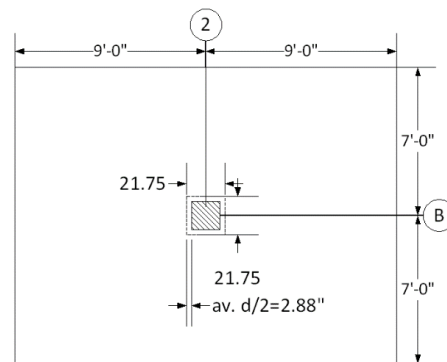

Figure 4 – Critical Section for Two-Way

d. Column dimensions - axial load

Check the adequacy of column dimensions for axial load:

$$\text{Tributary area for interior column is } A_{Tributary} = (18 \times 14) = 252 \text{ ft}^2$$

$$P_u = q_u \times A_{Tributary} = 0.193 \times 252 = 48.6 \text{ kips}$$

$$P_n = 0.80P_o = 0.80 \times (0.85f_c'(A_g - A_{st}) + f_y A_{st}) \quad (\text{For square interior column}) \quad \text{ACI 318-14 (22.4.2)}$$

$$P_n = 0.80 \times (0.85(6000)(16 \times 16 - 0) + 0) = 1,044,480 \text{ lb} = 1,044 \text{ kips}$$

$$\phi P_n = 0.65 \times 1,044 = 679 \text{ kips} > P_u = 48.6 \text{ kips}$$

Column dimensions of 16 in. x 16 in. are adequate for axial load.

## 2. Two-Way Slab Analysis and Design

ACI 318 states that a slab system shall be designed by any procedure satisfying equilibrium and geometric compatibility, provided that strength and serviceability criteria are satisfied. Distinction of two-systems from one-way systems is given by ACI 318-14 (R8.10.2.3 & R8.3.1.2).

ACI 318 permits the use of Direct Design Method (DDM) and Equivalent Frame Method (EFM) for the gravity load analysis of orthogonal frames and is applicable to flat plates, flat slabs, and slabs with beams. The following sections outline the solution per DDM, EFM, and spSlab software respectively.

### 2.1. Direct Design Method (DDM)

Two-way slabs satisfying the limits in ACI 318-14 (8.10.2) are permitted to be designed in accordance with the DDM.

#### 2.1.1. Direct design method limitations

There is a minimum of three continuous spans in each direction ACI 318-14 (8.10.2.1)

Successive span lengths are equal ACI 318-14 (8.10.2.2)

Long-to-short span ratio is  $1.29 < 2$  ACI 318-14 (8.10.2.3)

Columns are not offset ACI 318-14 (8.10.2.4)

Loads are uniformly distributed over the entire panel ACI 318-14 (8.10.2.5)

Service live-to-dead load ratio of  $0.37 < 2.0$  ACI 318-14 (8.10.2.6)

Slab system is without beams and this requirement is not applicable ACI 318-14 (8.10.2.7)

Since all the criteria are met, Direct Design Method can be utilized.

#### 2.1.2. Design moments

a. Calculate the total factored static moment:

$$M_o = \frac{q_u \ell_2 \ell_n^2}{8} = \frac{0.193 \times 14 \times 16.67^2}{8} = 93.6 \text{ ft-kips} \quad \text{ACI 318-14 (8.10.3.2)}$$

b. Distribute the total factored moment,  $M_o$ , in an interior and end span: ACI 318-14 (8.10.4)

Table 1 - Distribution of $M_o$ along the span		
Location		Total Design Strip Moment, $M_{DS}$ (ft-kips)
Exterior Span	Exterior Negative	$0.26 \times M_o = 24.3$
	Positive	$0.52 \times M_o = 48.7$
	Interior Negative	$0.70 \times M_o = 65.5$
Interior Span	Positive	$0.35 \times M_o = 32.8$

- c. Calculate the column strip moments.

ACI 318-14 (8.10.5)

That portion of negative and positive total design strip moments not resisted by column strips shall be proportionally assigned to corresponding two half-middle strips.

ACI 318-14 (8.10.6.1)

Location		Total Design Strip Moment, $M_{DS}$ (ft-kips)	Column Strip Moment, (ft-kips)	Moment in Two Half Middle Strips, (ft-kips)
Exterior Span	Exterior Negative*	24.3	$1.00 \times M_{DS} = 24.3$	$0.00 \times M_{DS} = 0.0$
	Positive	48.7	$0.60 \times M_{DS} = 29.2$	$0.40 \times M_{DS} = 19.5$
	Interior Negative*	65.5	$0.75 \times M_{DS} = 49.1$	$0.25 \times M_{DS} = 16.4$
Interior Span	Positive	32.8	$0.60 \times M_{DS} = 19.7$	$0.40 \times M_{DS} = 13.1$

\* All negative moments are at face of support.

### 2.1.3. Flexural reinforcement requirements

- a. Determine flexural reinforcement required for column and middle strips at all critical sections

The following calculation is for the exterior span exterior negative location of the column strip.

$$M_u = 24.3 \text{ ft-kips}$$

Use average  $d_{avg} = 5.75$  in.

To determine the area of steel, assumptions have to be made whether the section is tension or compression controlled, and regarding the distance between the resultant compression and tension forces along the slab section ( $jd$ ). In this example, tension-controlled section will be assumed so the reduction factor  $\phi$  is equal to 0.9, and  $jd$  will be taken equal to  $0.95d$ . The assumptions will be verified once the area of steel is finalized.

$$\text{Assume } jd = 0.95 \times d = 5.46 \text{ in.}$$

$$\text{Column strip width, } b = (14 \times 12) / 2 = 84 \text{ in.}$$

$$\text{Middle strip width, } b = 14 \times 12 - 84 = 84 \text{ in.}$$

$$A_s = \frac{M_u}{\phi f_y jd} = \frac{24.3 \times 12000}{0.9 \times 60000 \times 0.95 \times 5.75} = 0.99 \text{ in}^2$$

Recalculate 'a' for the actual  $A_s = 0.99 \text{ in}^2$ :

$$a = \frac{A_s f_y}{0.85 f'_c b} = \frac{0.99 \times 60000}{0.85 \times 4000 \times 84} = 0.208 \text{ in}$$

$$c = \frac{a}{\beta_1} = \frac{0.208}{0.85} = 0.244 \text{ in}$$

$$\epsilon_t = \left(\frac{0.003}{c}\right)d_t - 0.003 = \left(\frac{0.003}{0.244}\right) \times 5.75 - 0.003 = 0.0676 > 0.005$$

Therefore, the assumption that section is tension-controlled is valid.

$$A_s = \frac{M_u}{\phi f_y (d - a/2)} = \frac{24.3 \times 12000}{0.9 \times 60000 \times (5.75 - 0.208/2)} = 0.96 \text{ in}^2$$

$$\text{Min } A_s = 0.018 \times 84 \times 7 = 1.06 \text{ in}^2 > 0.96 \text{ in}^2 \quad \text{ACI 318-14 (24.4.3.2)}$$

$$\text{Maximum spacing } s_{\max} = 2h = 2 \times 7 = 14 \text{ in} < 18 \text{ in} \quad \text{ACI 318-14 (8.7.2.2)}$$

Provide 6 - #4 bars with  $A_s = 1.20 \text{ in}^2$  and  $s = 84/6 = 14 \text{ in} \leq s_{\max}$

Based on the procedure outlined above, values for all span locations are given in Table 3.

Table 3 - Required Slab Reinforcement for Flexure (DDM)								
Span Location		$M_u$ (ft-kips)	b (in.)	d (in.)	$A_s$ Req'd for flexure (in <sup>2</sup> )	Min $A_s$ (in <sup>2</sup> )	Reinforcement Provided	$A_s$ Prov. for flexure (in <sup>2</sup> )
<b>End Span</b>								
Column Strip	Exterior Negative	24.3	84	5.75	0.96	1.06	6-#4	1.2
	Positive	29	84	5.75	1.15	1.06	6-#4	1.2
	Interior Negative	49.6	84	5.75	1.99	1.06	10-#4	2
Middle Strip	Exterior Negative	0	84	5.75	0	1.06	6-#4	1.2
	Positive	19.7	84	5.75	0.77	1.06	6-#4	1.2
	Interior Negative	15.9	84	5.75	0.62	1.06	6-#4	1.2
<b>Interior Span</b>								
Column Strip	Positive	19.7	84	5.75	0.77	1.06	6-#4	1.2
Middle Strip	Positive	13.1	84	5.75	0.51	1.06	6-#4	1.2

- b. Calculate additional slab reinforcement at columns for moment transfer between slab and column

The factored slab moment resisted by the column ( $\gamma_f \times M_u$ ) shall be assumed to be transferred by flexure. Concentration of reinforcement over the column by closer spacing or additional reinforcement shall be used to resist this moment. The fraction of slab moment not calculated to be resisted by flexure shall be assumed to be resisted by eccentricity of shear. ACI 318-14 (8.4.2.3)

Portion of the unbalanced moment transferred by flexure is  $\gamma_f \times M_u$  ACI 318-14 (8.4.2.3.1)



Where

$$\gamma_f = \frac{1}{1 + (2/3) \times \sqrt{b_1/b_2}} \quad \text{ACI 318-14 (8.4.2.3.2)}$$

$b_1$  = Dimension of the critical section  $b_o$  measured in the direction of the span for which moments are determined in ACI 318, Chapter 8 (see Figure 5).

$b_2$  = Dimension of the critical section  $b_o$  measured in the direction perpendicular to  $b_1$  in ACI 318, Chapter 8 (see Figure 5).

$$b_b = \text{Effective slab width} = c_2 + 3 \times h \quad \text{ACI 318-14 (8.4.2.3.3)}$$

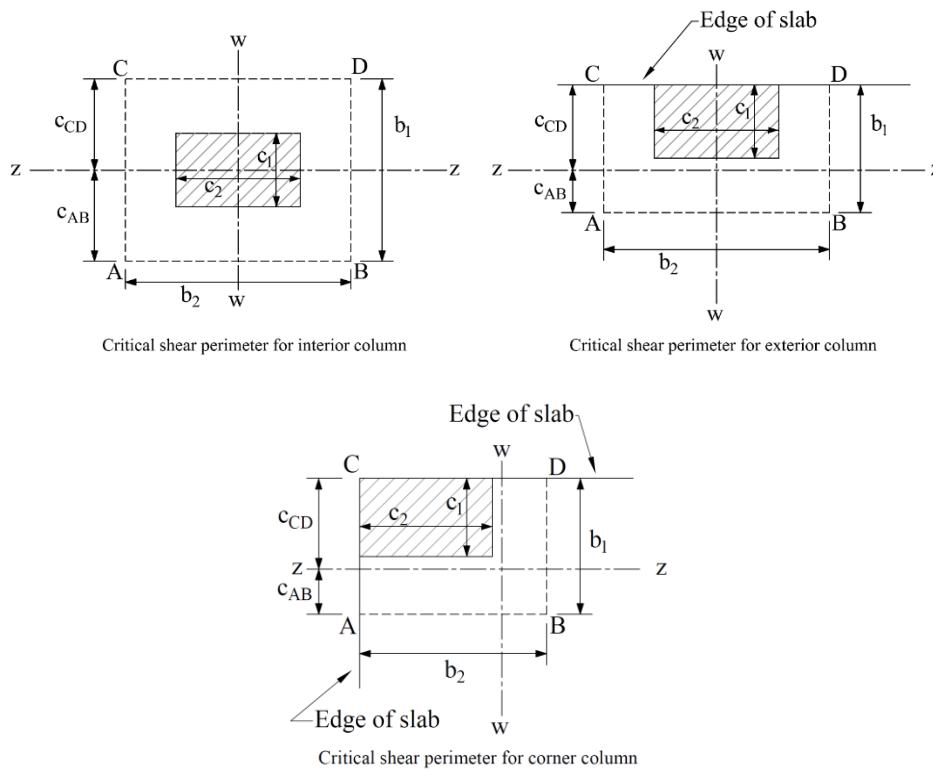

**Figure 5 – Critical Shear Perimeters for Columns**

Table 4 - Additional Slab Reinforcement required for moment transfer between slab and column (DDM)									
Span Location		$M_u^*$ (ft-kips)	$\gamma_r$	$\gamma_r M_u$ (ft-kips)	Effective slab width, $b_b$ (in.)	$d$ (in.)	$A_s$ req'd within $b_b$ (in <sup>2</sup> )	$A_s$ prov. For flexure within $b_b$ (in <sup>2</sup> )	Add'l Reinf.
<b>End Span</b>									
Column Strip	Exterior Negative	24.3	0.62	15.1	37	5.75	0.6	0.53	1-#4
	Interior Negative	0.0	0.60	0.0	37	5.75	0.0	0.97	-

\* $M_u$  is taken at the centerline of the support in Equivalent Frame Method solution.

### 2.1.4. Factored moments in columns

a. Interior columns:

$$M_u = 0.07 \times [(q_{Du} + 0.5 \times q_{Lu}) \times \ell_2 \times \ell_n^2 - q_{Du} \times \ell_2 \times (\ell_n')^2] \quad \text{ACI 318-14 (8.10.7.2)}$$

$$M_u = 0.07 \times \left( (129 + 0.5 \times 64) \times 14 \times \left( 18 - \frac{16}{12} \right)^2 - 129 \times 18 \times \left( 14 - \frac{16}{12} \right)^2 \right) = 17.75 \text{ ft-kips}$$

With the same column size and length above and below the slab,

$$M_{column} = \frac{17.75}{2} = 8.87 \text{ ft-kips}$$

b. Exterior Columns:

Total exterior negative moment from slab must be transferred directly to the column:  $M_u = 24.3$  ft-kips. With the same column size and length above and below the slab,

$$M_{column} = \frac{24.3}{2} = 12.15 \text{ ft-kips}$$

The moments determined above are combined with the factored axial loads (for each story) for design of column sections as shown later in this example.

## 2.2. Equivalent Frame Method (EFM)

EFM is the most comprehensive and detailed procedure provided by the ACI 318 for the analysis and design of two-way slab systems where the structure is modeled by a series of equivalent frames (interior and exterior) on column lines taken longitudinally and transversely through the building.

The equivalent frame consists of three parts:

- 1) Horizontal slab-beam strip, including any beams spanning in the direction of the frame. Different values of moment of inertia along the axis of slab-beams should be taken into account where the gross moment of inertia at any cross section outside of joints or column capitals shall be taken, and the moment of inertia of the slab-beam at the face of the column, bracket or capital divide by the quantity  $(1-c_2/l_2)^2$  shall be assumed for the calculation of the moment of inertia of slab-beams from the center of the column to the face of the column, bracket or capital. ACI 318-14 (8.11.3)
- 2) Columns or other vertical supporting members, extending above and below the slab. Different values of moment of inertia along the axis of columns should be taken into account where the moment of inertia of columns from top and bottom of the slab-beam at a joint shall be assumed to be infinite, and the gross cross section of the concrete is permitted to be used to determine the moment of inertia of columns at any cross section outside of joints or column capitals. ACI 318-14 (8.11.4)
- 3) Elements of the structure (Torsional members) that provide moment transfer between the horizontal and vertical members. These elements shall be assumed to have a constant cross section throughout their

length consisting of the greatest of the following: (1) portion of slab having a width equal to that of the column, bracket, or capital in the direction of the span for which moments are being determined, (2) portion of slab specified in (1) plus that part of the transverse beam above and below the slab for monolithic or fully composite construction, (3) the transverse beam includes that portion of slab on each side of the beam extending a distance equal to the projection of the beam above or below the slab, whichever is greater, but not greater than four times the slab thickness. ACI 318-14 (8.11.5)

### 2.2.1. Equivalent frame method limitations

In EFM, live load shall be arranged in accordance with 6.4.3 which requires slab systems to be analyzed and designed for the most demanding set of forces established by investigating the effects of live load placed in various critical patterns. ACI 318-14 (8.11.1.2 & 6.4.3)

Complete analysis must include representative interior and exterior equivalent frames in both the longitudinal and transverse directions of the floor ACI 318-14 (8.11.2.1)

Panels shall be rectangular, with a ratio of longer to shorter panel dimensions, measured center-to-center of supports, not to exceed 2. ACI 318-14 (8.10.2.3)

### 2.2.2. Frame members of equivalent frame

Determine moment distribution factors and fixed-end moments for the equivalent frame members. The moment distribution procedure will be used to analyze the equivalent frame. Stiffness factors  $k$ , carry over factors COF, and fixed-end moment factors FEM for the slab-beams and column members are determined using the design aids tables at Appendix 20A of PCA Notes on ACI 318-11. These calculations are shown below.

- a. Flexural stiffness of slab-beams at both ends,  $K_{sb}$ .

$$\frac{c_{N1}}{\ell_1} = \frac{16}{(18 \times 12)} = 0.07, \quad \frac{c_{N2}}{\ell_2} = \frac{16}{(14 \times 12)} = 0.1$$

For  $c_{F1} = c_{F2}$ , stiffness factors,  $k_{NF} = k_{FN} = 4.13$

PCA Notes on ACI 318-11 (Table A1)

$$\text{Thus, } K_{sb} = k_{NF} \frac{E_{cs} I_s}{\ell_1} = 4.13 \frac{E_{cs} I_s}{\ell_1}$$

PCA Notes on ACI 318-11 (Table A1)

$$K_{sb} = 4.13 \times 3834 \times 10^3 \times \frac{4802}{216} = 352 \times 10^6 \text{ in.-lb}$$

$$\text{where, } I_s = \frac{\ell_s h^3}{12} = \frac{168 \times (7)^3}{12} = 4802 \text{ in}^4$$

$$E_{cs} = w_c^{1.5} 33 \sqrt{f'_c} = 150^{1.5} \times 33 \times \sqrt{4000} = 3834 \times 10^3 \text{ psi}$$

ACI 318-14 (19.2.2.1.a)

Carry-over factor COF = 0.509

PCA Notes on ACI 318-11 (Table A1)

Fixed-end moment FEM =  $0.0843w_u \ell_2 \ell_1^2$

PCA Notes on ACI 318-11 (Table A1)

b. Flexural stiffness of column members at both ends,  $K_c$ .

Referring to Table A7, Appendix 20A,  $t_a = 3.5$  in.,  $t_b = 3.5$  in.,

$$H = 9 \text{ ft} = 108 \text{ in.}, H_c = 101 \text{ in.}, \frac{t_a}{t_b} = 1, \frac{H}{H_c} = 1.07$$

Thus,  $k_{AB} = k_{BA} = 4.74$  by interpolation.

$$K_c = \frac{4.74 E_{cc} I_c}{\ell_c}$$

PCA Notes on ACI 318-11 (Table A7)

$$K_c = 4.74 \times 4696 \times 10^3 \times \frac{5461}{108} = 1125.5 \times 10^6 \text{ in.-lb}$$

$$\text{Where } I_c = \frac{c^4}{12} = \frac{(16)^4}{12} = 5461 \text{ in.}^4$$

$$E_{cc} = w_c^{1.5} 33 \sqrt{f'_c} = 150^{1.5} \times 33 \times \sqrt{6000} = 4696 \times 10^3 \text{ psi}$$

ACI 318-14 (19.2.2.1.a)

$$\ell_c = 9 \text{ ft} = 108 \text{ in.}$$

c. Torsional stiffness of torsional members,  $K_t$ .

$$K_t = \frac{9 E_{cs} C}{[\ell_2 (1 - \frac{c_2}{\ell_2})^3]}$$

ACI 318-14 (R.8.11.5)

$$K_t = \frac{9 \times 3834 \times 10^3 \times 1325}{168(0.905)^3} = 367 \times 10^6 \text{ in.-lb}$$

$$\text{Where } C = \sum (1 - 0.63 \frac{x}{y}) (\frac{x^3 y}{3})$$

ACI 318-14 (Eq. 8.10.5.2b)

$$C = (1 - 0.63 \times \frac{7}{16}) (7^3 \times \frac{16}{3}) = 1325 \text{ in.}^4$$

$$c_2 = 16 \text{ in.}, \text{ and } \ell_2 = 14 \text{ ft} = 168 \text{ in.}$$

d. Equivalent column stiffness  $K_{ec}$ .

$$K_{ec} = \frac{\sum K_c \times \sum K_t}{\sum K_c + \sum K_t}$$

$$K_{ec} = \frac{(2 \times 1125.5)(2 \times 367)}{[(2 \times 1125.5) + (2 \times 367)]} \times 10^6$$

$$K_{ec} = 553.7 \times 10^6 \text{ in.-lb}$$

Where  $\sum K_t$  is for two torsional members one on each side of the column, and  $\sum K_c$  is for the upper and lower columns at the slab-beam joint of an intermediate floor.

e. Slab-beam joint distribution factors,  $DF$ .

At exterior joint,

$$DF = \frac{352}{(352 + 553.7)} = 0.389$$

At interior joint,

$$DF = \frac{352}{(352 + 352 + 553.7)} = 0.280$$

COF for slab-beam = 0.509

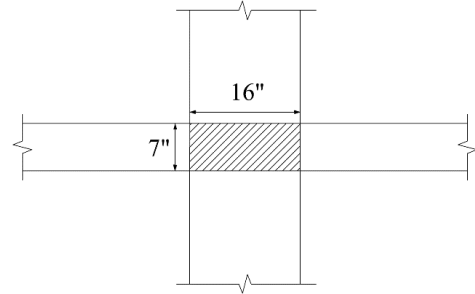

Figure 6 - Torsional Member

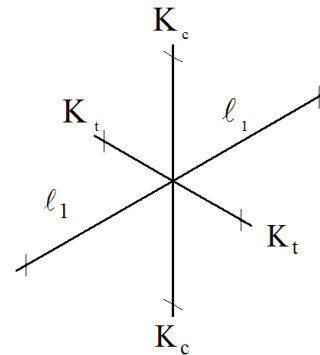
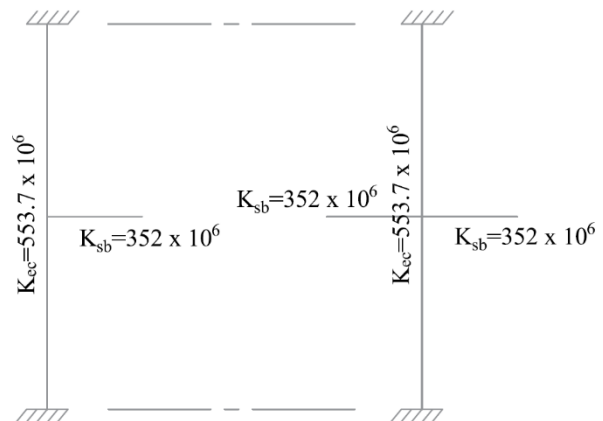

Figure 7 - Column and Edge of Slab



EXTERIOR COLUMN                      INTERIOR COLUMN

Figure 8 - Slab and Column Stiffness

### 2.2.3. Equivalent frame analysis

Determine negative and positive moments for the slab-beams using the moment distribution method. Since the unfactored live load does not exceed three-quarters of the unfactored dead load, design moments are assumed to occur at all critical sections with full factored live on all spans. **ACI 318-14 (6.4.3.2)**

$$\frac{L}{D} = \frac{40}{(87.5 + 20)} = 0.37 < \frac{3}{4}$$

a. Factored load and Fixed-End Moments (FEM's).

Factored dead load  $q_{Du} = 1.2(87.5 + 20) = 129$  psf

Factored live load  $q_{Lu} = 1.6(40) = 64$  psf

Factored load  $q_u = q_{Du} + q_{Lu} = 193$  psf

FEM's for slab-beams  $= m_{NF} q_u \ell_2 \ell_1^2$

PCA Notes on ACI 318-11 (Table A1)

$= 0.0841 (0.193 \times 14) 18^2 = 73.8$  ft-kips

- b. Moment distribution. Computations are shown in Table 5. Counterclockwise rotational moments acting on the member ends are taken as positive. Positive span moments are determined from the following equation:

$$M_u (\text{midspan}) = M_o - \frac{(M_{uL} + M_{uR})}{2}$$

Where  $M_o$  is the moment at the midspan for a simple beam.

When the end moments are not equal, the maximum moment in the span does not occur at the midspan, but its value is close to that midspan for this example.

Positive moment in span 1-2:

$$+ M_u = (0.193 \times 14) \frac{18^2}{8} - \frac{(46.6 + 84.0)}{2} = 44.1 \text{ ft-kips}$$

Positive moment span 2-3:

$$+ M_u = (0.193 \times 14) \frac{18^2}{8} - \frac{(76.2 + 76.2)}{2} = 33.2 \text{ ft-kips}$$

**Table 5 – Moment Distribution for Equivalent Frame**

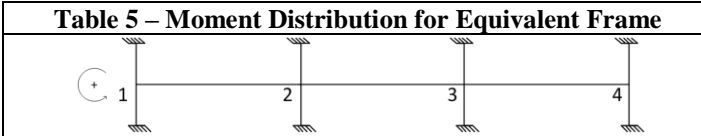

Joint	1	2		3		4
Member	1-2	2-1	2-3	3-2	3-4	4-3
DF	0.389	0.280	0.280	0.280	0.280	0.389
COF	0.509	0.509	0.509	0.509	0.509	0.509
FEM	+73.8	-73.8	+73.8	-73.8	+73.8	-73.8
Dist	-28.7	0.0	0.0	0.0	0.0	28.7
CO	0.0	-14.6	0.0	0.0	14.6	0.0
Dist	0.0	4.1	4.1	-4.1	-4.1	0.0
CO	2.1	0.0	-2.1	2.1	0.0	-2.1
Dist	-0.8	0.6	0.6	-0.6	-0.6	0.8
CO	0.3	-0.4	-0.3	0.3	0.4	-0.3
Dist	-0.1	0.2	0.2	-0.2	-0.2	0.1
CO	0.1	-0.1	-0.1	0.1	0.1	-0.1
Dist	0.0	0.0	0.0	0.0	0.0	0.0
Neg. M	46.6	-84.0	76.2	-76.2	84.0	-46.6
M at midspan	44.1		33.2		44.1	

### 2.2.4. Design moments

Positive and negative factored moments for the slab system in the direction of analysis are plotted in Figure 9. The negative moments used for design are taken at the faces of supports (rectangle section or equivalent rectangle for circular or polygon sections) but not at distances greater than  $0.175\ell_1$  from the centers of supports. ACI 318-14 (8.11.6.1)

$$\frac{16 \text{ in.}}{12 \times 2} = 0.67 \text{ ft} < 0.175 \times 18 = 3.2 \text{ ft (use face of support location)}$$

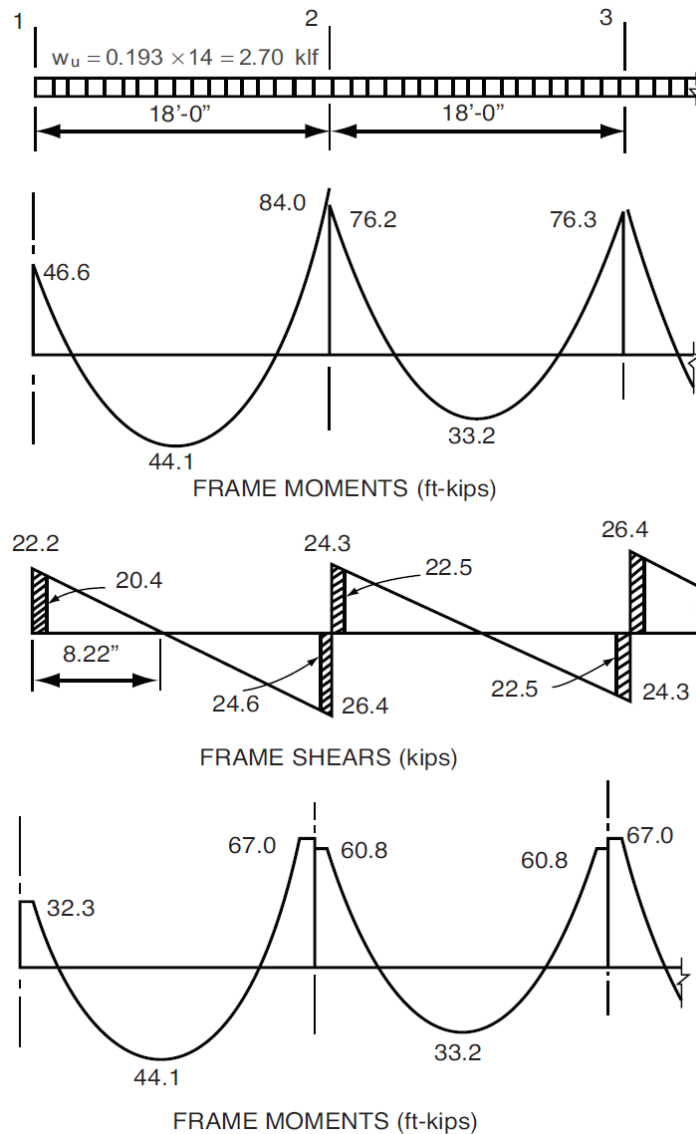

Figure 9 - Positive and Negative Design Moments for Slab-Beam (All Spans Loaded with Full Factored Live Load)

### 2.2.5. Distribution of design moments

- a. Check whether the moments calculated above can take advantage of the reduction permitted by ACI 318-14 (8.11.6.5):

If the slab system analyzed using EFM within the limitations of ACI 318-14 (8.10.2), it is permitted by the ACI code to reduce the calculated moments obtained from EFM in such proportion that the absolute sum of the positive and average negative design moments need not exceed the value obtained from the following equation:

$$M_o = \frac{q_u \ell_2 \ell_n^2}{8} = 0.193 \times 14 \times \frac{(16.67)^2}{8} = 93.9 \text{ ft-kips} \quad \text{ACI 318-14 (Eq. 8.10.3.2)}$$

$$\text{End spans: } 44.1 + \frac{(32.3 + 67.0)}{2} = 93.8 \text{ ft-kips}$$

$$\text{Interior span: } 33.2 + \frac{(60.8 + 60.8)}{2} = 94 \text{ ft-kips}$$

The total design moments from the Equivalent Frame Method yield a static moment equal to that given by the Direct Design Method and no appreciable reduction can be realized.

b. Distribute factored moments to column and middle strips:

After the negative and positive moments have been determined for the slab-beam strip, the ACI code permits the distribution of the moments at critical sections to the column strips, beams (if any), and middle strips in accordance with the DDM.

ACI 318-14 (8.11.6.6)

Distribution of factored moments at critical sections is summarized in Table 6.

<b>Table 6 - Distribution of factored moments</b>						
		Slab-beam Strip	Column Strip		Middle Strip	
		Moment (ft-kips)	Percent	Moment (ft-kips)	Percent	Moment (ft-kips)
End Span	Exterior Negative	32.3	100	32.3	0	0
	Positive	44.1	60	26.5	40	17.7
	Interior Negative	67	75	50.3	25	16.7
Interior Span	Negative	60.8	75	45.6	25	15.2
	Positive	33.2	60	19.9	40	13.2

### 2.2.6. Flexural reinforcement requirements

a. Determine flexural reinforcement required for strip moments

The flexural reinforcement calculation for the column strip of end span – exterior negative location is provided below.

$$M_u = 32.3 \text{ ft-kips}$$

Use average  $d_{avg} = 5.75 \text{ in.}$



To determine the area of steel, assumptions have to be made whether the section is tension or compression controlled, and regarding the distance between the resultant compression and tension forces along the slab section ( $jd$ ). In this example, tension-controlled section will be assumed so the reduction factor  $\phi$  is equal to 0.9, and  $jd$  will be taken equal to  $0.95d$ . The assumptions will be verified once the area of steel is finalized.

Assume  $jd = 0.95 \times d = 5.46$  in.

Column strip width,  $b = (14 \times 12) / 2 = 84$  in.

Middle strip width,  $b = 14 \times 12 - 84 = 84$  in.

$$A_s = \frac{M_u}{\phi f_y jd} = \frac{32.3 \times 12000}{0.9 \times 60000 \times 0.95 \times 5.75} = 1.31 \text{ in.}^2$$

Recalculate 'a' for the actual  $A_s = 1.31 \text{ in.}^2$ :  $a = \frac{A_s f_y}{0.85 f'_c b} = \frac{1.31 \times 60000}{0.85 \times 4000 \times 84} = 0.276$  in.

$$c = \frac{a}{\beta_1} = \frac{0.276}{0.85} = 0.325 \text{ in.}$$

$$\epsilon_t = \left( \frac{0.003}{c} \right) d_t - 0.003 = \left( \frac{0.003}{0.325} \right) \times 5.75 - 0.003 = 0.0501 > 0.005$$

Therefore, the assumption that section is tension-controlled is valid.

$$A_s = \frac{M_u}{\phi f_y (d - a/2)} = \frac{32.3 \times 12000}{0.9 \times 60000 \times (5.75 - 0.276/2)} = 1.28 \text{ in.}^2$$

$$\text{Min } A_s = 0.018 \times 84 \times 7 = 1.06 \text{ in.}^2 < 1.28 \text{ in.}^2$$

**ACI 318-14 (24.4.3.2)**

$$\text{Maximum spacing } s_{\text{max}} = 2h = 2 \times 7 = 14 \text{ in.} < 18 \text{ in.}$$

**ACI 318-14 (8.7.2.2)**

Provide 7 - #4 bars with  $A_s = 1.40 \text{ in.}^2$  and  $s = 84/7 = 12 \text{ in.} \leq s_{\text{max}}$

Based on the procedure outlined above, values for all span locations are given in Table 7.

Table 7 - Required Slab Reinforcement for Flexure [Equivalent Frame Method (EFM)]								
Span Location		M <sub>u</sub> (ft-kips)	b * (in.)	d ** (in.)	A <sub>s</sub> Req'd for flexure (in <sup>2</sup> )	Min A <sub>s</sub> <sup>†</sup> (in <sup>2</sup> )	Reinforcement Provided‡	A <sub>s</sub> Prov. for flexure (in <sup>2</sup> )
<b>End Span</b>								
Column Strip	Exterior Negative	32.3	84	5.75	1.28	1.06	7-#4	1.4
	Positive	26.5	84	5.75	1.04	1.06	6-#4	1.2
	Interior Negative	50.3	84	5.75	2.02	1.06	11-#4	2.2
Middle Strip	Exterior Negative	0	84	5.75	0	1.06	6-#4	1.2
	Positive	17.7	84	5.75	0.69	1.06	6-#4	1.2
	Interior Negative	16.7	84	5.75	0.65	1.06	6-#4	1.2
<b>Interior Span</b>								
Column Strip	Positive	19.9	84	5.75	0.78	1.06	6-#4	1.2
Middle Strip	Positive	13.2	84	5.75	0.51	1.06	6-#4	1.2

- b. Calculate additional slab reinforcement at columns for moment transfer between slab and column by flexure

The factored slab moment resisted by the column ( $\gamma_f \times M_u$ ) shall be assumed to be transferred by flexure.

Concentration of reinforcement over the column by closer spacing or additional reinforcement shall be used to resist this moment. The fraction of slab moment not calculated to be resisted by flexure shall be assumed to be resisted by eccentricity of shear. ACI 318-14 (8.4.2.3)

Portion of the unbalanced moment transferred by flexure is  $\gamma_f \times M_u$  ACI 318-14 (8.4.2.3.1)

Where

$$\gamma_f = \frac{1}{1 + (2/3) \times \sqrt{b_1/b_2}} \quad \text{ACI 318-14 (8.4.2.3.2)}$$

$b_1$  = Dimension of the critical section  $b_o$  measured in the direction of the span for which moments are determined in ACI 318, Chapter 8 (see Figure 5).

$b_2$  = Dimension of the critical section  $b_o$  measured in the direction perpendicular to  $b_1$  in ACI 318, Chapter 8 (see Figure 5).

$b_b$  = Effective slab width =  $c_2 + 3 \times h$  ACI 318-14 (8.4.2.3.3)

Table 8 - Additional Slab Reinforcement required for moment transfer between slab and column (EFM)									
Span Location		$M_u^*$ (ft-kips)	$\gamma_f$	$\gamma_f M_u$ (ft-kips)	Effective slab width, $b_b$ (in.)	$d$ (in.)	$A_s$ req'd within $b_b$ (in <sup>2</sup> )	$A_s$ prov. For flexure within $b_b$ (in <sup>2</sup> )	Add'l Reinf.
<b>End Span</b>									
Column Strip	Exterior Negative	46.6	0.60	28.9	37	5.75	1.17	0.62	3-#4
	Interior Negative	7.8	0.60	4.7	37	5.75	0.18	0.97	-

\* $M_u$  is taken at the centerline of the support in Equivalent Frame Method solution.

### 2.2.7. Column design moments

The unbalanced moment from the slab-beams at the supports of the equivalent frame are distributed to the support columns above and below the slab-beam in proportion to the relative stiffness of the support columns. Referring to Figure 9, the unbalanced moment at joints 1 and 2 are:

$$\text{Joint 1} = +46.6 \text{ ft-kips}$$

$$\text{Joint 2} = -84.0 + 76.2 = -7.8 \text{ ft-kips}$$

The stiffness and carry-over factors of the actual columns and the distribution of the unbalanced slab moments ( $M_{sc}$ ) to the exterior and interior columns are shown in Figure 10a.

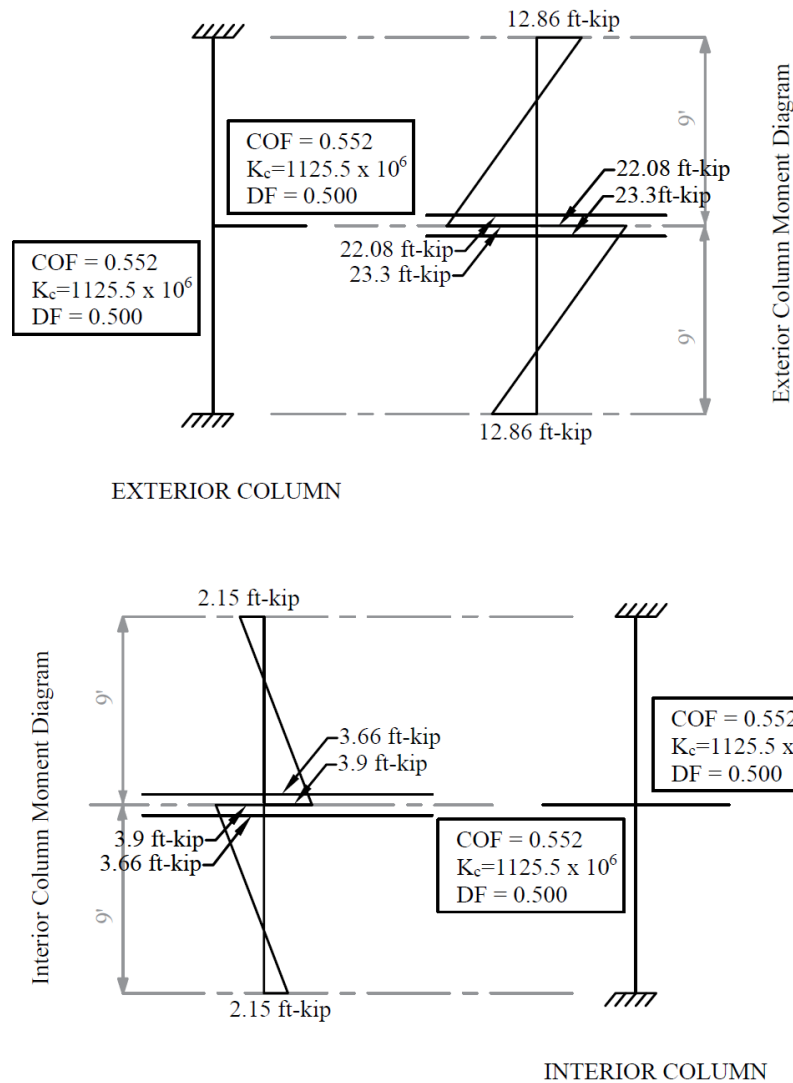

Figure 10a - Column Moments (Unbalanced Moments from Slab-Beam)

In summary:

$$M_{col,Exterior} = 22.08 \text{ ft-kips}$$

$$M_{col,Interior} = 3.66 \text{ ft-kips}$$

The moments determined above are combined with the factored axial loads (for each story) and factored moments in the transverse direction for design of column sections. Figure 10b shows the moment diagrams in the longitudinal and transverse direction for the interior and exterior equivalent frames. Following the previous procedure, the moment values at the face of interior, exterior, and corner columns from the unbalanced moment values can be obtained. These values are shown in the following table.

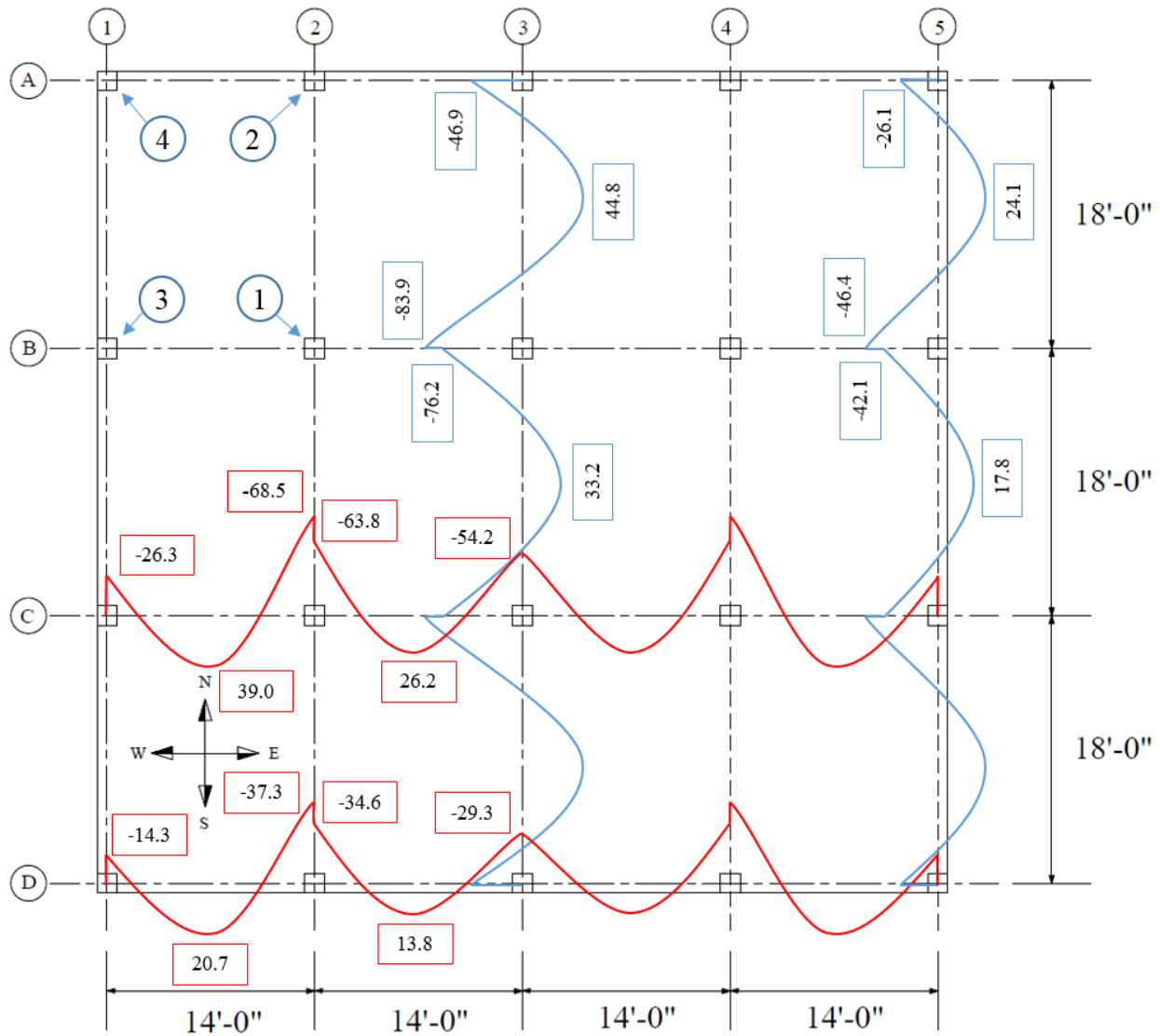

Figure 10b – Moment Diagrams (kips-ft)

$M_u$ kips-ft	Column number (See Figure 10b)			
	1	2	3	4
$M_{ux}$	3.66	22.08	2.04	12.39
$M_{uy}$	2.23	1.28	12.49	6.79

### 3. Design of Interior, Edge, and Corner Columns

This section includes the design of interior, edge, and corner columns using spColumn software. The preliminary dimensions for these columns were calculated previously in section one. The reduction of live load per ASCE 7-10 will be ignored in this example. However, the detailed procedure to calculate the reduced live loads is explained in the “[wide-Module Joist System](#)” example.

### 3.1. Determination of factored loads

#### Interior Column (Column #1):

Assume 4 story building

Tributary area for interior column is  $A_{Tributary} = (18 \times 14) = 252 \text{ ft}^2$

$$P_u = 4 \times q_u \times A_{Tributary} = 4 \times 0.193 \times 252 = 194.5 \text{ kips}$$

$M_{u,x} = 3.66 \text{ ft-kips}$  (see the previous Table)

$M_{u,y} = 2.23 \text{ ft-kips}$  (see the previous Table)

#### Edge (Exterior) Column (Column #2):

Tributary area for interior column is  $A_{Tributary} = (18 / 2 \times 14) = 126 \text{ ft}^2$

$$P_u = 4 \times q_u \times A_{Tributary} = 4 \times 0.193 \times 126 = 97.3 \text{ kips}$$

$M_{u,x} = 22.08 \text{ ft-kips}$  (see the previous Table)

$M_{u,y} = 1.28 \text{ ft-kips}$  (see the previous Table)

#### Edge (Exterior) Column (Column #3):

Tributary area for interior column is  $A_{Tributary} = (18 \times 14 / 2) = 126 \text{ ft}^2$

$$P_u = 4 \times q_u \times A_{Tributary} = 4 \times 0.193 \times 126 = 97.3 \text{ kips}$$

$M_{u,x} = 2.04 \text{ ft-kips}$  (see the previous Table)

$M_{u,y} = 12.49 \text{ ft-kips}$  (see the previous Table)

#### Corner Column (Column #4):

Tributary area for interior column is  $A_{Tributary} = (18 / 2 \times 14 / 2) = 63 \text{ ft}^2$

$$P_u = 4 \times q_u \times A_{Tributary} = 4 \times 0.193 \times 63 = 48.6 \text{ kips}$$

$M_{u,x} = 12.39 \text{ ft-kips}$  (see the previous Table)

$M_{u,y} = 6.79 \text{ ft-kips}$  (see the previous Table)

The factored loads are then input into spColumn to construct the axial load – moment interaction diagram.

### 3.2. Column Capacity Diagram (Axial-Moment Interaction Diagram)

Interior Column (Column #1):

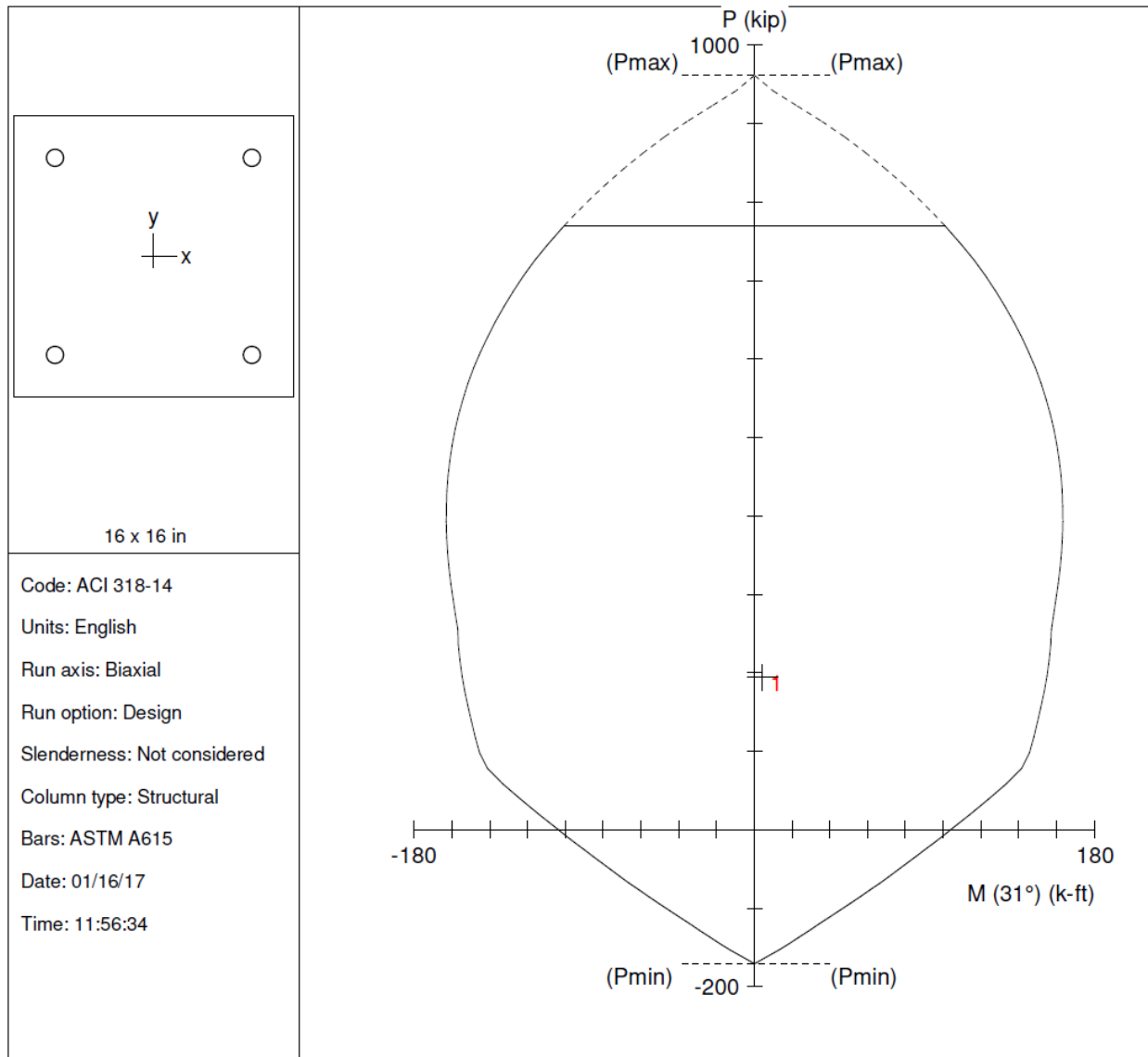

STRUCTUREPOINT - spColumn v5.50 (TM). Licensed to: StructurePoint. License ID: 00000-0000000-4-25EF2-2C6B6

File: C:\TSDA\Two-Way Flat Plate System\Columns Design\Interior Column (#1).col

Project: Two-Way Flat Plate System

Column: Interior #1

Engineer: SP

$f'_c = 6$  ksi

$f_y = 60$  ksi

$A_g = 256$  in<sup>2</sup>

4 #8 bars

$E_c = 4415$  ksi

$E_s = 29000$  ksi

$A_s = 3.16$  in<sup>2</sup>

$\rho = 1.23\%$

$f_c = 5.1$  ksi

$e_{yt} = 0.00206897$  in/in

$X_o = 0.00$  in

$I_x = 5461.33$  in<sup>4</sup>

$e_u = 0.003$  in/in

$Y_o = 0.00$  in

$I_y = 5461.33$  in<sup>4</sup>

Beta1 = 0.75

Min clear spacing = 10.25 in

Clear cover = 1.88 in

Confinement: Tied

$\phi(a) = 0.8$ ,  $\phi(b) = 0.9$ ,  $\phi(c) = 0.65$

Edge Column (Column #2):

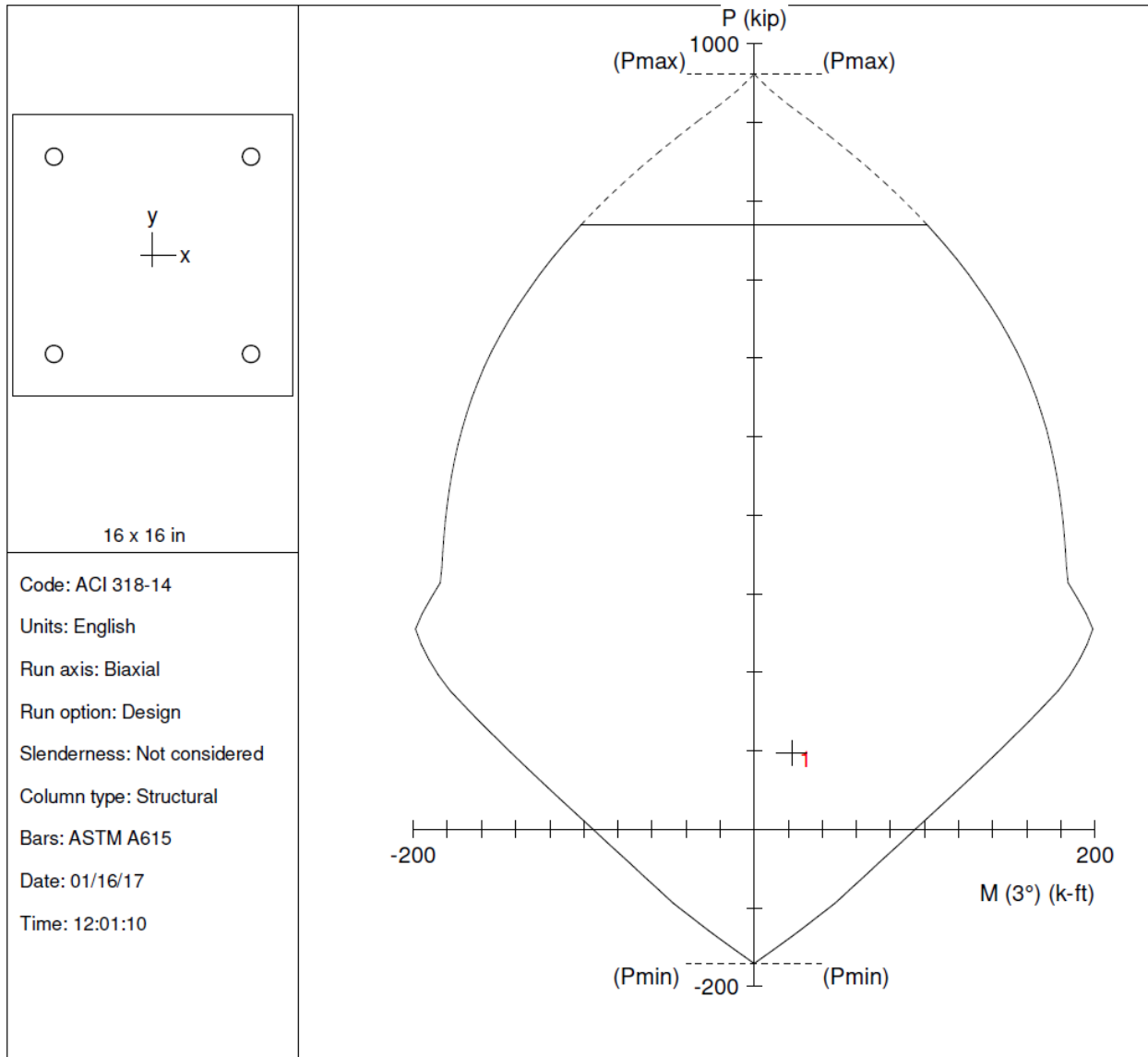

Code: ACI 318-14  
 Units: English  
 Run axis: Biaxial  
 Run option: Design  
 Slenderness: Not considered  
 Column type: Structural  
 Bars: ASTM A615  
 Date: 01/16/17  
 Time: 12:01:10

STRUCTUREPOINT - spColumn v5.50 (TM). Licensed to: StructurePoint. License ID: 00000-0000000-4-25EF2-2C6B6

File: C:\TSDA\Two-Way Flat Plate System\Columns Design\Edge Column (#2).col  
 Project: Two-Way Flat Plate System  
 Column: Interior #1  
 Engineer: SP  
 f'c = 6 ksi      fy = 60 ksi      Ag = 256 in<sup>2</sup>      4 #8 bars  
 Ec = 4415 ksi      Es = 29000 ksi      As = 3.16 in<sup>2</sup>      rho = 1.23%  
 fc = 5.1 ksi      e\_yt = 0.00206897 in/in      Xo = 0.00 in      lx = 5461.33 in<sup>4</sup>  
 e\_u = 0.003 in/in      Yo = 0.00 in      ly = 5461.33 in<sup>4</sup>  
 Beta1 = 0.75      Min clear spacing = 10.25 in      Clear cover = 1.88 in  
 Confinement: Tied  
 phi(a) = 0.8, phi(b) = 0.9, phi(c) = 0.65



Edge Column (Column #3):

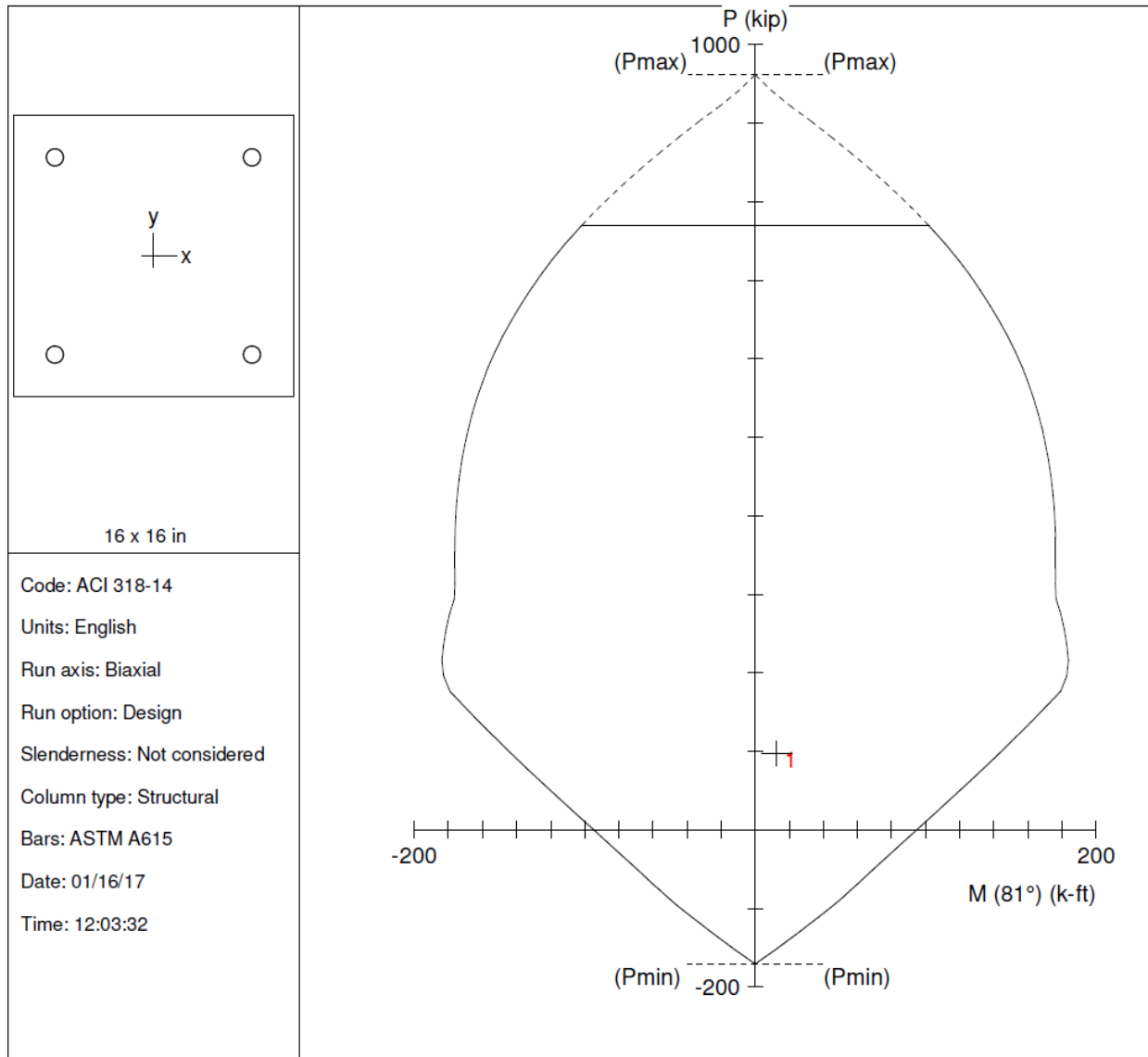

16 x 16 in

Code: ACI 318-14  
Units: English  
Run axis: Biaxial  
Run option: Design  
Slenderness: Not considered  
Column type: Structural  
Bars: ASTM A615  
Date: 01/16/17  
Time: 12:03:32

STRUCTUREPOINT - spColumn v5.50 (TM). Licensed to: StructurePoint. License ID: 00000-0000000-4-25EF2-2C6B6

File: C:\TSDA\Two-Way Flat Plate System\Columns Design\Edge Column (#3).col

Project: Two-Way Flat Plate System

Column: Interior #1

Engineer: SP

$f'_c = 6$  ksi

$f_y = 60$  ksi

$A_g = 256$  in<sup>2</sup>

4 #8 bars

$E_c = 4415$  ksi

$E_s = 29000$  ksi

$A_s = 3.16$  in<sup>2</sup>

$\rho = 1.23\%$

$f_c = 5.1$  ksi

$e_{yt} = 0.00206897$  in/in

$X_o = 0.00$  in

$I_x = 5461.33$  in<sup>4</sup>

$e_u = 0.003$  in/in

$Y_o = 0.00$  in

$I_y = 5461.33$  in<sup>4</sup>

Beta1 = 0.75

Min clear spacing = 10.25 in

Clear cover = 1.88 in

Confinement: Tied

$\phi(a) = 0.8$ ,  $\phi(b) = 0.9$ ,  $\phi(c) = 0.65$

Corner Column (Column #4):

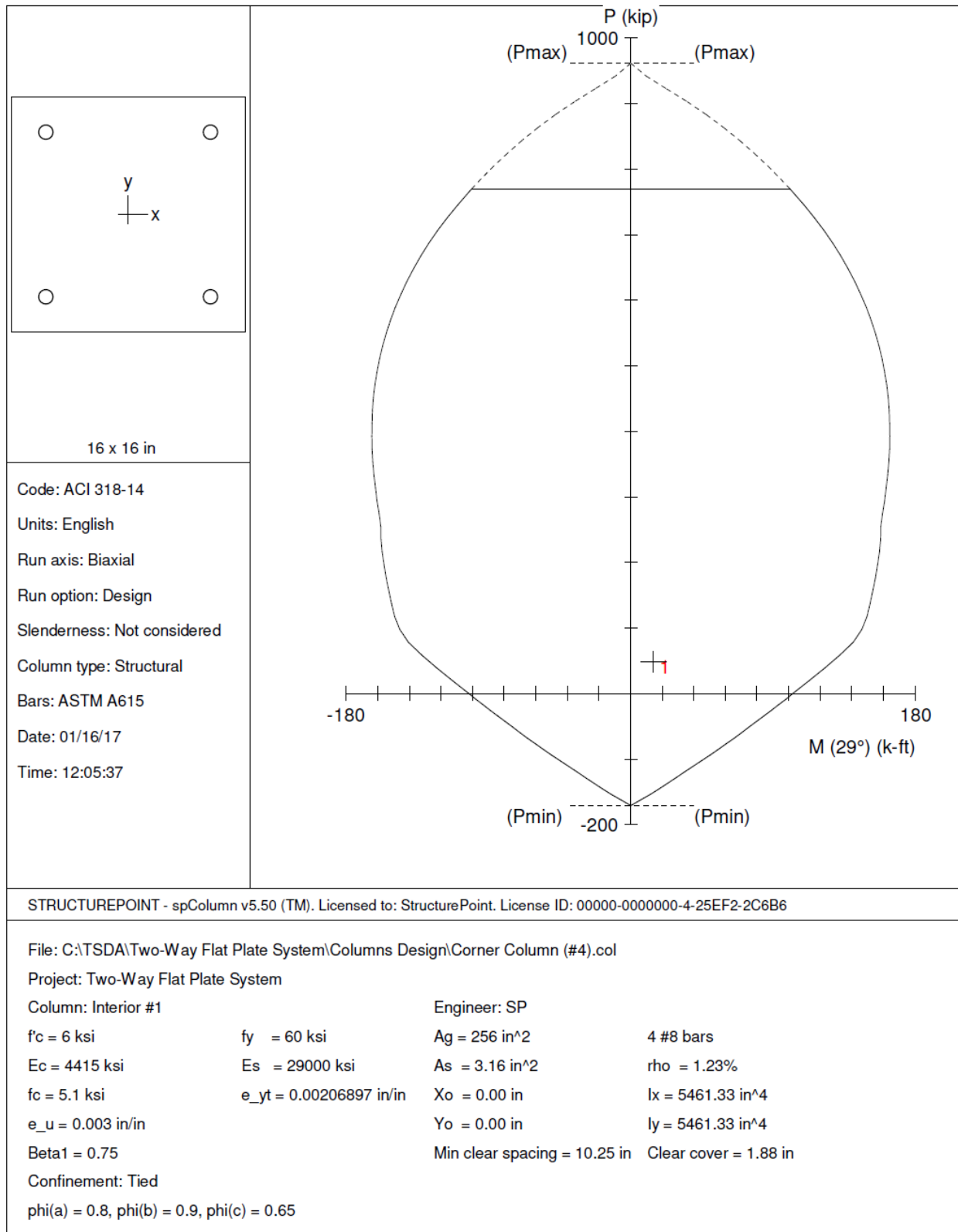

#### 4. Two-Way Slab Shear Strength

Shear strength of the slab in the vicinity of columns/supports includes an evaluation of one-way shear (beam action) and two-way shear (punching) in accordance with ACI 318 Chapter 22.

##### 4.1. One-Way (Beam action) Shear Strength

ACI 318-14 (22.5)

One-way shear is critical at a distance  $d$  from the face of the column as shown in Figure 3. Figure 11 shows the factored shear forces ( $V_u$ ) at the critical sections around each column. In members without shear reinforcement, the design shear capacity of the section equals to the design shear capacity of the concrete:

$$\phi V_n = \phi V_c + \phi V_s = \phi V_c \quad , \quad (\phi V_s = 0) \quad \text{ACI 318-14 (Eq. 22.5.1.1)}$$

Where:

$$\phi V_c = \phi 2\lambda \sqrt{f'_c} b_w d \quad \text{ACI 318-14 (Eq. 22.5.5.1)}$$

$\lambda = 1$  for normal weight concrete

$$\phi V_c = 0.75 \times 2 \times 1.0 \times \frac{\sqrt{4000}}{1000} \times (14 \times 12) \times 5.75 = 91.64 \text{ kips}$$

Because  $\phi V_c \geq V_u$  at all the critical sections, the slab has adequate one-way shear strength.

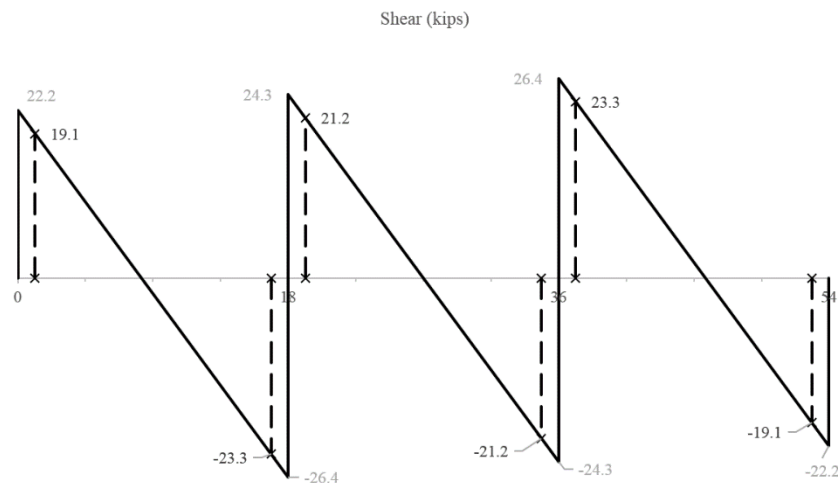

Figure 11 – One-way shear at critical sections (at distance  $d$  from the face of the supporting column)

#### 4.2. Two-Way (Punching) Shear Strength

ACI 318-14 (22.6)

Two-way shear is critical on a rectangular section located at  $d/2$  away from the face of the column as shown in Figure 5.

##### **a. Exterior column:**

The factored shear force ( $V_u$ ) in the critical section is computed as the reaction at the centroid of the critical section minus the self-weight and any superimposed surface dead and live load acting within the critical section ( $d/2$  away from column face).

$$V_u = 22.2 - 0.193 \left( \frac{21.72 \times 18.88}{144} \right) = 21.65 \text{ kips}$$

The factored unbalanced moment used for shear transfer,  $M_{unb}$ , is computed as the sum of the joint moments to the left and right. Moment of the vertical reaction with respect to the centroid of the critical section is also taken into account.

$$M_{unb} = 46.6 - 21.65 \left( \frac{18.88 - 5.99 - 16/2}{12} \right) = 37.8 \text{ kips-ft}$$

For the exterior column in Figure 5, the location of the centroidal axis z-z is:

$$c_{AB} = \frac{\text{moment of area of the sides about AB}}{\text{area of the sides}} = \frac{2(18.8 \times 5.75 \times 18.8/2)}{2 \times 18.8 \times 5.75 + 21.75 \times 5.75} = 5.99 \text{ in.}$$

The polar moment  $J_c$  of the shear perimeter is:

$$J_c = 2 \left( \frac{b_1 d^3}{12} + \frac{d b_1^3}{12} + (b_1 d) \left( \frac{b_1}{2} - c_{AB} \right)^2 \right) + b_2 d c_{AB}^2$$

$$J_c = 2 \left( \frac{18.88 \times 5.75^3}{12} + \frac{5.75 \times 18.88^3}{12} + (18.88 \times 5.75) \left( \frac{18.88}{2} - 5.99 \right)^2 \right) + 21.75 \times 5.75 \times 5.99^2 = 14109 \text{ in.}^4$$

$$\gamma_v = 1 - \gamma_f = 1 - 0.617 = 0.383$$

ACI 318-14 (Eq. 8.4.4.2.2)

The length of the critical perimeter for the exterior column:

$$b_o = 2 \times (16 + 5.75/2) + (16 + 5.75) = 59.5 \text{ in.}$$

The two-way shear stress ( $v_u$ ) can then be calculated as:

$$v_u = \frac{V_u}{b_o \times d} + \frac{\gamma_v M_{unb} c_{AB}}{J_c} \quad \text{ACI 318-14 (R.8.4.4.2.3)}$$

$$v_u = \frac{21.65 \times 1000}{59.5 \times 5.75} + \frac{0.383 \times (37.8 \times 12 \times 1000) \times 5.99}{14109} = 137.0 \text{ psi}$$

$$v_c = \min \left[ 4\lambda\sqrt{f'_c}, \left( 2 + \frac{4}{\beta} \right) \lambda\sqrt{f'_c}, \left( \frac{\alpha_s d}{b_o} + 2 \right) \lambda\sqrt{f'_c} \right] \quad \text{ACI 318-14 (Table 22.6.5.2)}$$

$$v_c = \min \left[ 4 \times 1 \times \sqrt{4000}, \left( 2 + \frac{4}{1} \right) \times 1 \times \sqrt{4000}, \left( \frac{40 \times 5.75}{59.5} + 2 \right) \times 1 \times \sqrt{4000} \right]$$

$$v_c = \min[253, 279.5, 371] \text{ psi} = 253 \text{ psi}$$

$$\phi v_c = 0.75 \times 253 = 189.7 \text{ psi}$$

Since  $\phi v_c \geq v_u$  at the critical section, the slab has adequate two-way shear strength at this joint.

**b. Interior column:**

$$V_u = 24.3 + 26.4 - 0.193 \left( \frac{21.72 \times 21.72}{144} \right) = 50.07 \text{ kips}$$

$$M_{unb} = 84 - 76.2 - 50.07(0) = 7.8 \text{ kips-ft}$$

For the interior column in Figure 5, the location of the centroidal axis z-z is:

$$c_{AB} = \frac{b_1}{2} = \frac{21.75}{2} = 10.88 \text{ in.}$$

The polar moment  $J_c$  of the shear perimeter is:

$$J_c = 2 \left( \frac{b_1 d^3}{12} + \frac{d b_1^3}{12} + (b_1 d) \left( \frac{b_1}{2} - c_{AB} \right)^2 \right) + 2b_2 d c_{AB}^2$$

$$J_c = 2 \left( \frac{21.75 \times 5.75^3}{12} + \frac{5.75 \times 21.75^3}{12} + (21.75 \times 5.75)(0)^2 \right) + 2 \times 21.75 \times 5.75 \times 5.99^2 = 40131 \text{ in.}^4$$

$$\gamma_v = 1 - \gamma_f = 1 - 0.600 = 0.400 \quad \text{ACI 318-14 (Eq. 8.4.4.2.2)}$$

The length of the critical perimeter for the interior column:

$$b_o = 2 \times (16 + 5.75) + 2 \times (16 + 5.75) = 87 \text{ in.}$$

$$v_u = \frac{V_u}{b_o \times d} + \frac{\gamma_v M_{\text{unb}} c_{AB}}{J_c} \quad \text{ACI 318-14 (R.8.4.4.2.3)}$$

$$v_u = \frac{50.07 \times 1000}{87 \times 5.75} + \frac{0.400 \times 7.8 \times 12 \times 1000 \times 10.88}{40131} = 110.2 \text{ psi}$$

$$v_c = \min \left[ 4\lambda\sqrt{f'_c}, \left( 2 + \frac{4}{\beta} \right) \lambda\sqrt{f'_c}, \left( \frac{\alpha_s d}{b_o} + 2 \right) \lambda\sqrt{f'_c} \right] \quad \text{ACI 318-14 (Table 22.6.5.2)}$$

$$v_c = \min \left[ 4 \times 1 \times \sqrt{4000}, \left( 2 + \frac{4}{1} \right) \times 1 \times \sqrt{4000}, \left( \frac{40 \times 5.75}{87} + 2 \right) \times 1 \times \sqrt{4000} \right]$$

$$v_c = \min[253, 279.5, 293.7] \text{ psi} = 253 \text{ psi}$$

$$\phi v_c = 0.75 \times 253 = 189.7 \text{ psi}$$

Since  $\phi v_c \geq v_u$  at the critical section, the slab has adequate two-way shear strength at this joint.

### **c. Corner column:**

In this example, interior equivalent frame strip was selected where it only have exterior and interior supports (no corner supports are included in this strip). However, the two-way shear strength of corner supports usually governs. Thus, the two-way shear strength for the corner column in this example will be checked for educational purposes. Same procedure is used to find the reaction and factored unbalanced moment used for shear transfer at the centroid of the critical section for the corner support for the exterior equivalent frame strip.

$$V_u = 13.18 - 0.193 \left( \frac{18.88 \times 18.88}{144} \right) = 12.70 \text{ kips}$$

$$M_{\text{unb}} = 25.75 - 12.70 \left( \frac{18.88 - 4.72 - 16/2}{12} \right) = 19.23 \text{ kips-ft}$$

For the corner column in Figure 5, the location of the centroidal axis z-z is:

$$c_{AB} = \frac{\text{moment of area of the sides about AB}}{\text{area of the sides}} = \frac{(18.8 \times 5.75 \times 18.8/2)}{2 \times 18.8 \times 5.75} = 4.72 \text{ in.}$$

The polar moment  $J_c$  of the shear perimeter is:

$$J_c = \left( \frac{b_1 d^3}{12} + \frac{d b_1^3}{12} + \left( b_1 d \right) \left( \frac{b_1}{2} - c_{AB} \right)^2 \right) + b_2 d c_{AB}^2$$

$$J_c = \left( \frac{18.88 \times 5.75^3}{12} + \frac{5.75 \times 18.88^3}{12} + (18.88 \times 5.75) \left( \frac{18.88}{2} - 5.99 \right)^2 \right) + 18.88 \times 5.75 \times 4.72^2 = 8354 \text{ in.}^4$$

$$\gamma_v = 1 - \gamma_f = 1 - 0.600 = 0.400$$

ACI 318-14 (Eq. 8.4.4.2.2)

Where:

$$\gamma_f = \frac{1}{1 + (2/3) \times \sqrt{b_1/b_2}}$$

ACI 318-14 (8.4.2.3.2)

$$\gamma_f = \frac{1}{1 + (2/3) \times \sqrt{18.88/18.88}} = 0.600$$

The length of the critical perimeter for the exterior column:

$$b_o = (16 + 5.75/2) + (16 + 5.75/2) = 37.75 \text{ in.}$$

The two-way shear stress ( $v_u$ ) can then be calculated as:

$$v_u = \frac{V_u}{b_o \times d} + \frac{\gamma_v M_{\text{unb}^c AB}}{J_c}$$

ACI 318-14 (R.8.4.4.2.3)

$$v_u = \frac{12.70 \times 1000}{37.75 \times 5.75} + \frac{0.400 \times (19.23 \times 12 \times 1000) \times 4.72}{8354} = 110.6 \text{ psi}$$

$$v_c = \min \left[ 4\lambda\sqrt{f'_c}, \left( 2 + \frac{4}{\beta} \right) \lambda\sqrt{f'_c}, \left( \frac{\alpha_s d}{b_o} + 2 \right) \lambda\sqrt{f'_c} \right]$$

ACI 318-14 (Table 22.6.5.2)

$$v_c = \min \left[ 4 \times 1 \times \sqrt{4000}, \left( 2 + \frac{4}{1} \right) \times 1 \times \sqrt{4000}, \left( \frac{20 \times 5.75}{37.75} + 2 \right) \times 1 \times \sqrt{4000} \right]$$

$$v_c = \min[253, 279.5, 319.2] \text{ psi} = 253 \text{ psi}$$

$$\phi v_c = 0.75 \times 253 = 189.7 \text{ psi}$$

Since  $\phi v_c \geq v_u$  at the critical section, the slab has adequate two-way shear strength at this joint.

## 5. Two-Way Slab Deflection Control (Serviceability Requirements)

Since the slab thickness was selected based on the minimum slab thickness tables in ACI 318-14, the deflection calculations are not required. However, the calculations of immediate and time-dependent deflections are covered in this section for illustration and comparison with spSlab model results.

### 5.1. Immediate (Instantaneous) Deflections

The calculation of deflections for two-way slabs is challenging even if linear elastic behavior can be assumed. Elastic analysis for three service load levels ( $D$ ,  $D + L_{sustained}$ ,  $D+L_{Full}$ ) is used to obtain immediate deflections of the two-way slab in this example. However, other procedures may be used if they result in predictions of deflection in reasonable agreement with the results of comprehensive tests. ACI 318-14 (24.2.3)

The effective moment of inertia ( $I_e$ ) is used to account for the cracking effect on the flexural stiffness of the slab.  $I_e$  for uncracked section ( $M_{cr} > M_a$ ) is equal to  $I_g$ . When the section is cracked ( $M_{cr} < M_a$ ), then the following equation should be used:

$$I_e = \left( \frac{M_{cr}}{M_a} \right)^3 I_g + \left[ 1 - \left( \frac{M_{cr}}{M_a} \right)^3 \right] I_{cr} \leq I_g \quad \text{ACI 318-14 (Eq. 24.2.3.5a)}$$

Where:

$M_a$  = Maximum moment in member due to service loads at stage deflection is calculated.

The values of the maximum moments for the three service load levels are calculated from structural analysis as shown previously in this document. These moments are shown in Figure 12.

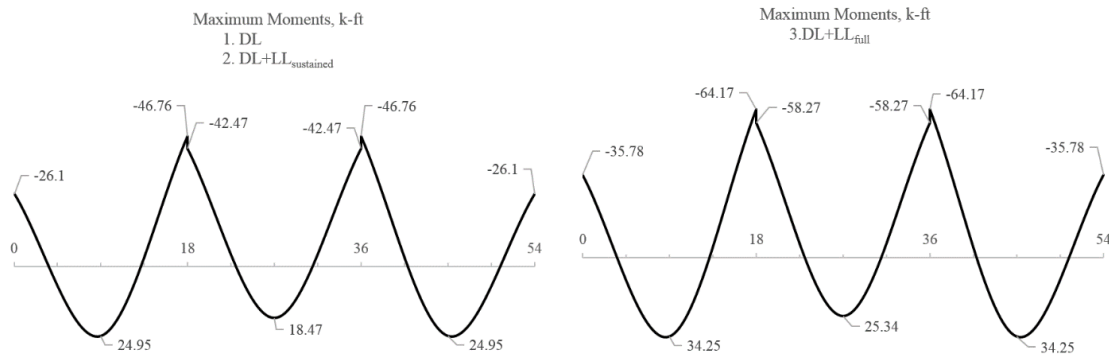

Figure 12 – Maximum Moments for the Three Service Load Levels

$M_{cr}$  = cracking moment.

$$M_{cr} = \frac{f_r I_g}{y_t} = \frac{474.34 \times 4802}{3.5} \times \frac{1}{12 \times 1000} = 54.23 \text{ kip-ft} \quad \text{ACI 318-14 (Eq. 24.2.3.5b)}$$

$f_r$  = Modulus of rupture of concrete.

$$f_r = 7.5 \lambda \sqrt{f'_c} = 7.5 \times 1.0 \times \sqrt{4000} = 474.34 \text{ psi} \quad \text{ACI 318-14 (Eq. 19.2.3.1)}$$



$I_g$  = Moment of inertia of the gross uncracked concrete section

$$I_g = \frac{l_2 h^3}{12} = \frac{(14 \times 12)(7)^3}{12} = 4802 \text{ in}^2$$

$$y_t = \frac{h}{2} = \frac{7}{2} = 3.5 \text{ in}$$

$I_{cr}$  = moment of inertia of the cracked section transformed to concrete PCA Notes on ACI 318-11 (9.5.2.2)

The calculations shown below are for the design strip (frame strip). The values of these parameters for column and middle strips are shown in Table 9.

As calculated previously, the exterior span frame strip near the interior support is reinforced with 17 #4 bars located at 1.25 in. along the section from the top of the slab. Figure 13 shows all the parameters needed to calculate the moment of inertia of the cracked section transformed to concrete.

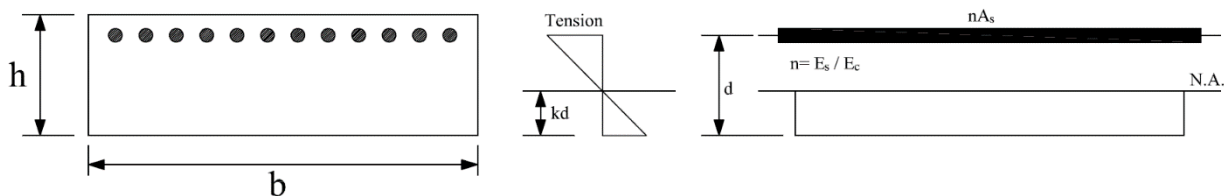

Figure 13 – Cracked Transformed Section

$E_{cs}$  = Modulus of elasticity of slab concrete.

$$E_{cs} = w_c^{1.5} 33 \sqrt{f'_c} = 150^{1.5} \times 33 \times \sqrt{4000} = 3834 \times 10^3 \text{ psi} \quad \text{ACI 318-14 (19.2.2.1.a)}$$

$$n = \frac{E_s}{E_{cs}} = \frac{29000000}{3834000} = 7.56 \quad \text{PCA Notes on ACI 318-11 (Table 10-2)}$$

$$B = \frac{b}{n A_s} = \frac{14 \times 12}{7.56 \times (17 \times 0.2)} = 6.54 \text{ in.}^{-1} \quad \text{PCA Notes on ACI 318-11 (Table 10-2)}$$

$$kd = \frac{\sqrt{2dB + 1} - 1}{B} = \frac{\sqrt{2 \times 5.75 \times 6.54 + 1} - 1}{6.54} = 1.18 \text{ in.} \quad \text{PCA Notes on ACI 318-11 (Table 10-2)}$$

$$I_{cr} = \frac{b(kd)^3}{3} + n A_s (d - kd)^2 \quad \text{PCA Notes on ACI 318-11 (Table 10-2)}$$

$$I_{cr} = \frac{14 \times 12 \times (1.18)^3}{3} + 7.56 \times (17 \times 0.2)(5.75 - 1.18)^2 = 629 \text{ in.}^4$$

The effective moment of inertia procedure described in the Code is considered sufficiently accurate to estimate deflections. The effective moment of inertia,  $I_e$ , was developed to provide a transition between the upper and

lower bounds of  $I_g$  and  $I_{cr}$  as a function of the ratio  $M_{cr}/M_a$ . For conventionally reinforced (nonprestressed) members, the effective moment of inertia,  $I_e$ , shall be calculated by Eq. (24.2.3.5a) unless obtained by a more comprehensive analysis.

$I_e$  shall be permitted to be taken as the value obtained from Eq. (24.2.3.5a) at midspan for simple and continuous spans, and at the support for cantilevers. ACI 318-14 (24.2.3.7)

For continuous one-way slabs and beams.  $I_e$  shall be permitted to be taken as the average of values obtained from Eq. (24.2.3.5a) for the critical positive and negative moment sections. ACI 318-14 (24.2.3.6)

For the exterior span (span with one end continuous) with service load level ( $D+LL_{full}$ ):

$$I_e^- = \left( \frac{M_{cr}}{M_a} \right)^3 I_g + \left[ 1 - \left( \frac{M_{cr}}{M_a} \right)^3 \right] I_{cr}, \text{ since } M_{cr} = 54.23 \text{ kip-ft} < M_a = 64.17 \text{ kip-ft}$$

ACI 318-14 (24.2.3.5a)

Where  $I_e^-$  is the effective moment of inertia for the critical negative moment section (near the support).

$$I_e^- = \left( \frac{54.23}{64.17} \right)^3 \times 4802 + \left[ 1 - \left( \frac{54.23}{64.17} \right)^3 \right] \times 629 = 3148 \text{ in.}^4$$

$$I_e^+ = I_g = 4802 \text{ in.}^4, \text{ since } M_{cr} = 54.23 \text{ kip-ft} > M_a = 34.25 \text{ kip-ft}$$

Where  $I_e^+$  is the effective moment of inertia for the critical positive moment section (midspan).

Since midspan stiffness (including the effect of cracking) has a dominant effect on deflections, midspan section is heavily represented in calculation of  $I_e$  and this is considered satisfactory in approximate deflection calculations. The averaged effective moment of inertia ( $I_{e,avg}$ ) is given by:

$$I_{e,avg} = 0.85I_e^+ + 0.15I_e^- \quad \text{PCA Notes on ACI 318-11 (9.5.2.4(1))}$$

$$I_{e,avg} = 0.85(4802) + 0.15(3148) = 4554 \text{ in.}^4$$

For the interior span (span with both ends continuous) with service load level ( $D+LL_{full}$ ):

$$I_{e,l}^- = I_{e,R}^- = \left( \frac{M_{cr}}{M_a} \right)^3 I_g + \left[ 1 - \left( \frac{M_{cr}}{M_a} \right)^3 \right] I_{cr}, \text{ since } M_{cr} = 54.23 \text{ kip-ft} < M_a = 58.27 \text{ kip-ft}$$

ACI 318-14 (24.2.3.5a)

Where  $I_{e,l}^-$  and  $I_{e,R}^-$  are the effective moment of inertia for the critical negative moment sections near the left and right supports, respectively.

$$I_e^- = \left(\frac{54.23}{58.27}\right)^3 \times 4802 + \left[1 - \left(\frac{54.23}{58.27}\right)^3\right] \times 629 = 3993 \text{ in.}^4$$

$$I_e^+ = I_g = 4802 \text{ in.}^4, \text{ since } M_{cr} = 54.23 \text{ kip-ft} > M_a = 25.34 \text{ kip-ft}$$

Where  $I_e^+$  is the effective moment of inertia for the critical positive moment section (midspan).

The averaged effective moment of inertia ( $I_{e,avg}$ ) is given by:

$$I_{e,avg} = 0.70 I_e^+ + 0.15 (I_{e,l}^- + I_{e,r}^-) \quad \text{PCA Notes on ACI 318-11 (9.5.2.4(2))}$$

$$I_{e,avg} = 0.70 (4802) + 0.15 (3993 + 3993) = 4559 \text{ in.}^4$$

Table 9 provides a summary of the required parameters and calculated values needed for deflections for exterior and interior equivalent frame. It also provides a summary of the same values for column strip and middle strip to facilitate calculation of panel deflection.

Table 9 – Averaged Effective Moment of Inertia Calculations													
For Frame Strip													
Span	zone	$I_g$ , in. <sup>4</sup>	$I_{cr}$ , in. <sup>4</sup>	$M_a$ , kips-ft			$M_{cr}$ , k-ft	$I_e$ , in. <sup>4</sup>			$I_{e,avg}$ , in. <sup>4</sup>		
				D	D + LL <sub>Sus</sub>	D + L <sub>full</sub>		D	D + LL <sub>Sus</sub>	D + L <sub>full</sub>	D	D + LL <sub>Sus</sub>	D + L <sub>full</sub>
Ext	Left	4802	499	-26.10	-26.10	-35.78	54.23	4802	4802	4802	4802	4802	4554
	Midspan		465	24.95	24.95	34.25		4802	4802	4802			
	Right		629	-46.76	-46.76	-64.17		4802	4802	3148			
Int	Left		629	-42.47	-42.47	-58.27		4802	4802	3993	4802	4802	4559
	Mid		465	18.47	18.47	25.34		4802	4802	4802			
	Right		629	-42.47	-42.47	-58.27		4802	4802	3993			

Deflections in two-way slab systems shall be calculated taking into account size and shape of the panel, conditions of support, and nature of restraints at the panel edges. For immediate deflections two-way slab systems the midpanel deflection is computed as the sum of deflection at midspan of the column strip or column line in one direction ( $\Delta_{cx}$  or  $\Delta_{cy}$ ) and deflection at midspan of the middle strip in the orthogonal direction ( $\Delta_{mx}$  or  $\Delta_{my}$ ). Figure 14 shows the deflection computation for a rectangular panel. The average  $\Delta$  for panels that have different properties in the two direction is calculated as follows:

$$\Delta = \frac{\left( \Delta_{cx} + \Delta_{my} \right) + \left( \Delta_{cy} + \Delta_{mx} \right)}{2}$$

PCA Notes on ACI 318-11 (9.5.3.4 Eq. 8)

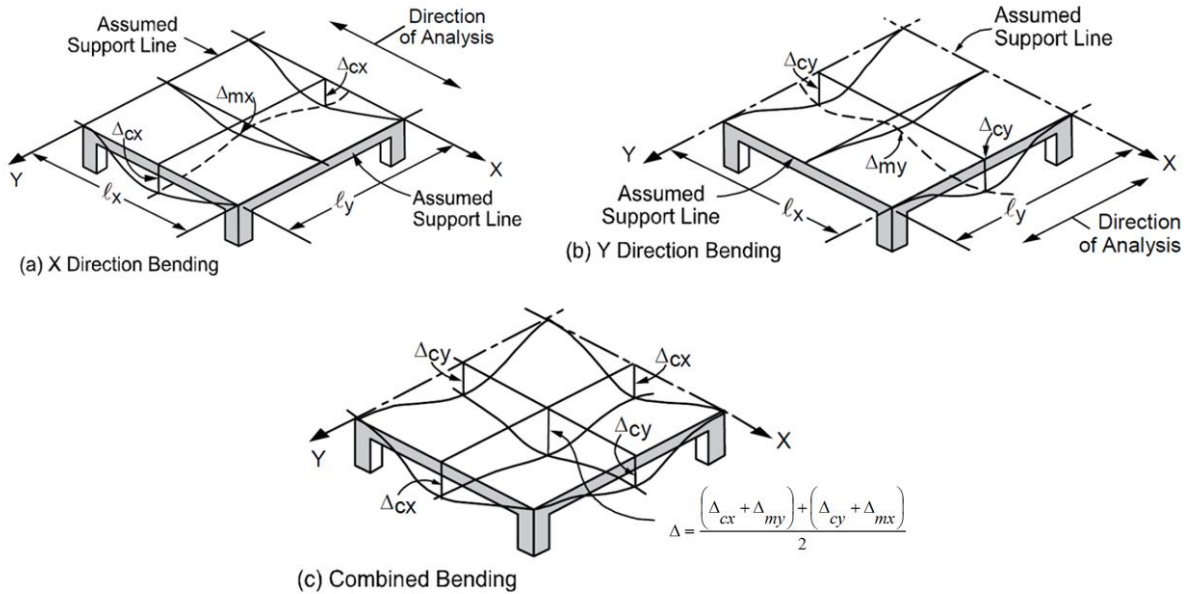

Figure 14 – Deflection Computation for a rectangular Panel

To calculate each term of the previous equation, the following procedure should be used. Figure 15 shows the procedure of calculating the term  $\Delta_{cx}$ . same procedure can be used to find the other terms.

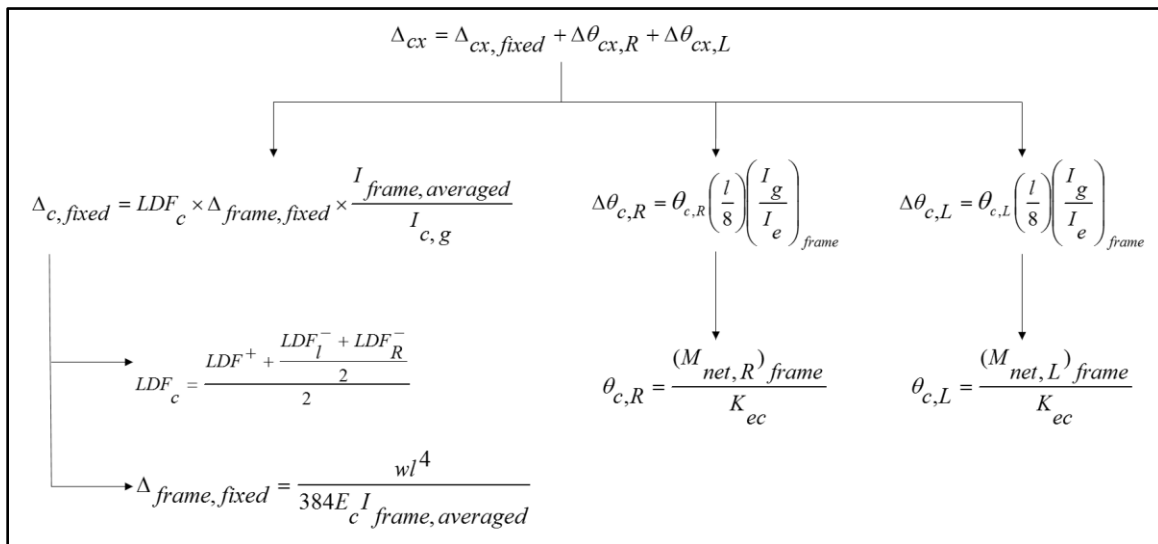

Figure 15 –  $\Delta_{cx}$  calculation procedure

For exterior span - service dead load case:

$$\Delta_{frame, fixed} = \frac{wl^4}{384E_c I_{frame, averaged}} \quad \text{PCA Notes on ACI 318-11 (9.5.3.4 Eq. 10)}$$

Where:

$\Delta_{frame, fixed}$  = Deflection of column strip assuming fixed end condition.

$$w = (20 + 150 \times 7 / 12)(14) = 1505 \text{ lb/ft}$$

$$E_c = w_c^{1.5} 33 \sqrt{f'_c} = 150^{1.5} \times 33 \times \sqrt{4000} = 3834 \times 10^3 \text{ psi} \quad \text{ACI 318-14 (19.2.2.1.a)}$$

$I_{frame, averaged}$  = The averaged effective moment of inertia ( $I_{e,avg}$ ) for the frame strip for service dead load case from Table 9 = 4802 in.<sup>4</sup>

$$\Delta_{frame, fixed} = \frac{(1505)(18)^4(12)^3}{384(3834 \times 10^3)(4802)} = 0.039 \text{ in.}$$

$$\Delta_{c, fixed} = LDF_c \times \Delta_{frame, fixed} \times \frac{I_{frame, averaged}}{I_{c, g}} \quad \text{PCA Notes on ACI 318-11 (9.5.3.4 Eq. 11)}$$

Where  $LDF_c$  is the load distribution factor for the column strip. The load distribution factor for the column strip can be found from the following equation:

$$LDF_c = \frac{LDF_c^+ + \frac{LDF_l^- + LDF_R^-}{2}}{2}$$

And the load distribution factor for the middle strip can be found from the following equation:

$$LDF_m = 1 - LDF_c$$

For the end span, LDF for exterior negative region ( $LDF_L^-$ ), interior negative region ( $LDF_R^-$ ), and positive region ( $LDF_L^+$ ) are 1.00, 0.75, and 0.60, respectively (From Table 6 of this document). Thus, the load distribution factor for the column strip for the end span is given by:

$$LDF_c = \frac{0.6 + \frac{1.0 + 0.75}{2}}{2} = 0.738$$

$I_{c, g}$  = The gross moment of inertia ( $I_g$ ) for the column strip for service dead load = 2401 in.<sup>4</sup>

$$\Delta_{c, fixed} = LDF_c \times \Delta_{frame, fixed} \times \frac{I_{frame, averaged}}{I_{c, g}} = 0.738 \times 0.039 \times \frac{4802}{2401} = 0.057 \text{ in.}$$

$$\theta_{c, L} = \frac{(M_{net, L})_{frame}}{K_{ec}} \quad \text{PCA Notes on ACI 318-11 (9.5.3.4 Eq. 12)}$$

Where:

$\theta_{c, L}$  = rotation of the span left support.

$(M_{net, L})_{frame} = 26.3 \text{ kip-ft}$  = Net frame strip negative moment of the left support.

$K_{ec}$  = effective column stiffness =  $553.7 \times 10^6$  in.-lb (calculated previously).

$$\theta_{c, L} = \frac{26.3 \times 12 \times 1000}{553.7 \times 10^6} = 0.0006 \text{ rad}$$

$$\Delta\theta_{c, L} = \theta_{c, L} \left( \frac{l}{8} \right) \left( \frac{I_g}{I_e} \right)_{frame} \quad \text{PCA Notes on ACI 318-11 (9.5.3.4 Eq. 14)}$$

Where:

$\Delta\theta_{c, L}$  = midspan deflection due to rotation of left support.

$$\left( \frac{I_g}{I_e} \right)_{frame} = \text{Gross moment of inertia-to-effective moment of inertia ratio for frame strip.}$$

$$\Delta\theta_{c, L} = 0.0006 \times \frac{18 \times 12}{8} \times \frac{4802}{4802} = 0.0161 \text{ in.}$$

$$\theta_{c, R} = \frac{(M_{net, R})_{frame}}{K_{ec}} = \frac{(46.76 - 42.47) \times 12 \times 1000}{553.7 \times 10^6} = 0.00010 \text{ rad}$$

Where

$\theta_{c, R}$  = rotation of the span right support.

$(M_{net, R})_{frame}$  = Net frame strip negative moment of the right support.

$$\Delta\theta_{c,R} = \theta_{c,R} \left( \frac{l}{8} \right) \left( \frac{I_g}{I_e} \right)_{frame} = 0.00010 \times \frac{18 \times 12}{8} \times \frac{4802}{4802} = 0.0027 \text{ in.}$$

Where:

$\Delta\theta_{c,R}$  = midspan deflection due to rotation of right support.

$$\Delta_{cx} = \Delta_{cx, fixed} + \Delta\theta_{cx,R} + \Delta\theta_{cx,L} \quad \text{\textit{PCA Notes on ACI 318-11 (9.5.3.4 Eq. 9)}}$$

$$\Delta_{cx} = 0.057 + 0.0027 + 0.0161 = 0.076 \text{ in.}$$

Following the same procedure,  $\Delta_{mx}$  can be calculated for the middle strip. This procedure is repeated for the equivalent frame in the orthogonal direction to obtain  $\Delta_{cy}$ , and  $\Delta_{my}$  for the end and middle spans for the other load levels ( $D+LL_{sus}$  and  $D+LL_{full}$ ).

Assuming square panel,  $\Delta_{cx} = \Delta_{cy} = 0.076 \text{ in.}$  and  $\Delta_{mx} = \Delta_{my} = 0.039 \text{ in.}$  Then the total

The average  $\Delta$  for the corner panel is calculated as follows:

$$\Delta = \frac{\left( \Delta_{cx} + \Delta_{my} \right) + \left( \Delta_{cy} + \Delta_{mx} \right)}{2} = \left( \Delta_{cx} + \Delta_{my} \right) = \left( \Delta_{cy} + \Delta_{mx} \right) = 0.076 + 0.039 = 0.115 \text{ in.}$$

**Table 10 – Immediate (Instantaneous) Deflections in the x-direction**

**Column Strip**

Span	LDF	D						
		$\Delta_{\text{frame-fixed}}$ , in.	$\Delta_{\text{c-fixed}}$ , in.	$\theta_{\text{c1}}$ , rad	$\theta_{\text{c2}}$ , rad	$\Delta\theta_{\text{c1}}$ , in.	$\Delta\theta_{\text{c2}}$ , in.	$\Delta_{\text{cxs}}$ , in.
Ext	0.738	0.0386	0.0570	0.00059	0.00010	0.0161	0.0027	0.076
Int	0.675	0.0386	0.0521	-0.00010	-0.00010	-0.0027	-0.0027	0.047

**Middle Strip**

LDF	D						
	$\Delta_{\text{frame-fixed}}$ , in.	$\Delta_{\text{m-fixed}}$ , in.	$\theta_{\text{m1}}$ , rad	$\theta_{\text{m2}}$ , rad	$\Delta\theta_{\text{m1}}$ , in.	$\Delta\theta_{\text{m2}}$ , in.	$\Delta_{\text{mx}}$ , in.
0.262	0.0386	0.0202	0.00059	0.00010	0.0161	0.0027	0.039
0.325	0.0386	0.0251	-0.00010	-0.00010	-0.0027	-0.0027	0.020

Span	LDF	D+LL <sub>sus</sub>						
		$\Delta_{\text{frame-fixed}}$ , in.	$\Delta_{\text{c-fixed}}$ , in.	$\theta_{\text{c1}}$ , rad	$\theta_{\text{c2}}$ , rad	$\Delta\theta_{\text{c1}}$ , in.	$\Delta\theta_{\text{c2}}$ , in.	$\Delta_{\text{cxs}}$ , in.
Ext	0.738	0.0386	0.0570	0.00059	0.00010	0.0161	0.0027	0.076
Int	0.675	0.0386	0.0521	-0.00010	-0.00010	-0.0027	-0.0027	0.047

LDF	D+LL <sub>sus</sub>						
	$\Delta_{\text{frame-fixed}}$ , in.	$\Delta_{\text{m-fixed}}$ , in.	$\theta_{\text{m1}}$ , rad	$\theta_{\text{m2}}$ , rad	$\Delta\theta_{\text{m1}}$ , in.	$\Delta\theta_{\text{m2}}$ , in.	$\Delta_{\text{mx}}$ , in.
0.262	0.0386	0.0202	0.00059	0.00010	0.0161	0.0027	0.039
0.325	0.0386	0.0251	-0.00010	-0.00010	-0.0027	-0.0027	0.020

Span	LDF	D+LL <sub>full</sub>						
		$\Delta_{\text{frame-fixed}}$ , in.	$\Delta_{\text{c-fixed}}$ , in.	$\theta_{\text{c1}}$ , rad	$\theta_{\text{c2}}$ , rad	$\Delta\theta_{\text{c1}}$ , in.	$\Delta\theta_{\text{c2}}$ , in.	$\Delta_{\text{cxs}}$ , in.
Ext	0.738	0.0559	0.0825	0.00082	0.00014	0.02333	0.00388	0.110
Int	0.675	0.0558	0.0753	-0.00014	-0.00014	-0.00387	-0.00387	0.068

LDF	D+LL <sub>full</sub>						
	$\Delta_{\text{frame-fixed}}$ , in.	$\Delta_{\text{m-fixed}}$ , in.	$\theta_{\text{m1}}$ , rad	$\theta_{\text{m2}}$ , rad	$\Delta\theta_{\text{m1}}$ , in.	$\Delta\theta_{\text{m2}}$ , in.	$\Delta_{\text{mx}}$ , in.
0.262	0.0559	0.0293	0.00082	0.00014	0.02333	0.00388	0.017
0.325	0.0558	0.0363	-0.00014	-0.00014	-0.00387	-0.00387	0.009

Span	LDF	LL
		$\Delta_{\text{cxs}}$ , in.
Ext	0.738	0.034
Int	0.675	0.021

LDF	LL
	$\Delta_{\text{mx}}$ , in.
0.262	0.017
0.325	0.009



From the analysis in the transverse direction the deflection values below are obtained:

For DL loading case:

$$\Delta_{my}$$

$$\Delta_{cy}$$

For DL+LL<sub>sust</sub> loading case:

$$\Delta_{my}$$

$$\Delta_{cy}$$

For DL+LL<sub>full</sub> loading case:

$$\Delta_{my}$$

$$\Delta_{cy}$$

These values for the x-direction are shown in Table 10. Then, the total midpanel deflection is calculated by combining the contributions of the column and middle strip deflections from the X and Y directions:

$$\Delta = \frac{\left( \Delta_{cx} + \Delta_{my} \right) + \left( \Delta_{cy} + \Delta_{mx} \right)}{2} \quad \text{PCA Notes on ACI 318-11 (9.5.3.4 Eq. 8)}$$

## 5.2. Time-Dependent (Long-Term) Deflections ( $\Delta_{lt}$ )

The additional time-dependent (long-term) deflection resulting from creep and shrinkage ( $\Delta_{cs}$ ) may be estimated as follows:

$$\Delta_{cs} = \lambda_{\Delta} \times (\Delta_{sust})_{inst} \quad \text{PCA Notes on ACI 318-11 (9.5.2.5 Eq. 4)}$$

The total time-dependent (long-term) deflection is calculated as:

$$(\Delta_{total})_{lt} = (\Delta_{sust})_{inst} \times (1 + \lambda_{\Delta}) + [(\Delta_{total})_{inst} - (\Delta_{sust})_{inst}] \quad \text{CSA A23.3-04 (N9.8.2.5)}$$

Where:

$(\Delta_{sust})_{inst}$  = Immediate (instantaneous) deflection due to sustained load, in.

$$\lambda_{\Delta} = \frac{\xi}{1 + 50\rho'} \quad \text{ACI 318-14 (24.2.4.1.1)}$$

$(\Delta_{total})_{lt}$  = Time-dependent (long-term) total deflection, in.

$$(\Delta_{total})_{Inst} = \text{Total immediate (instantaneous) deflection, in.}$$

For the exterior span

$\xi = 2$ , consider the sustained load duration to be 60 months or more. ACI 318-14 (Table 24.2.4.1.3)

$\rho' = 0$ , conservatively.

$$\lambda_{\Delta} = \frac{2}{1 + 50 \times 0} = 2$$

$$\Delta_{cs} = 2 \times 0.076 = 0.152 \text{ in.}$$

$$(\Delta_{total})_{lt} = 0.076 \times (1 + 2) + (0.110 - 0.076) = 0.262 \text{ in.}$$

Table 11 shows long-term deflections for the exterior and interior spans for the analysis in the x-direction, for column and middle strips.

<b>Table 11 - Long-Term Deflections</b>					
<b>Column Strip</b>					
<b>Span</b>	<b><math>(\Delta_{sust})_{Inst}</math>, in</b>	<b><math>\lambda_{\Delta}</math></b>	<b><math>\Delta_{cs}</math>, in</b>	<b><math>(\Delta_{total})_{Inst}</math>, in</b>	<b><math>(\Delta_{total})_{lt}</math>, in</b>
<b>Exterior</b>	0.076	2.000	0.152	0.110	0.261
<b>Interior</b>	0.047	2.000	0.095	0.068	0.162
<b>Middle Strip</b>					
<b>Exterior</b>	0.039	2.000	0.078	0.056	0.134
<b>Interior</b>	0.020	2.000	0.041	0.029	0.069

## 6. Computer Program Solution

[spSlab](#) program utilizes the Equivalent Frame Method described and illustrated in details here for modeling, analysis and design of two-way concrete floor slab systems. [spSlab](#) uses the exact geometry and boundary conditions provided as input to perform an elastic stiffness (matrix) analysis of the equivalent frame taking into account the torsional stiffness of the slabs framing into the column. It also takes into account the complications introduced by a large number of parameters such as vertical and torsional stiffness of transverse beams, the stiffening effect of drop panels, column capitals, and effective contribution of columns above and below the floor slab using the of equivalent column concept (ACI 318-14 (R8.11.4)).

[spSlab](#) Program models the equivalent frame as a design strip. The design strip is, then, separated by [spSlab](#) into column and middle strips. The program calculates the internal forces (Shear Force & Bending Moment), moment and shear capacity vs. demand diagrams for column and middle strips, instantaneous and long-term deflection results, and required flexural reinforcement for column and middle strips. The graphical and text results are provided below for both input and output of the [spSlab](#) model.

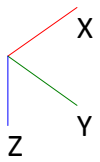
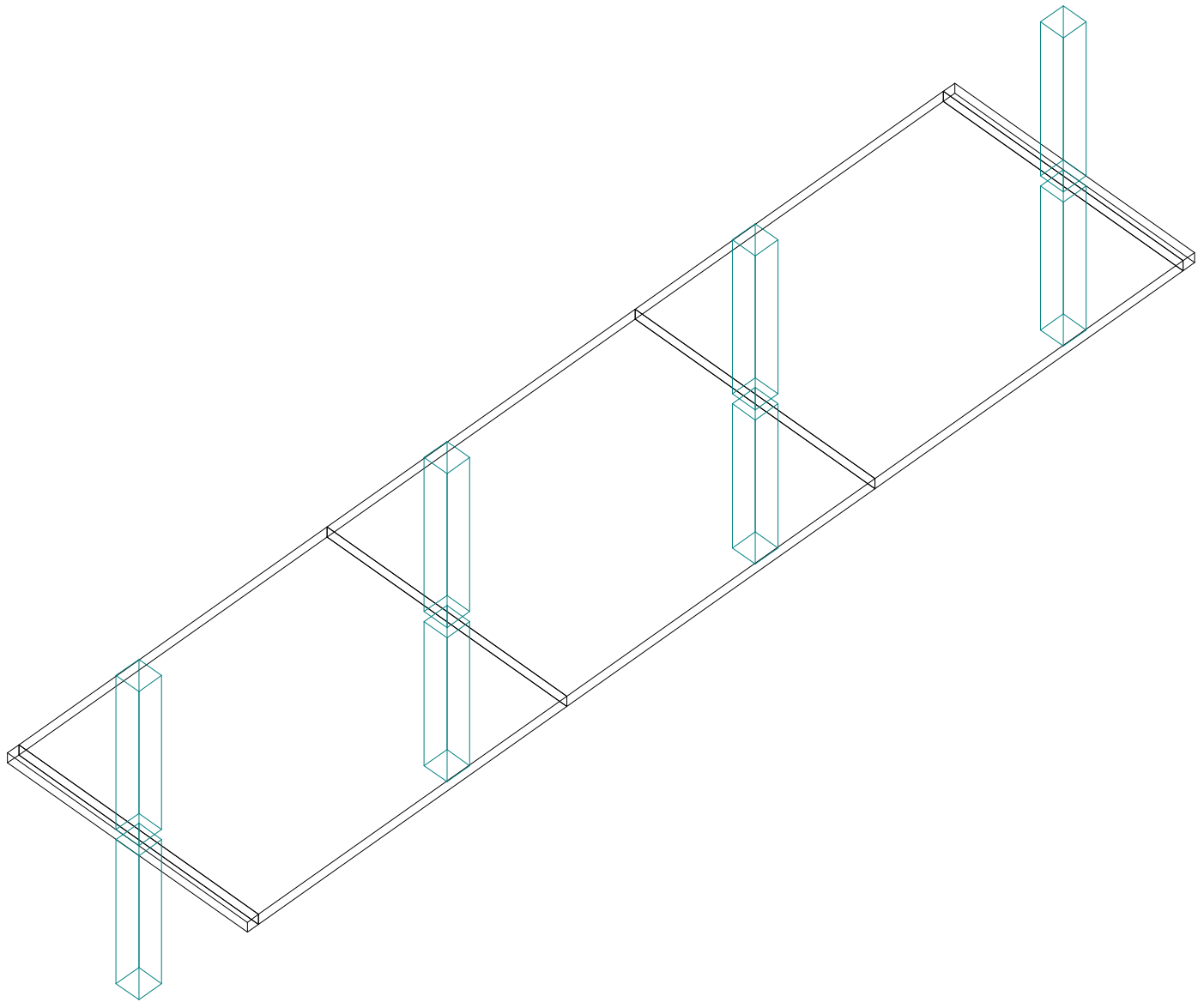

spSlab v5.00. Licensed to: StructurePoint. License ID: 66184-1055152-4-2C6B6-2C6B6

File: C:\TSDA\TSDA-spSlab-Two-Way Flat Plate Floor.slb

Project: Two-Way Flat Plate Floor

Frame: Interior Frame

Engineer: SP

Code: ACI 318-14

Date: 12/19/16

Time: 09:18:18

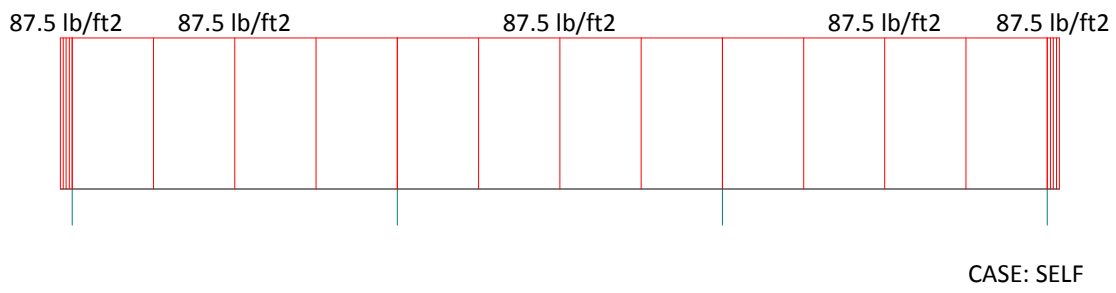
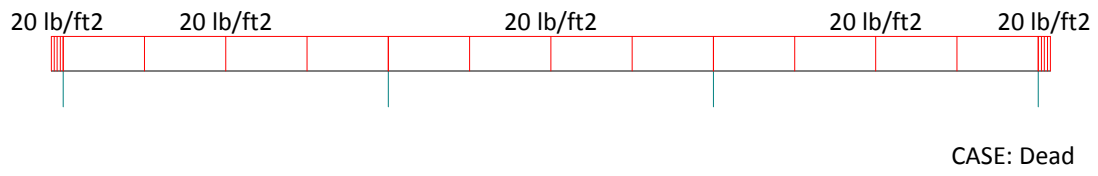
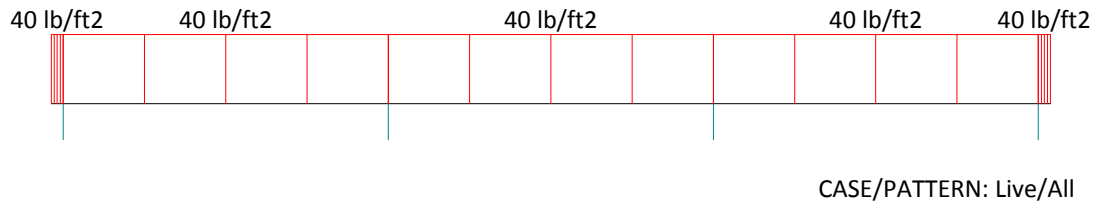

spSlab v5.00. Licensed to: StructurePoint. License ID: 66184-1055152-4-2C6B6-2C6B6

File: C:\TSDA\TSDA-spSlab-Two-Way Flat Plate Floor.slb

Project: Two-Way Flat Plate Floor

Frame: Interior Frame

Engineer: SP

Code: ACI 318-14

Date: 12/19/16

Time: 09:20:52

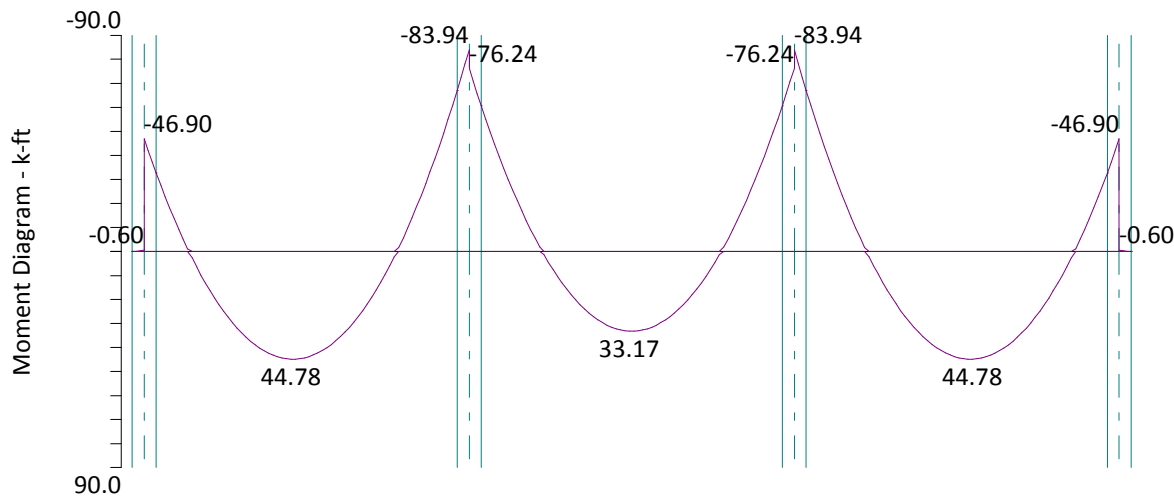
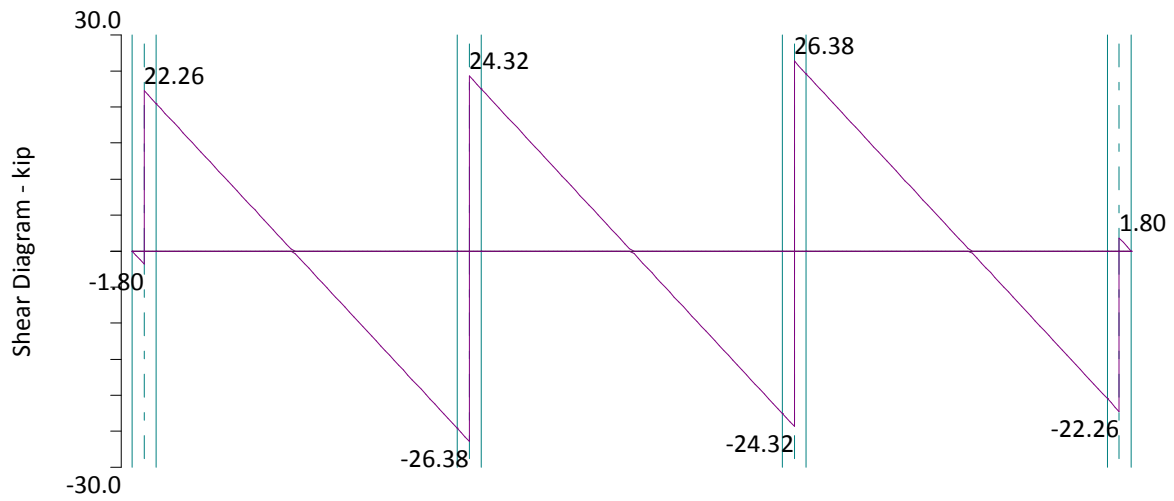

LEGEND:  
— Envelope

spSlab v5.00. Licensed to: StructurePoint. License ID: 66184-1055152-4-2C6B6-2C6B6

File: C:\TSDA\TSDA-spSlab-Two-Way Flat Plate Floor.slb

Project: Two-Way Flat Plate Floor

Frame: Interior Frame

Engineer: SP

Code: ACI 318-14

Date: 12/19/16

Time: 09:22:12

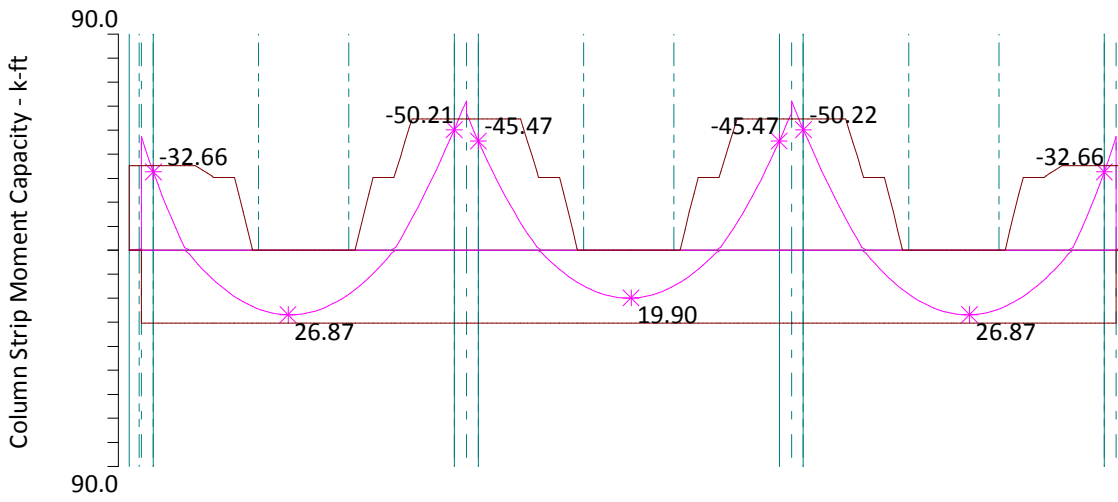
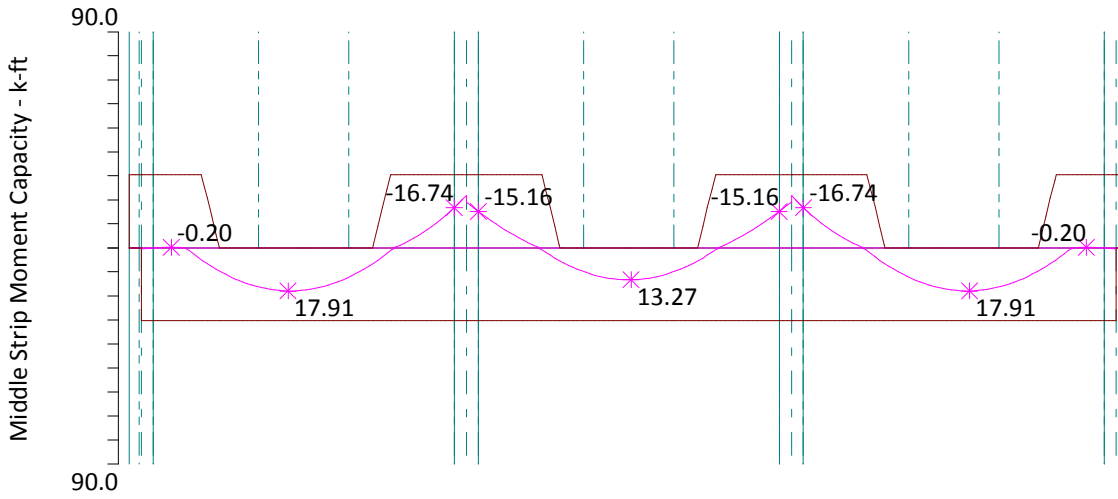

LEGEND:  
 - Envelope Curve  
 - Capacity Curve  
 - - Support Centerline  
 - Face of Support  
 - - Zone Limits

spSlab v5.00. Licensed to: StructurePoint. License ID: 66184-1055152-4-2C6B6-2C6B6

File: C:\TSDA\TSDA-spSlab-Two-Way Flat Plate Floor.slb

Project: Two-Way Flat Plate Floor

Frame: Interior Frame

Engineer: SP

Code: ACI 318-14

Date: 12/19/16

Time: 09:23:11

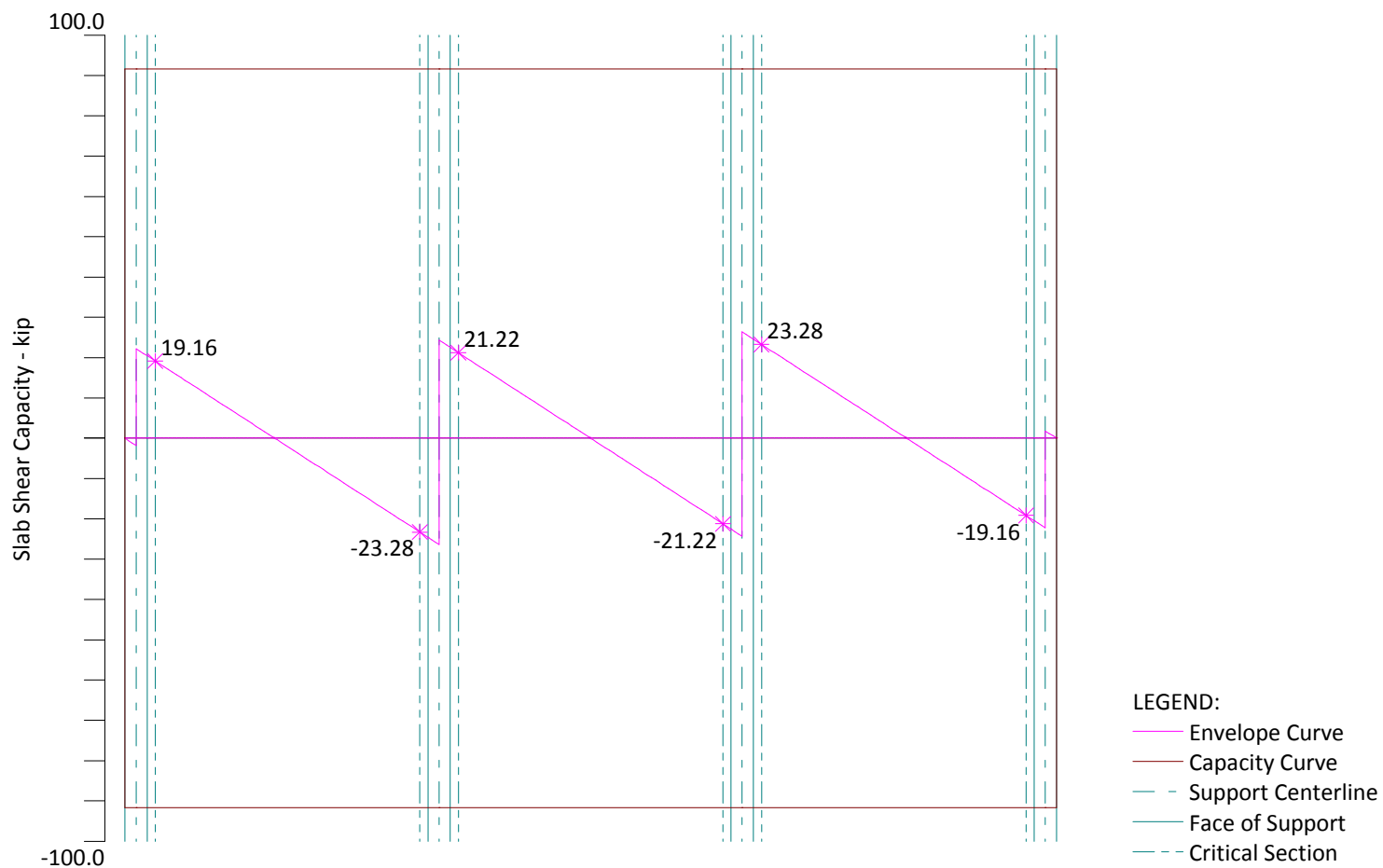

spSlab v5.00. Licensed to: StructurePoint. License ID: 66184-1055152-4-2C6B6-2C6B6

File: C:\TSDA\TSDA-spSlab-Two-Way Flat Plate Floor.slb

Project: Two-Way Flat Plate Floor

Frame: Interior Frame

Engineer: SP

Code: ACI 318-14

Date: 12/19/16

Time: 09:24:00

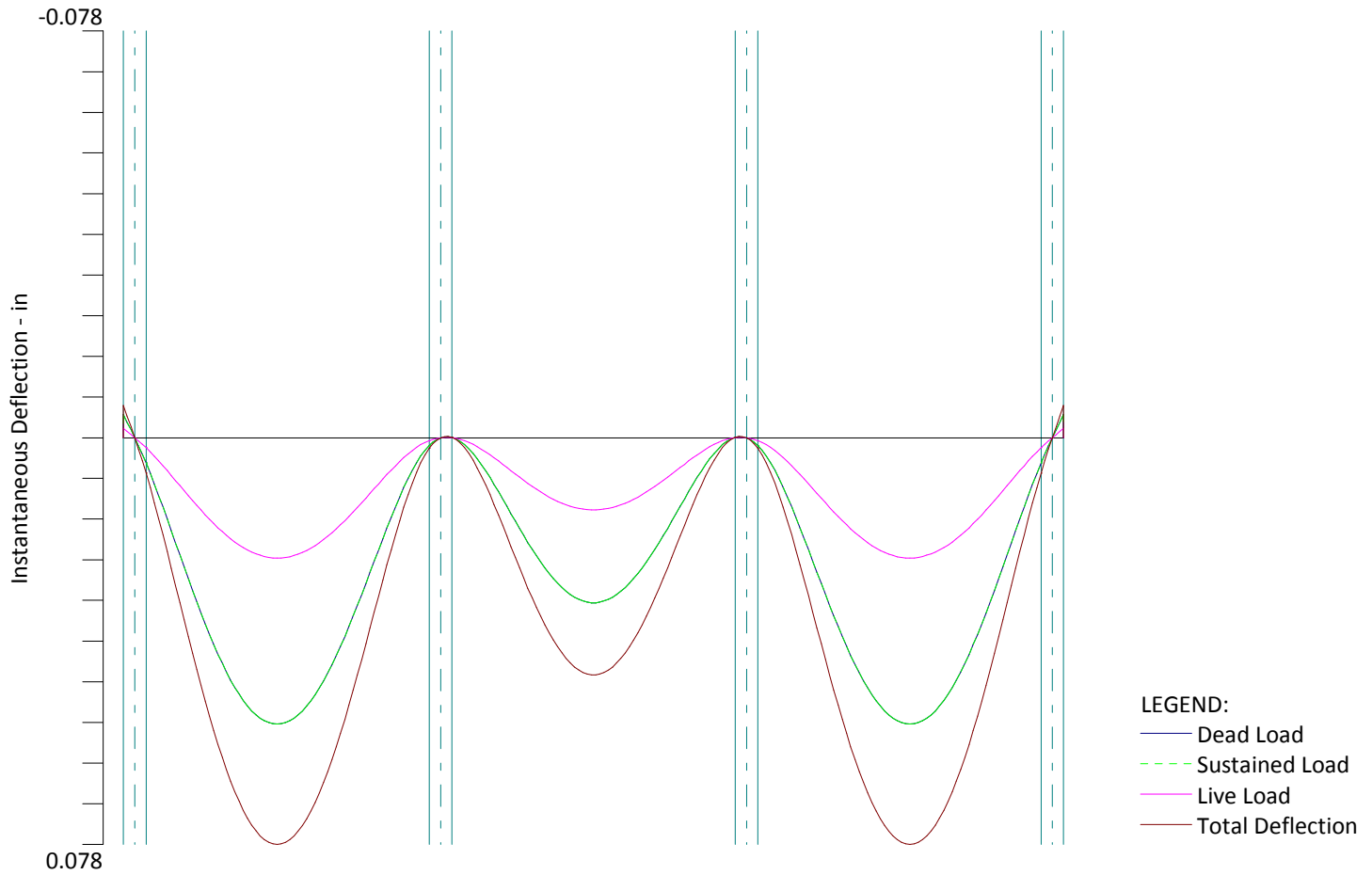

spSlab v5.00. Licensed to: StructurePoint. License ID: 66184-1055152-4-2C6B6-2C6B6

File: C:\TSDA\TSDA-spSlab-Two-Way Flat Plate Floor.slb

Project: Two-Way Flat Plate Floor

Frame: Interior Frame

Engineer: SP

Code: ACI 318-14

Date: 12/19/16

Time: 09:25:54



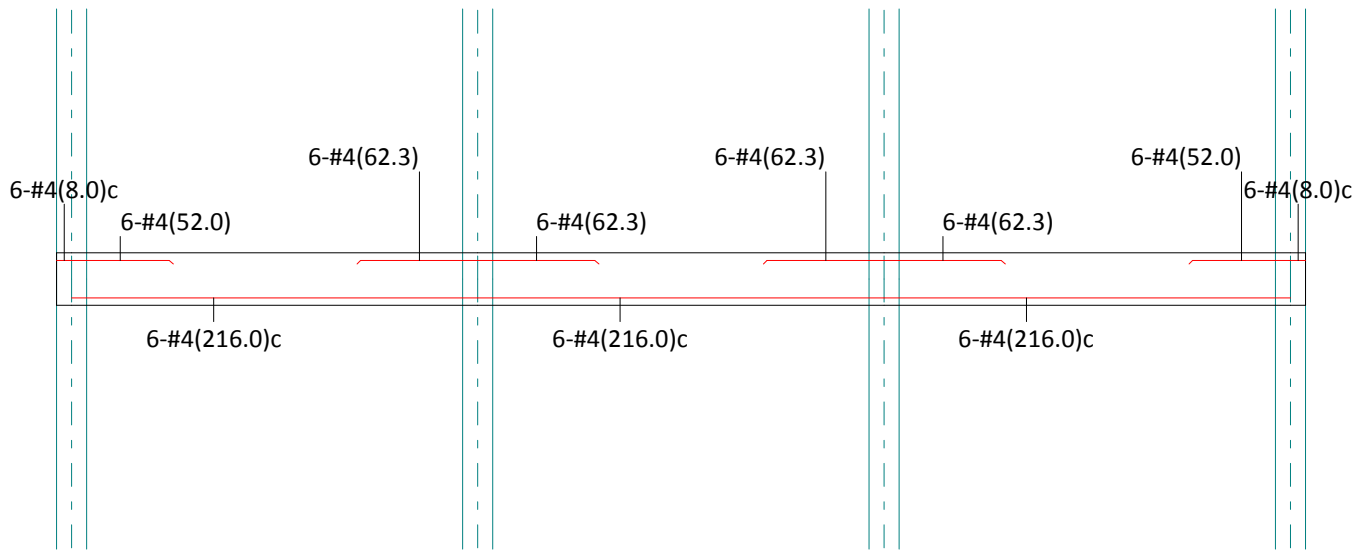

Middle Strip Flexural Reinforcement

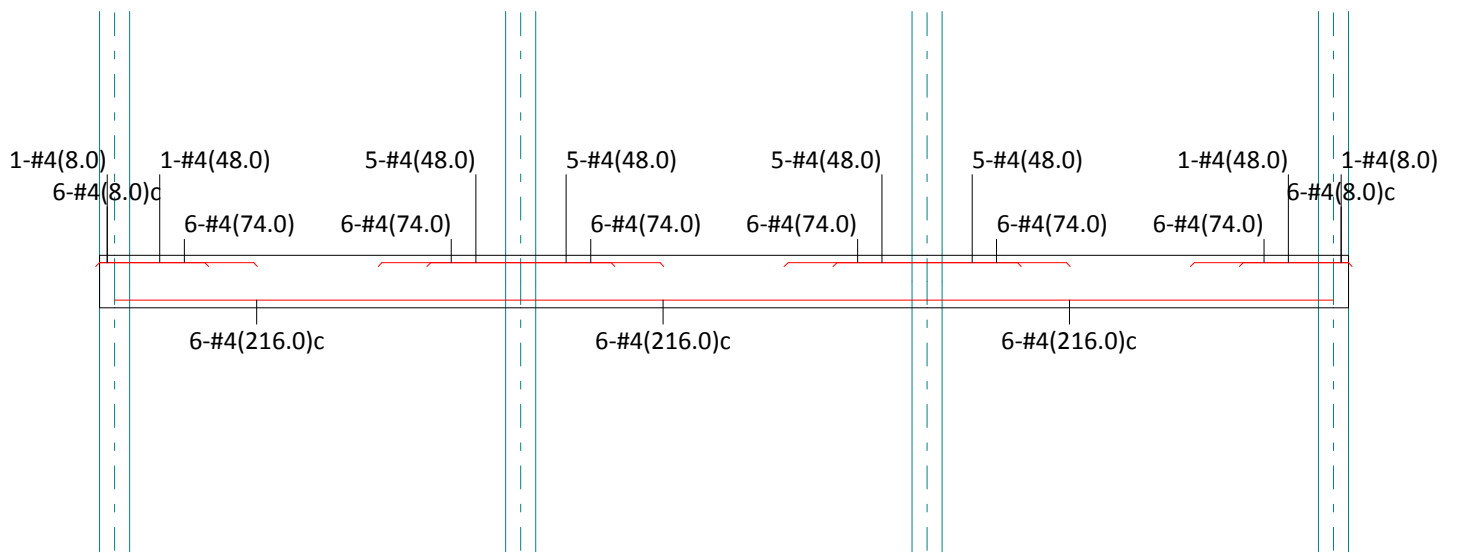

Column Strip Flexural Reinforcement

spSlab v5.00. Licensed to: StructurePoint. License ID: 66184-1055152-4-2C6B6-2C6B6

File: C:\TSDA\TSDA-spSlab-Two-Way Flat Plate Floor.slb

Project: Two-Way Flat Plate Floor

Frame: Interior Frame

Engineer: SP

Code: ACI 318-14

Date: 12/19/16

Time: 09:32:26

```

                oooooo   o
                oo   oo   oo
    oooooo   oooooo   oo   oo   oooooo   oo
    oo   o   oo   oo   oo   oo   o   oo   oo
    oo   oo   oo   ooo   oo   oooooo   oooooo
    oooooo   oo   oo   ooo   oo   oo   oo   oo   oo
    oo   oo   oooooo   oo   oo   oo   oo   oo   oo
    o   oo   oo   oo   oo   oo   o   oo   oo   oo
    oooooo   oo   oooooo   ooo   oooooo   o   oooooo   (TM)
    
```

```

=====
                        spSlab v5.00 (TM)
    A Computer Program for Analysis, Design, and Investigation of
    Reinforced Concrete Beams, One-way and Two-way Slab Systems
    Copyright © 2003-2015, STRUCTUREPOINT, LLC
    All rights reserved
=====
    
```

Licensee stated above acknowledges that STRUCTUREPOINT (SP) is not and cannot be responsible for either the accuracy or adequacy of the material supplied as input for processing by the spSlab computer program. Furthermore, STRUCTUREPOINT neither makes any warranty expressed nor implied with respect to the correctness of the output prepared by the spSlab program. Although STRUCTUREPOINT has endeavored to produce spSlab error free the program is not and cannot be certified infallible. The final and only responsibility for analysis, design and engineering documents is the licensee's. Accordingly, STRUCTUREPOINT disclaims all responsibility in contract, negligence or other tort for any analysis, design or engineering documents prepared in connection with the use of the spSlab program.

```

=====
[1] INPUT ECHO
=====
    
```

General Information

```

=====
File name: C:\TSDA\TSDA-spSlab-Two-Way Flat Plate Floor.slb
Project: Two-Way Flat Plate Floor
Frame: Interior Frame
Engineer: SP
Code: ACI 318-14
Reinforcement Database: ASTM A615
Mode: Design
Number of supports = 4 + Left cantilever + Right cantilever
Floor System: Two-Way
    
```

```

Live load pattern ratio = 0%
Minimum free edge distance for punching shear = 4 times slab thickness.
Circular critical section around circular supports used (if possible).
Deflections are based on cracked section properties.
In negative moment regions, Ig and Mcr DO NOT include flange/slab contribution (if available)
Long-term deflections are calculated for load duration of 60 months.
0% of live load is sustained.
Compression reinforcement calculations NOT selected.
Default incremental rebar design selected.
User-defined slab strip widths NOT selected.
User-defined distribution factors NOT selected.
One-way shear in drop panel NOT selected.
Distribution of shear to strips NOT selected.
Beam T-section design NOT selected.
Longitudinal beam contribution in negative reinforcement design over support NOT selected.
Transverse beam contribution in negative reinforcement design over support NOT selected.
    
```

Material Properties

```

=====
                Slabs|Beams          Columns
                -----
wc   =          150                150 lb/ft3
f'c  =           4                  6 ksi
Ec   =        3834.3              4696 ksi
fr   =        0.47434            0.58095 ksi

fy   =          60 ksi, Bars are not epoxy-coated
fyt  =          60 ksi
Es   =        29000 ksi
    
```

Reinforcement Database

```

=====
Units: Db (in), Ab (in^2), Wb (lb/ft)
Size   Db      Ab      Wb      Size   Db      Ab      Wb
-----
#3     0.38    0.11    0.38    #4     0.50    0.20    0.67
#5     0.63    0.31    1.04    #6     0.75    0.44    1.50
#7     0.88    0.60    2.04    #8     1.00    0.79    2.67
#9     1.13    1.00    3.40    #10    1.27    1.27    4.30
    
```

#11	1.41	1.56	5.31	#14	1.69	2.25	7.65
#18	2.26	4.00	13.60				

Span Data

=====

Slabs

-----

Units: L1, wL, wR, L2L, L2R (ft); t, Hmin (in)

Span Loc	L1	t	wL	wR	L2L	L2R	Hmin
1 Int	0.667	7.00	7.000	7.000	14.000	14.000	--- LC *i
2 Int	18.000	7.00	7.000	7.000	14.000	14.000	6.67
3 Int	18.000	7.00	7.000	7.000	14.000	14.000	6.06
4 Int	18.000	7.00	7.000	7.000	14.000	14.000	6.67
5 Int	0.667	7.00	7.000	7.000	14.000	14.000	--- RC *i

NOTES:

Deflection check required for panels where code-specified Hmin for two-way construction doesn't apply due to:  
 \*i - cantilever end span (LC, RC) support condition

Support Data

=====

Columns

-----

Units: c1a, c2a, c1b, c2b (in); Ha, Hb (ft)

Supp	c1a	c2a	Ha	c1b	c2b	Hb	Red%
1	16.00	16.00	9.000	16.00	16.00	9.000	100
2	16.00	16.00	9.000	16.00	16.00	9.000	100
3	16.00	16.00	9.000	16.00	16.00	9.000	100
4	16.00	16.00	9.000	16.00	16.00	9.000	100

Boundary Conditions

-----

Units: Kz (kip/in); Kry (kip-in/rad)

Supp	Spring Kz	Spring Kry	Far End A	Far End B
1	0	0	Fixed	Fixed
2	0	0	Fixed	Fixed
3	0	0	Fixed	Fixed
4	0	0	Fixed	Fixed

Load Data

=====

Load Cases and Combinations

-----

Case Type	SELF DEAD	Dead DEAD	Live LIVE
U1	1.200	1.200	1.600

Area Loads

-----

Units: Wa (lb/ft2)

Case/Patt	Span	Wa
SELF	1	87.50
	2	87.50
	3	87.50
	4	87.50
	5	87.50
Dead	2	20.00
	3	20.00
	4	20.00
	1	20.00
	5	20.00
Live	2	40.00
	3	40.00
	4	40.00
	1	40.00
	5	40.00

Reinforcement Criteria

=====

Slabs and Ribs

-----

	Top bars		Bottom bars	
	Min	Max	Min	Max
Bar Size	#4	#4	#4	#4
Bar spacing	1.00	18.00	1.00	18.00 in
Reinf ratio	0.18	2.00	0.18	2.00 %
Cover	1.00		1.00	in

There is NOT more than 12 in of concrete below top bars.

Beams

-----

Top bars	Bottom bars	Stirrups
----------	-------------	----------

	Min	Max	Min	Max	Min	Max
	-----	-----	-----	-----	-----	-----
Bar Size	#5	#8	#5	#8	#3	#5
Bar spacing	1.00	18.00	1.00	18.00	6.00	18.00 in
Reinf ratio	0.14	5.00	0.14	5.00 %		
Cover	1.50		1.50	in		
Layer dist.	1.00		1.00	in		
No. of legs					2	6
Side cover					1.50	in
1st Stirrup					3.00	in

There is NOT more than 12 in of concrete below top bars.

```

                oooooo   o
                oo   oo   oo
    oooooo   oooooo   oo   oo   oooooo   oo
    oo   o   oo   oo   oo   oo   o   oo   oo
    oo   oo   oo   ooo   oo   oooooo   oooooo
    oooooo   oo   oo   ooo   oo   oo   oo   oo   oo
    oo   oo   oooooo   oo   oo   oo   oo   oo   oo
    o   oo   oo   oo   oo   oo   o   oo   oo   oo
    oooooo   oo   oooooo   ooo   oooooo   o   oooooo   (TM)
    
```

=====  
 spSlab v5.00 (TM)  
 A Computer Program for Analysis, Design, and Investigation of  
 Reinforced Concrete Beams, One-way and Two-way Slab Systems  
 Copyright © 2003-2015, STRUCTUREPOINT, LLC  
 All rights reserved  
 =====

Licensee stated above acknowledges that STRUCTUREPOINT (SP) is not and cannot be responsible for either the accuracy or adequacy of the material supplied as input for processing by the spSlab computer program. Furthermore, STRUCTUREPOINT neither makes any warranty expressed nor implied with respect to the correctness of the output prepared by the spSlab program. Although STRUCTUREPOINT has endeavored to produce spSlab error free the program is not and cannot be certified infallible. The final and only responsibility for analysis, design and engineering documents is the licensee's. Accordingly, STRUCTUREPOINT disclaims all responsibility in contract, negligence or other tort for any analysis, design or engineering documents prepared in connection with the use of the spSlab program.

=====  
 [2] DESIGN RESULTS\*  
 =====

\*Unless otherwise noted, all results are in the direction of analysis only. Another analysis in the perpendicular direction has to be carried out for two-way slab systems.

Strip Widths and Distribution Factors

Units: Width (ft).

Span	Strip	Width			Moment Factor		
		Left**	Right**	Bottom*	Left**	Right**	Bottom*
1	Column	7.00	7.00	7.00	1.000	1.000	0.600
	Middle	7.00	7.00	7.00	0.000	0.000	0.400
2	Column	7.00	7.00	7.00	1.000	0.750	0.600
	Middle	7.00	7.00	7.00	0.000	0.250	0.400
3	Column	7.00	7.00	7.00	0.750	0.750	0.600
	Middle	7.00	7.00	7.00	0.250	0.250	0.400
4	Column	7.00	7.00	7.00	0.750	1.000	0.600
	Middle	7.00	7.00	7.00	0.250	0.000	0.400
5	Column	7.00	7.00	7.00	1.000	1.000	0.600
	Middle	7.00	7.00	7.00	0.000	0.000	0.400

\*Used for bottom reinforcement. \*\*Used for top reinforcement.

=====  
 Top Reinforcement

Units: Width (ft), Mmax (k-ft), Xmax (ft), As (in^2), Sp (in)

Span	Strip	Zone	Width	Mmax	Xmax	AsMin	AsMax	AsReq	SpProv	Bars	
1	Column	Left	7.00	0.06	0.193	1.058	8.724	0.002	14.000	6-#4 *3	
		Midspan	7.00	0.19	0.358	1.058	8.724	0.007	14.000	6-#4 *3	
		Right	7.00	0.43	0.550	1.058	8.724	0.016	12.000	7-#4 *3	
	Middle	Left	7.00	0.00	0.000	1.058	8.724	0.000	14.000	6-#4 *3	
		Midspan	7.00	0.00	0.275	1.058	8.724	0.000	14.000	6-#4 *3	
		Right	7.00	0.00	0.550	1.058	8.724	0.000	14.000	6-#4 *3	
	2	Column	Left	7.00	32.66	0.667	1.058	8.724	1.293	12.000	7-#4
			Midspan	7.00	0.00	9.000	0.000	8.724	0.000	0.000	---
			Right	7.00	50.21	17.333	1.058	8.724	2.015	7.636	11-#4
Middle		Left	7.00	0.20	1.662	1.058	8.724	0.008	14.000	6-#4 *3	
		Midspan	7.00	0.00	9.000	0.000	8.724	0.000	0.000	---	
		Right	7.00	16.74	17.333	1.058	8.724	0.655	14.000	6-#4 *3	
3	Column	Left	7.00	45.47	0.667	1.058	8.724	1.818	7.636	11-#4	
		Midspan	7.00	0.00	9.000	0.000	8.724	0.000	0.000	---	
		Right	7.00	45.47	17.333	1.058	8.724	1.818	7.636	11-#4	
	Middle	Left	7.00	15.16	0.667	1.058	8.724	0.592	14.000	6-#4 *3	

	Midspan	7.00	0.00	9.000	0.000	8.724	0.000	0.000	---
	Right	7.00	15.16	17.333	1.058	8.724	0.592	14.000	6-#4 *3
4	Column	7.00	50.22	0.667	1.058	8.724	2.015	7.636	11-#4
	Midspan	7.00	0.00	9.000	0.000	8.724	0.000	0.000	---
	Right	7.00	32.66	17.333	1.058	8.724	1.293	12.000	7-#4
	Middle	7.00	16.74	0.667	1.058	8.724	0.655	14.000	6-#4 *3
	Midspan	7.00	0.00	9.000	0.000	8.724	0.000	0.000	---
	Right	7.00	0.20	16.338	1.058	8.724	0.008	14.000	6-#4 *3
5	Column	7.00	0.43	0.117	1.058	8.724	0.016	12.000	7-#4 *3
	Midspan	7.00	0.19	0.309	1.058	8.724	0.007	14.000	6-#4 *3
	Right	7.00	0.06	0.474	1.058	8.724	0.002	14.000	6-#4 *3
	Middle	7.00	0.00	0.117	1.058	8.724	0.000	14.000	6-#4 *3
	Midspan	7.00	0.00	0.392	1.058	8.724	0.000	14.000	6-#4 *3
	Right	7.00	0.00	0.667	1.058	8.724	0.000	14.000	6-#4 *3

NOTES:

\*3 - Design governed by minimum reinforcement.

Top Bar Details

=====

Units: Length (ft)

Span	Strip	Left				Continuous		Right			
		Bars	Length	Bars	Length	Bars	Length	Bars	Length	Bars	Length
1	Column	---		---		6-#4	0.67	1-#4	0.67	---	
	Middle	---		---		6-#4	0.67	---		---	
2	Column	6-#4	6.17	1-#4	4.00	---		6-#4	6.17	5-#4	4.00
	Middle	6-#4	4.33	---		---		6-#4	5.19	---	
3	Column	6-#4	6.17	5-#4	4.00	---		6-#4	6.17	5-#4	4.00
	Middle	6-#4	5.19	---		---		6-#4	5.19	---	
4	Column	6-#4	6.17	5-#4	4.00	---		6-#4	6.17	1-#4	4.00
	Middle	6-#4	5.19	---		---		6-#4	4.33	---	
5	Column	1-#4	0.67	---		6-#4	0.67	---		---	
	Middle	---		---		6-#4	0.67	---		---	

Top Bar Development Lengths

=====

Units: Length (in)

Span	Strip	Left				Continuous		Right			
		Bars	DevLen	Bars	DevLen	Bars	DevLen	Bars	DevLen	Bars	DevLen
1	Column	---		---		6-#4	12.00	1-#4	12.00	---	
	Middle	---		---		6-#4	12.00	---		---	
2	Column	6-#4	12.00	1-#4	12.00	---		6-#4	12.00	5-#4	12.00
	Middle	6-#4	12.00	---		---		6-#4	12.00	---	
3	Column	6-#4	12.00	5-#4	12.00	---		6-#4	12.00	5-#4	12.00
	Middle	6-#4	12.00	---		---		6-#4	12.00	---	
4	Column	6-#4	12.00	5-#4	12.00	---		6-#4	12.00	1-#4	12.00
	Middle	6-#4	12.00	---		---		6-#4	12.00	---	
5	Column	1-#4	12.00	---		6-#4	12.00	---		---	
	Middle	---		---		6-#4	12.00	---		---	

Bottom Reinforcement

=====

Units: Width (ft), Mmax (k-ft), Xmax (ft), As (in^2), Sp (in)

Span	Strip	Width	Mmax	Xmax	As		AsReq	SpProv	Bars
					AsMin	AsMax			
1	Column	7.00	0.00	0.275	0.000	8.724	0.000	0.000	---
	Middle	7.00	0.00	0.275	0.000	8.724	0.000	0.000	---
2	Column	7.00	26.87	8.129	1.058	8.724	1.059	14.000	6-#4
	Middle	7.00	17.91	8.129	1.058	8.724	0.701	14.000	6-#4 *3
3	Column	7.00	19.90	9.124	1.058	8.724	0.780	14.000	6-#4 *3
	Middle	7.00	13.27	9.124	1.058	8.724	0.518	14.000	6-#4 *3
4	Column	7.00	26.87	9.871	1.058	8.724	1.059	14.000	6-#4
	Middle	7.00	17.91	9.871	1.058	8.724	0.701	14.000	6-#4 *3
5	Column	7.00	0.00	0.392	0.000	8.724	0.000	0.000	---
	Middle	7.00	0.00	0.392	0.000	8.724	0.000	0.000	---

NOTES:

\*3 - Design governed by minimum reinforcement.

Bottom Bar Details

=====

Units: Start (ft), Length (ft)

Span Strip	Long Bars			Short Bars		
	Bars	Start	Length	Bars	Start	Length
1 Column	---			---		
Middle	---			---		
2 Column	6-#4	0.00	18.00	---		
Middle	6-#4	0.00	18.00	---		
3 Column	6-#4	0.00	18.00	---		
Middle	6-#4	0.00	18.00	---		
4 Column	6-#4	0.00	18.00	---		
Middle	6-#4	0.00	18.00	---		
5 Column	---			---		
Middle	---			---		

Bottom Bar Development Lengths

Units: DevLen (in)

Span Strip	Long Bars		Short Bars	
	Bars	DevLen	Bars	DevLen
1 Column	---		---	
Middle	---		---	
2 Column	6-#4	12.00	---	
Middle	6-#4	12.00	---	
3 Column	6-#4	12.00	---	
Middle	6-#4	12.00	---	
4 Column	6-#4	12.00	---	
Middle	6-#4	12.00	---	
5 Column	---		---	
Middle	---		---	

Flexural Capacity

Units: x (ft), As (in<sup>2</sup>), PhiMn, Mu (k-ft)

Span Strip	x	Top						Bottom							
		AsTop	PhiMn-	Mu-	Comb	Pat	Status	AsBot	PhiMn+	Mu+	Comb	Pat	Status		
1 Column	0.000	1.40	-35.30	0.00	U1	All	OK	0.00	0.00	0.00	U1	All	OK		
	0.193	1.40	-35.30	-0.06	U1	All	OK	0.00	0.00	0.00	U1	All	OK		
	0.333	1.40	-35.30	-0.17	U1	All	OK	0.00	0.00	0.00	U1	All	OK		
	0.358	1.40	-35.30	-0.19	U1	All	OK	0.00	0.00	0.00	U1	All	OK		
	0.550	1.40	-35.30	-0.43	U1	All	OK	0.00	0.00	0.00	U1	All	OK		
	0.667	1.40	-35.30	-0.60	U1	All	---	0.00	0.00	0.00	U1	All	---		
	Middle	0.000	1.20	-30.37	0.00	U1	All	OK	0.00	0.00	0.00	U1	All	OK	
		0.193	1.20	-30.37	-0.00	U1	All	OK	0.00	0.00	0.00	U1	All	OK	
		0.333	1.20	-30.37	-0.00	U1	All	OK	0.00	0.00	0.00	U1	All	OK	
		0.358	1.20	-30.37	-0.00	U1	All	OK	0.00	0.00	0.00	U1	All	OK	
		0.550	1.20	-30.37	-0.00	U1	All	OK	0.00	0.00	0.00	U1	All	OK	
		0.667	1.20	-30.37	-0.00	U1	All	---	0.00	0.00	0.00	U1	All	---	
		2 Column	0.000	1.40	-35.30	-47.36	U1	All	---	1.20	30.37	0.00	U1	All	---
			0.444	1.40	-35.30	-37.39	U1	All	---	1.20	30.37	0.00	U1	All	---
0.667	1.40		-35.30	-32.66	U1	All	OK	1.20	30.37	0.00	U1	All	OK		
3.000	1.40		-35.30	0.00	U1	All	OK	1.20	30.37	4.62	U1	All	OK		
4.000	1.20		-30.37	0.00	U1	All	OK	1.20	30.37	12.31	U1	All	OK		
5.167	1.20		-30.37	0.00	U1	All	OK	1.20	30.37	19.23	U1	All	OK		
6.167	0.00		0.00	0.00	U1	All	OK	1.20	30.37	23.40	U1	All	OK		
6.500	0.00		0.00	0.00	U1	All	OK	1.20	30.37	24.42	U1	All	OK		
8.129	0.00		0.00	0.00	U1	All	OK	1.20	30.37	26.87	U1	All	OK		
9.000	0.00		0.00	0.00	U1	All	OK	1.20	30.37	26.40	U1	All	OK		
11.500	0.00		0.00	0.00	U1	All	OK	1.20	30.37	18.24	U1	All	OK		
11.833	0.00		0.00	0.00	U1	All	OK	1.20	30.37	16.40	U1	All	OK		
12.833	1.20		-30.37	0.00	U1	All	OK	1.20	30.37	9.76	U1	All	OK		
14.000	1.20		-30.37	-0.05	U1	All	OK	1.20	30.37	0.00	U1	All	OK		
15.000	2.20	-54.64	-13.33	U1	All	OK	1.20	30.37	0.00	U1	All	OK			
17.333	2.20	-54.64	-50.21	U1	All	OK	1.20	30.37	0.00	U1	All	OK			
17.778	2.20	-54.64	-58.08	U1	All	---	1.20	30.37	0.00	U1	All	---			
18.000	2.20	-54.64	-62.11	U1	All	---	1.20	30.37	0.00	U1	All	---			
Middle	0.000	1.20	-30.37	0.47	U1	All	---	1.20	30.37	0.00	U1	All	---		
	0.667	1.20	-30.37	-0.00	U1	All	OK	1.20	30.37	0.00	U1	All	OK		
	1.662	1.20	-30.37	-0.20	U1	All	OK	1.20	30.37	0.00	U1	All	OK		
	3.333	1.20	-30.37	0.00	U1	All	OK	1.20	30.37	4.91	U1	All	OK		
	4.333	0.00	0.00	0.00	U1	All	OK	1.20	30.37	9.67	U1	All	OK		
	6.500	0.00	0.00	0.00	U1	All	OK	1.20	30.37	16.28	U1	All	OK		
	8.129	0.00	0.00	0.00	U1	All	OK	1.20	30.37	17.91	U1	All	OK		
	9.000	0.00	0.00	0.00	U1	All	OK	1.20	30.37	17.60	U1	All	OK		
	11.500	0.00	0.00	0.00	U1	All	OK	1.20	30.37	12.16	U1	All	OK		
	12.809	0.00	0.00	0.00	U1	All	OK	1.20	30.37	6.63	U1	All	OK		

	13.809	1.20	-30.37	0.00	U1 All OK	1.20	30.37	1.15	U1 All OK
	17.333	1.20	-30.37	-16.74	U1 All OK	1.20	30.37	0.00	U1 All OK
	18.000	1.20	-30.37	-21.82	U1 All ---	1.20	30.37	0.00	U1 All ---
3 Column	0.000	2.20	-54.64	-57.18	U1 All ---	1.20	30.37	0.00	U1 All ---
	0.667	2.20	-54.64	-45.47	U1 All OK	1.20	30.37	0.00	U1 All OK
	3.000	2.20	-54.64	-11.60	U1 All OK	1.20	30.37	0.00	U1 All OK
	4.000	1.20	-30.37	-0.45	U1 All OK	1.20	30.37	0.00	U1 All OK
	5.167	1.20	-30.37	0.00	U1 All OK	1.20	30.37	8.00	U1 All OK
	6.167	0.00	0.00	0.00	U1 All OK	1.20	30.37	13.40	U1 All OK
	6.500	0.00	0.00	0.00	U1 All OK	1.20	30.37	14.84	U1 All OK
	9.000	0.00	0.00	0.00	U1 All OK	1.20	30.37	19.90	U1 All OK
	9.124	0.00	0.00	0.00	U1 All OK	1.20	30.37	19.90	U1 All OK
	11.500	0.00	0.00	0.00	U1 All OK	1.20	30.37	14.84	U1 All OK
	11.833	0.00	0.00	0.00	U1 All OK	1.20	30.37	13.40	U1 All OK
	12.833	1.20	-30.37	0.00	U1 All OK	1.20	30.37	8.00	U1 All OK
	14.000	1.20	-30.37	-0.45	U1 All OK	1.20	30.37	0.00	U1 All OK
	15.000	2.20	-54.64	-11.60	U1 All OK	1.20	30.37	0.00	U1 All OK
	17.333	2.20	-54.64	-45.47	U1 All OK	1.20	30.37	0.00	U1 All OK
	18.000	2.20	-54.64	-57.18	U1 All ---	1.20	30.37	0.00	U1 All ---
Middle	0.000	1.20	-30.37	-19.06	U1 All ---	1.20	30.37	0.00	U1 All ---
	0.667	1.20	-30.37	-15.16	U1 All OK	1.20	30.37	0.00	U1 All OK
	4.191	1.20	-30.37	0.00	U1 All OK	1.20	30.37	0.77	U1 All OK
	5.191	0.00	0.00	0.00	U1 All OK	1.20	30.37	5.43	U1 All OK
	6.500	0.00	0.00	0.00	U1 All OK	1.20	30.37	9.89	U1 All OK
	9.000	0.00	0.00	0.00	U1 All OK	1.20	30.37	13.27	U1 All OK
	9.124	0.00	0.00	0.00	U1 All OK	1.20	30.37	13.27	U1 All OK
	11.500	0.00	0.00	0.00	U1 All OK	1.20	30.37	9.89	U1 All OK
	12.809	0.00	0.00	0.00	U1 All OK	1.20	30.37	5.43	U1 All OK
	13.809	1.20	-30.37	0.00	U1 All OK	1.20	30.37	0.77	U1 All OK
	17.333	1.20	-30.37	-15.16	U1 All OK	1.20	30.37	0.00	U1 All OK
	18.000	1.20	-30.37	-19.06	U1 All ---	1.20	30.37	0.00	U1 All ---
4 Column	0.000	2.20	-54.64	-62.11	U1 All ---	1.20	30.37	0.00	U1 All ---
	0.222	2.20	-54.64	-58.08	U1 All ---	1.20	30.37	0.00	U1 All ---
	0.667	2.20	-54.64	-50.22	U1 All OK	1.20	30.37	0.00	U1 All OK
	3.000	2.20	-54.64	-13.34	U1 All OK	1.20	30.37	0.00	U1 All OK
	4.000	1.20	-30.37	-0.06	U1 All OK	1.20	30.37	0.00	U1 All OK
	5.167	1.20	-30.37	0.00	U1 All OK	1.20	30.37	9.76	U1 All OK
	6.167	0.00	0.00	0.00	U1 All OK	1.20	30.37	16.40	U1 All OK
	6.500	0.00	0.00	0.00	U1 All OK	1.20	30.37	18.24	U1 All OK
	9.000	0.00	0.00	0.00	U1 All OK	1.20	30.37	26.40	U1 All OK
	9.871	0.00	0.00	0.00	U1 All OK	1.20	30.37	26.87	U1 All OK
	11.500	0.00	0.00	0.00	U1 All OK	1.20	30.37	24.42	U1 All OK
	11.833	0.00	0.00	0.00	U1 All OK	1.20	30.37	23.40	U1 All OK
	12.833	1.20	-30.37	0.00	U1 All OK	1.20	30.37	19.23	U1 All OK
	14.000	1.20	-30.37	0.00	U1 All OK	1.20	30.37	12.31	U1 All OK
	15.000	1.40	-35.30	0.00	U1 All OK	1.20	30.37	4.62	U1 All OK
	17.333	1.40	-35.30	-32.66	U1 All OK	1.20	30.37	0.00	U1 All OK
	17.556	1.40	-35.30	-37.39	U1 All ---	1.20	30.37	0.00	U1 All ---
	18.000	1.40	-35.30	-47.36	U1 All ---	1.20	30.37	0.00	U1 All ---
Middle	0.000	1.20	-30.37	-21.82	U1 All ---	1.20	30.37	0.00	U1 All ---
	0.667	1.20	-30.37	-16.74	U1 All OK	1.20	30.37	0.00	U1 All OK
	4.191	1.20	-30.37	0.00	U1 All OK	1.20	30.37	1.14	U1 All OK
	5.191	0.00	0.00	0.00	U1 All OK	1.20	30.37	6.62	U1 All OK
	6.500	0.00	0.00	0.00	U1 All OK	1.20	30.37	12.16	U1 All OK
	9.000	0.00	0.00	0.00	U1 All OK	1.20	30.37	17.60	U1 All OK
	9.871	0.00	0.00	0.00	U1 All OK	1.20	30.37	17.91	U1 All OK
	11.500	0.00	0.00	0.00	U1 All OK	1.20	30.37	16.28	U1 All OK
	13.667	0.00	0.00	0.00	U1 All OK	1.20	30.37	9.67	U1 All OK
	14.667	1.20	-30.37	0.00	U1 All OK	1.20	30.37	4.91	U1 All OK
	16.338	1.20	-30.37	-0.20	U1 All OK	1.20	30.37	0.00	U1 All OK
	17.333	1.20	-30.37	-0.00	U1 All OK	1.20	30.37	0.00	U1 All OK
	18.000	1.20	-30.37	0.47	U1 All ---	1.20	30.37	0.00	U1 All ---
5 Column	0.000	1.40	-35.30	-0.60	U1 All ---	0.00	0.00	0.00	U1 All ---
	0.117	1.40	-35.30	-0.43	U1 All OK	0.00	0.00	0.00	U1 All OK
	0.309	1.40	-35.30	-0.19	U1 All OK	0.00	0.00	0.00	U1 All OK
	0.333	1.40	-35.30	-0.17	U1 All OK	0.00	0.00	0.00	U1 All OK
	0.474	1.40	-35.30	-0.06	U1 All OK	0.00	0.00	0.00	U1 All OK
	0.667	1.40	-35.30	0.00	U1 All OK	0.00	0.00	0.00	U1 All OK
Middle	0.000	1.20	-30.37	-0.00	U1 All ---	0.00	0.00	0.00	U1 All ---
	0.117	1.20	-30.37	-0.00	U1 All OK	0.00	0.00	0.00	U1 All OK
	0.309	1.20	-30.37	-0.00	U1 All OK	0.00	0.00	0.00	U1 All OK
	0.333	1.20	-30.37	-0.00	U1 All OK	0.00	0.00	0.00	U1 All OK
	0.474	1.20	-30.37	-0.00	U1 All OK	0.00	0.00	0.00	U1 All OK
	0.667	1.20	-30.37	0.00	U1 All OK	0.00	0.00	0.00	U1 All OK

Slab Shear Capacity

=====

Units: b, d (in), Xu (ft), PhiVc, Vu(kip)

Span	b	d	Vratio	PhiVc	Vu	Xu
1	168.00	5.75	1.000	91.64	0.00	0.00
2	168.00	5.75	1.000	91.64	23.28	16.85
3	168.00	5.75	1.000	91.64	21.22	1.15
4	168.00	5.75	1.000	91.64	23.28	1.15



5 168.00 5.75 1.000 91.64 0.00 0.00

Flexural Transfer of Negative Unbalanced Moment at Supports

=====

Units: Width (in), Munb (k-ft), As (in^2)

Supp	Width	Width-c	d	Munb	Comb	Pat	GammaF	AsReq	AsProv	Add Bars
1	37.00	37.00	5.75	46.30	U1	All	0.617	1.159	0.617	3-#4
2	37.00	37.00	5.75	7.69	U1	All	0.600	0.180	0.969	---
3	37.00	37.00	5.75	7.69	U1	All	0.600	0.180	0.969	---
4	37.00	37.00	5.75	46.30	U1	All	0.617	1.159	0.617	3-#4

Punching Shear Around Columns

=====

Critical Section Properties

Units: b1, b2, b0, davg, CG, c(left), c(right) (in), Ac (in^2), Jc (in^4)

Supp	Type	b1	b2	b0	davg	CG	c(left)	c(right)	Ac	Jc
1	Rect	18.88	21.75	59.50	5.75	4.89	12.89	5.99	342.13	14110
2	Rect	21.75	21.75	87.00	5.75	0.00	10.88	10.88	500.25	40131
3	Rect	21.75	21.75	87.00	5.75	0.00	10.88	10.88	500.25	40131
4	Rect	18.88	21.75	59.50	5.75	-4.89	5.99	12.89	342.13	14110

Punching Shear Results

Units: Vu (kip), Munb (k-ft), vu (psi), Phi\*vc (psi)

Supp	Vu	vu	Munb	Comb	Pat	GammaV	vu	Phi*vc
1	23.51	68.7	36.72	U1	All	0.383	140.4	189.7
2	50.06	100.1	-7.69	U1	All	0.400	110.1	189.7
3	50.06	100.1	7.69	U1	All	0.400	110.1	189.7
4	23.51	68.7	-36.72	U1	All	0.383	140.4	189.7

Material Takeoff

=====

Reinforcement in the Direction of Analysis

Top Bars:	336.6 lb	<=>	6.08 lb/ft	<=>	0.435 lb/ft^2
Bottom Bars:	432.9 lb	<=>	7.82 lb/ft	<=>	0.559 lb/ft^2
Stirrups:	0.0 lb	<=>	0.00 lb/ft	<=>	0.000 lb/ft^2
Total Steel:	769.5 lb	<=>	13.91 lb/ft	<=>	0.993 lb/ft^2
Concrete:	451.9 ft^3	<=>	8.17 ft^3/ft	<=>	0.583 ft^3/ft^2

```

                oooooo   o
                oo   oo   oo
    oooooo   oooooo   oo   oo   oooooo   oo
    oo   o   oo   oo   oo   oo   o   oo   oo
    oo   oo   oo   ooo   oo   oooooo   oooooo
    oooooo   oo   oo   ooo   oo   oo   oo   oo   oo
    oo   oo   oooooo   oo   oo   oo   oo   oo   oo
    o   oo   oo   oo   oo   oo   o   oo   oo   oo
    oooooo   oo   oooooo   ooo   oooooo   o   oooooo   (TM)
    
```

=====  
 spSlab v5.00 (TM)  
 A Computer Program for Analysis, Design, and Investigation of  
 Reinforced Concrete Beams, One-way and Two-way Slab Systems  
 Copyright © 2003-2015, STRUCTUREPOINT, LLC  
 All rights reserved  
 =====

Licensee stated above acknowledges that STRUCTUREPOINT (SP) is not and cannot be responsible for either the accuracy or adequacy of the material supplied as input for processing by the spSlab computer program. Furthermore, STRUCTUREPOINT neither makes any warranty expressed nor implied with respect to the correctness of the output prepared by the spSlab program. Although STRUCTUREPOINT has endeavored to produce spSlab error free the program is not and cannot be certified infallible. The final and only responsibility for analysis, design and engineering documents is the licensee's. Accordingly, STRUCTUREPOINT disclaims all responsibility in contract, negligence or other tort for any analysis, design or engineering documents prepared in connection with the use of the spSlab program.

=====  
 [3] DEFLECTION RESULTS  
 =====

Section Properties

-----  
 Frame Section Properties  
 -----

Units: Ig, Icr (in^4), Mcr (k-ft)

Span Zone	M+ve			M-ve		
	Ig	Icr	Mcr	Ig	Icr	Mcr
1 Left	4802	0	54.23	4802	466	-54.23
Midspan	4802	0	54.23	4802	499	-54.23
Right	4802	0	54.23	4802	499	-54.23
2 Left	4802	466	54.23	4802	499	-54.23
Midspan	4802	466	54.23	4802	0	-54.23
Right	4802	466	54.23	4802	629	-54.23
3 Left	4802	466	54.23	4802	629	-54.23
Midspan	4802	466	54.23	4802	0	-54.23
Right	4802	466	54.23	4802	629	-54.23
4 Left	4802	466	54.23	4802	629	-54.23
Midspan	4802	466	54.23	4802	0	-54.23
Right	4802	466	54.23	4802	499	-54.23
5 Left	4802	0	54.23	4802	499	-54.23
Midspan	4802	0	54.23	4802	499	-54.23
Right	4802	0	54.23	4802	466	-54.23

NOTES: M+ve values are for positive moments (tension at bottom face).  
 M-ve values are for negative moments (tension at top face).

Frame Effective Section Properties

Units: Ie, Ie,avg (in^4), Mmax (k-ft)

Span Zone	Weight	Load Level					
		Dead		Sustained		Dead+Live	
		Mmax	Ie	Mmax	Ie	Mmax	Ie
1 Right	1.000	-0.33	4802	-0.33	4802	-0.46	4802
Span Avg	----	----	4802	----	4802	----	4802
2 Middle	0.850	24.94	4802	24.94	4802	34.23	4802
Right	0.150	-46.75	4802	-46.75	4802	-64.15	3151
Span Avg	----	----	4802	----	4802	----	4554
3 Left	0.150	-42.47	4802	-42.47	4802	-58.27	3994
Middle	0.700	18.47	4802	18.47	4802	25.35	4802
Right	0.150	-42.47	4802	-42.47	4802	-58.27	3994
Span Avg	----	----	4802	----	4802	----	4560
4 Left	0.150	-46.75	4802	-46.75	4802	-64.15	3151
Middle	0.850	24.94	4802	24.94	4802	34.23	4802
Span Avg	----	----	4802	----	4802	----	4554
5 Left	1.000	-0.33	4802	-0.33	4802	-0.46	4802
Span Avg	----	----	4802	----	4802	----	4802

Strip Section Properties at Midspan

Units: Ig (in<sup>4</sup>)

Span	Column Strip			Middle Strip		
	Ig	LDF	Ratio	Ig	LDF	Ratio
1	2401	0.800	1.600	2401	0.200	0.400
2	2401	0.738	1.475	2401	0.262	0.525
3	2401	0.675	1.350	2401	0.325	0.650
4	2401	0.738	1.475	2401	0.262	0.525
5	2401	0.800	1.600	2401	0.200	0.400

NOTES: Load distribution factor, LDL, averages moment distribution factors listed in [2] Design Results.  
 Ratio refers to proportion of strip to frame deflections under fix-end conditions.

Instantaneous Deflections

Extreme Instantaneous Frame Deflections and Corresponding Locations

Units: Def (in), Loc (ft)

Span	Direction	Value	Dead	Live		Total	Total	
				Sustained	Unsustained		Sustained	Dead+Live
1	Down	Def	---	---	---	---	---	---
		Loc	---	---	---	---	---	
	Up	Def	-0.004	---	-0.002	-0.002	-0.004	-0.006
2	Down	Def	0.055	---	0.023	0.023	0.055	0.078
		Loc	8.378	---	8.378	8.378	8.378	
	Up	Def	---	---	---	---	---	
3	Down	Def	0.032	---	0.014	0.014	0.032	0.046
		Loc	8.876	---	8.876	8.876	8.876	
	Up	Def	-0.000	---	-0.000	-0.000	-0.000	
4	Down	Def	0.055	---	0.023	0.023	0.055	0.078
		Loc	9.622	---	9.622	9.622	9.622	
	Up	Def	---	---	---	---	---	
5	Down	Def	---	---	---	---	---	
		Loc	---	---	---	---	---	
	Up	Def	-0.004	---	-0.002	-0.002	-0.004	-0.006
		Loc	0.667	---	0.667	0.667	0.667	

Extreme Instantaneous Column Strip Deflections and Corresponding Locations

Units: Def (in), Loc (ft)

Span	Direction	Value	Dead	Live		Total	Total	
				Sustained	Unsustained		Sustained	Dead+Live
1	Down	Def	---	---	---	---	---	---
		Loc	---	---	---	---	---	
	Up	Def	-0.004	---	-0.002	-0.002	-0.004	-0.006
2	Down	Def	0.072	---	0.031	0.031	0.072	0.103
		Loc	8.627	---	8.627	8.627	8.627	
	Up	Def	---	---	---	---	---	
3	Down	Def	0.045	---	0.019	0.019	0.045	0.064
		Loc	8.876	---	8.876	8.876	8.876	
	Up	Def	-0.000	---	-0.000	-0.000	-0.000	
4	Down	Def	0.222	---	0.222	0.222	0.222	0.222
		Loc	9.373	---	9.373	9.373	9.373	
	Up	Def	---	---	---	---	---	
5	Down	Def	---	---	---	---	---	
		Loc	---	---	---	---	---	
	Up	Def	-0.004	---	-0.002	-0.002	-0.004	-0.006
		Loc	0.667	---	0.667	0.667	0.667	

Extreme Instantaneous Middle Strip Deflections and Corresponding Locations

Units: Def (in), Loc (ft)

Span	Direction	Value	Dead	Live		Total	Total	
				Sustained	Unsustained		Sustained	Dead+Live
1	Down	Def	---	---	---	---	---	---
		Loc	---	---	---	---	---	
	Up	Def	-0.004	---	-0.002	-0.002	-0.004	-0.006
2	Down	Def	0.038	---	0.016	0.016	0.038	0.054
		Loc	7.881	---	8.129	8.129	7.881	
	Up	Def	---	---	---	---	---	
3	Down	Def	0.019	---	0.008	0.008	0.019	0.027
		Loc	8.876	---	8.876	8.876	8.876	
	Up	Def	-0.000	---	-0.000	-0.000	-0.000	
		Loc	0.667	---	0.667	0.667	0.667	

4	Down	Def	0.038	---	0.016	0.016	0.038	0.054
		Loc	9.871	---	9.871	9.871	9.871	9.871
	Up	Def	---	---	---	---	---	---
		Loc	---	---	---	---	---	---
5	Down	Def	---	---	---	---	---	---
		Loc	---	---	---	---	---	---
	Up	Def	-0.004	---	-0.002	-0.002	-0.004	-0.006
		Loc	0.667	---	0.667	0.667	0.667	0.667

Long-term Deflections

Long-term Column Strip Deflection Factors

Time dependant factor for sustained loads = 2.000

Units: Astop, Asbot (in<sup>2</sup>), b, d (in), Rho' (%), Lambda (-)

Span	Zone	M+ve					M-ve				
		Astop	b	d	Rho'	Lambda	Asbot	b	d	Rho'	Lambda
1	Right	----	----	----	0.000	2.000	----	----	----	0.000	2.000
2	Midspan	----	----	----	0.000	2.000	----	----	----	0.000	2.000
3	Midspan	----	----	----	0.000	2.000	----	----	----	0.000	2.000
4	Midspan	----	----	----	0.000	2.000	----	----	----	0.000	2.000
5	Left	----	----	----	0.000	2.000	----	----	----	0.000	2.000

NOTES: Deflection multiplier, Lambda, depends on moment sign at sustained load level and Rho' in given zone.  
 Rho' is assumed zero because Compression Reinforcement option is NOT selected in Solve Options.

Long-term Middle Strip Deflection Factors

Time dependant factor for sustained loads = 2.000

Units: Astop, Asbot (in<sup>2</sup>), b, d (in), Rho' (%), Lambda (-)

Span	Zone	M+ve					M-ve				
		Astop	b	d	Rho'	Lambda	Asbot	b	d	Rho'	Lambda
1	Right	----	----	----	0.000	2.000	----	----	----	0.000	2.000
2	Midspan	----	----	----	0.000	2.000	----	----	----	0.000	2.000
3	Midspan	----	----	----	0.000	2.000	----	----	----	0.000	2.000
4	Midspan	----	----	----	0.000	2.000	----	----	----	0.000	2.000
5	Left	----	----	----	0.000	2.000	----	----	----	0.000	2.000

NOTES: Deflection multiplier, Lambda, depends on moment sign at sustained load level and Rho' in given zone.  
 Rho' is assumed zero because Compression Reinforcement option is NOT selected in Solve Options.

Extreme Long-term Column Strip Deflections and Corresponding Locations

Units: D (in), x (ft)

Span	Direction	Value	cs	cs+lu	cs+l	Total
1	Down	Def	---	---	---	---
		Loc	---	---	---	---
	Up	Def	-0.009	-0.011	-0.011	-0.015
		Loc	0.000	0.000	0.000	0.000
2	Down	Def	0.145	0.176	0.176	0.248
		Loc	8.627	8.627	8.627	8.627
	Up	Def	---	---	---	---
		Loc	---	---	---	---
3	Down	Def	0.089	0.109	0.109	0.153
		Loc	8.876	8.876	8.876	8.876
	Up	Def	-0.000	-0.000	-0.000	-0.000
		Loc	0.222	0.222	0.222	0.222
4	Down	Def	0.145	0.176	0.176	0.248
		Loc	9.373	9.373	9.373	9.373
	Up	Def	---	---	---	---
		Loc	---	---	---	---
5	Down	Def	---	---	---	---
		Loc	---	---	---	---
	Up	Def	-0.009	-0.011	-0.011	-0.015
		Loc	0.667	0.667	0.667	0.667

NOTES: Incremental deflections due to creep and shrinkage (cs) based on sustained load level values.  
 Incremental deflections after partitions are installed can be estimated by deflections due to:  
 - creep and shrinkage plus unsustained live load (cs+lu), if live load applied before partitions,  
 - creep and shrinkage plus live load (cs+l), if live load applied after partitions.  
 Total deflections consist of dead, live, and creep and shrinkage deflections.

Extreme Long-term Middle Strip Deflections and Corresponding Locations

Units: D (in), x (ft)

Span	Direction	Value	cs	cs+lu	cs+l	Total
1	Down	Def	---	---	---	---
		Loc	---	---	---	---
	Up	Def	-0.009	-0.011	-0.011	-0.015
		Loc	0.000	0.000	0.000	0.000
2	Down	Def	0.076	0.091	0.091	0.129
		Loc	8.129	8.129	8.129	8.129
	Up	Def	---	---	---	---

		Loc	---	---	---	---
3	Down	Def	0.038	0.046	0.046	0.065
		Loc	8.876	8.876	8.876	8.876
	Up	Def	-0.001	-0.001	-0.001	-0.001
		Loc	0.667	0.667	0.667	0.667
4	Down	Def	0.076	0.091	0.091	0.129
		Loc	9.871	9.871	9.871	9.871
	Up	Def	---	---	---	---
		Loc	---	---	---	---
5	Down	Def	---	---	---	---
		Loc	---	---	---	---
	Up	Def	-0.009	-0.011	-0.011	-0.015
		Loc	0.667	0.667	0.667	0.667

NOTES: Incremental deflections due to creep and shrinkage (cs) based on sustained load level values.  
 Incremental deflections after partitions are installed can be estimated by deflections due to:  
 - creep and shrinkage plus unsustained live load (cs+lu), if live load applied before partitions,  
 - creep and shrinkage plus live load (cs+l), if live load applied after partitions.  
 Total deflections consist of dead, live, and creep and shrinkage deflections.

**7. Summary and Comparison of Two-Way Slab Design Results**

<b>Table 12 - Comparison of Moments obtained from Hand (EFM) and spSlab Solution</b>			
		<b>Hand (EFM)</b>	<b>spSlab</b>
<b>Exterior Span</b>			
Column Strip	Exterior Negative*	32.20	32.66
	Positive	26.50	26.87
	Interior Negative*	50.30	50.21
Middle Strip	Exterior Negative*	0.00	0.20
	Positive	17.70	17.91
	Interior Negative*	16.70	16.74
<b>Interior Span</b>			
Column Strip	Interior Negative*	45.60	45.47
	Positive	19.90	19.90
Middle Strip	Interior Negative*	15.20	15.16
	Positive	13.20	13.27

\* negative moments are taken at the faces of supports

<b>Table 13 - Comparison of Reinforcement Results with Hand and spSlab Solution</b>							
Span Location		Reinforcement Provided for Flexure		Additional Reinforcement Provided for Unbalanced Moment Transfer*		Total Reinforcement Provided	
		Hand	spSlab	Hand	spSlab	Hand	spSlab
<b>Exterior Span</b>							
Column Strip	Exterior Negative	7-#4	7-#4	3-#4	3-#4	10-#4	10-#4
	Positive	6-#4	6-#4	n/a	n/a	6-#4	6-#4
	Interior Negative	11-#4	11-#4	---	---	11-#4	11-#4
Middle Strip	Exterior Negative	6-#4	6-#4	n/a	n/a	6-#4	6-#4
	Positive	6-#4	6-#4	n/a	n/a	6-#4	6-#4
	Interior Negative	6-#4	6-#4	n/a	n/a	6-#4	6-#4
<b>Interior Span</b>							
Column Strip	Positive	6-#4	6-#4	n/a	n/a	6-#4	6-#4
Middle Strip	Positive	6-#4	6-#4	n/a	n/a	6-#4	6-#4

\*In the EFM, the unbalanced moment ( $M_{sc}$ ,  $M_{unb}$ ) at the support centerline is used to determine the value of the additional reinforcement as compared with DDM using the moments at the face of support.

**Table 14 - Comparison of One-Way (Beam Action) Shear Check Results Using Hand and spSlab Solution**

Span	$V_u$ , kips		$x_u^*$ , in.		$\phi V_c$ , kips	
	Hand	spSlab	Hand	spSlab	Hand	spSlab
Exterior	23.3	23.3	1.15	1.15	91.64	91.64
Interior	21.2	21.2	16.85	16.85	91.64	91.64

\*  $x_u$  calculated from the centerline of the left column for each span

**Table 15 - Comparison of Two-Way (Punching) Shear Check Results Using Hand and spSlab Solution**

Support	$b_1$ , in.		$b_2$ , in.		$b_o$ , in.		$A_c$ , in. <sup>2</sup>		$V_u$ , kips		$v_u$ , psi	
	Hand	spSlab	Hand	spSlab	Hand	spSlab	Hand	spSlab	Hand	spSlab	Hand	spSlab
Exterior	18.88	18.88	21.75	21.75	59.5	59.5	342.00	342.13	21.65	22.79	63.3	66.6
Interior	21.75	21.75	21.75	21.75	87	87	500.00	500.25	50.07	50.07	100.1	100.1

Support	$C_{AB}$ , in.		$J_c$ , in. <sup>4</sup>		$\gamma_v$		$M_{umb}$ , kips-ft		$v_u$ , psi		$\phi v_c$ , psi	
	Hand	spSlab	Hand	spSlab	Hand	spSlab	Hand	spSlab	Hand	spSlab	Hand	spSlab
Exterior	5.99	5.99	14109	14110	0.383	0.383	37.8	37.2	137.0	139.2	189.7	189.7
Interior	10.88	10.88	40131	40131	0.400	0.400	-7.8	-7.7	110.2	110.1	189.7	189.7

**Table 16 - Comparison of Immediate Deflection Results Using Hand and spSlab Solution (in.)**

Column Strip									
Span	D		D+LL <sub>sus</sub>		D+LL <sub>full</sub>		LL		
	Hand	spSlab	Hand	spSlab	Hand	spSlab	Hand	spSlab	
Exterior	0.076	0.072	0.076	0.072	0.110	0.103	0.034	0.031	
Interior	0.047	0.045	0.047	0.045	0.068	0.064	0.021	0.019	

Middle Strip									
Span	D		D+LL <sub>sus</sub>		D+LL <sub>full</sub>		LL		
	Hand	spSlab	Hand	spSlab	Hand	spSlab	Hand	spSlab	
Exterior	0.039	0.038	0.039	0.038	0.056	0.054	0.017	0.016	
Interior	0.020	0.019	0.020	0.019	0.029	0.027	0.009	0.008	

**Table 17 - Comparison of Time-Dependent Deflection Results Using Hand and spSlab Solution**

Column Strip						
Span	$\lambda_A$		$\Delta_{cs}$ , in.		$\Delta_{total}$ , in.	
	Hand	spSlab	Hand	spSlab	Hand	spSlab
Exterior	2.0	2.0	0.152	0.145	0.261	0.248
Interior	2.0	2.0	0.095	0.089	0.162	0.153

Middle Strip						
Span	$\lambda_A$		$\Delta_{cs}$ , in.		$\Delta_{total}$ , in.	
	Hand	spSlab	Hand	spSlab	Hand	spSlab
Exterior	2.0	2.0	0.078	0.076	0.134	0.129

Interior	2.0	2.0	0.041	0.038	0.069	0.065
----------	-----	-----	-------	-------	-------	-------

In all of the hand calculations illustrated above, the results are in close or exact agreement with the automated analysis and design results obtained from the spSlab model. Excerpts of spSlab graphical and text output are given below for illustration.

## 8. Comparison of Two-Way Slab Analysis and Design Methods

A slab system can be analyzed and designed by any procedure satisfying equilibrium and geometric compatibility. Three established methods are widely used. The requirements for two of them are described in detail in ACI 318-14 Chapter 8 (8.2.1).

Direct Design Method (DDM) is an approximate method and is applicable to flat plate concrete floor systems that meet the stringent requirements of ACI 318-14 (8.10.2). In many projects, however, these requirements limit the usability of the Direct Design Method significantly.

The Equivalent Frame Method (EFM) does not have the limitations of Direct Design Method. It requires more accurate analysis methods that, depending on the size and geometry can prove to be long, tedious, and time-consuming.

StructurePoint's [spSlab](#) software program solution utilizes the Equivalent Frame Method to automate the process providing considerable time-savings in the analysis and design of two-way slab systems as compared to hand solutions using DDM or EFM.

Finite Element Method (FEM) is another method for analyzing reinforced concrete slabs, particularly useful for irregular slab systems with variable thicknesses, openings, and other features not permissible in DDM or EFM. Many reputable commercial FEM analysis software packages are available on the market today such as [spMats](#). Using FEM requires critical understanding of the relationship between the actual behavior of the structure and the numerical simulation since this method is an approximate numerical method. The method is based on several assumptions and the operator has a great deal of decisions to make while setting up the model and applying loads and boundary conditions. The results obtained from FEM models should be verified to confirm their suitability for design and detailing of concrete structures.

The following table shows a general comparison between the DDM, EFM and FEM. This table covers general limitations, drawbacks, advantages, and cost-time efficiency of each method where it helps the engineer in deciding which method to use based on the project complexity, schedule, and budget.



Applicable ACI 318-14 Provision	Limitations/Applicability	Concrete Slab Analysis Method		
		DDM (Hand)	EFM (Hand//spSlab)	FEM (spMats)
8.10.2.1	Minimum of three continuous spans in each direction	<input checked="" type="checkbox"/>		
8.10.2.2	Successive span lengths measured center-to-center of supports in each direction shall not differ by more than one-third the longer span	<input checked="" type="checkbox"/>		
8.10.2.3	Panels shall be rectangular, with ratio of longer to shorter panel dimensions, measured center-to-center supports, not exceed 2.	<input checked="" type="checkbox"/>	<input checked="" type="checkbox"/>	
8.10.2.4	Column offset shall not exceed 10% of the span in direction of offset from either axis between centerlines of successive columns	<input checked="" type="checkbox"/>		
8.10.2.5	All loads shall be due to gravity only	<input checked="" type="checkbox"/>		
8.10.2.5	All loads shall be uniformly distributed over an entire panel ( $q_u$ )	<input checked="" type="checkbox"/>		
8.10.2.6	Unfactored live load shall not exceed two times the unfactored dead load	<input checked="" type="checkbox"/>		
8.10.2.7	For a panel with beams between supports on all sides, slab-to-beam stiffness ratio shall be satisfied for beams in the two perpendicular directions.	<input checked="" type="checkbox"/>		
8.7.4.2	Structural integrity steel detailing	<input checked="" type="checkbox"/>	<input checked="" type="checkbox"/>	<input checked="" type="checkbox"/>
8.5.4	Openings in slab systems	<input checked="" type="checkbox"/>	<input checked="" type="checkbox"/>	<input checked="" type="checkbox"/>
8.2.2	Concentrated loads	Not permitted	<input checked="" type="checkbox"/>	<input checked="" type="checkbox"/>
8.11.1.2	Live load arrangement (Load Patterning)	Not required	Required	Engineering judgment required based on modeling technique
R8.10.4.5*	Reinforcement for unbalanced slab moment transfer to column ( $M_{sc}$ )	Moments @ support face	Moments @ support centerline	Engineering judgment required based on modeling technique
	Irregularities (i.e. variable thickness, non-prismatic, partial bands, mixed systems, support arrangement, etc.)	Not permitted	Engineering judgment required	Engineering judgment required
Complexity		Low	Average	Complex to very complex
Design time/costs		Fast	Limited	Unpredictable/Costly
Design Economy		Conservative (see detailed comparison with spSlab output)	Somewhat conservative	Unknown - highly dependent on modeling assumptions: 1. Linear vs. non-linear 2. Isotropic vs non-isotropic 3. Plate element choice 4. Mesh size and aspect ratio 5. Design & detailing features
General (Drawbacks)		Very limited applications	Limited geometry	Limited guidance non-standard application (user dependent). Required significant engineering judgment
General (Advantages)		Very limited analysis is required	Detailed analysis is required or via software (e.g. spSlab)	Unlimited applicability to handle complex situations permissible by the features of the software used (e.g. spMats)
* The unbalanced slab moment transferred to the column $M_{sc}$ ( $M_{unb}$ ) is the difference in slab moment on either side of a column at a specific joint. In DDM only moments at the face of the support are calculated and are also used to obtain $M_{sc}$ ( $M_{unb}$ ). In EFM where a frame analysis is used, moments at the column center line are used to obtain $M_{sc}$ ( $M_{unb}$ ).				