

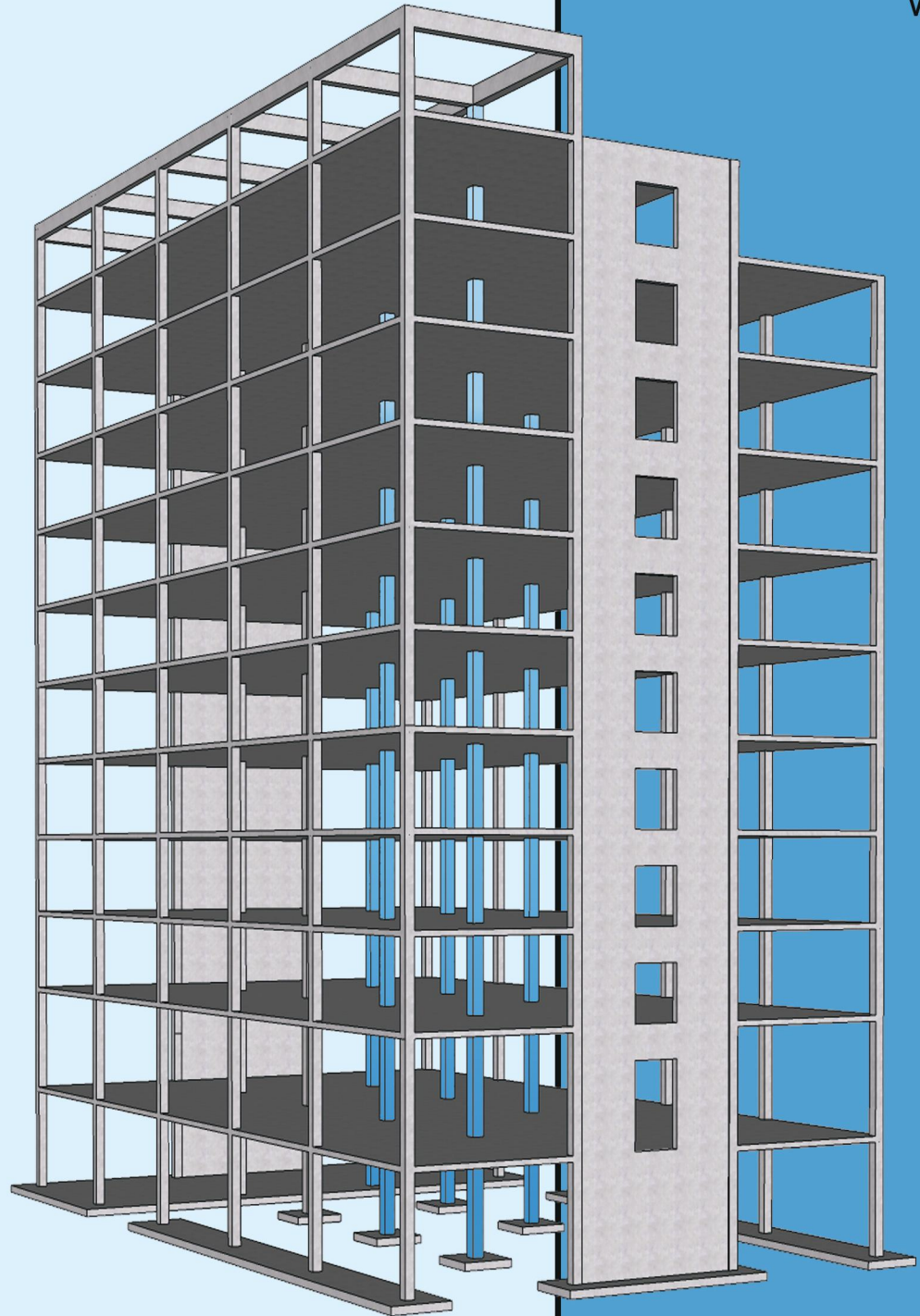

v10.20

# Technical Manual





## Version 10.20

This Computer program (including software design, programming structure, graphics, manual, and on-line help) was created and published by STRUCTUREPOINT, formerly the Engineering Software Group of the Portland Cement Association (PCA), for engineering design and investigation of reinforced concrete sections subject to axial and flexural loads.

While STRUCTUREPOINT has taken every precaution to utilize the existing state-of-the-art and to assure the correctness of the analytical solution techniques used in this program, the responsibilities for modeling the structure, inputting data, applying engineering judgment to evaluate the output, and implementing engineering drawings remain with the structural engineer of record. Accordingly, STRUCTUREPOINT does and must disclaim any and all responsibility for defects or failures of structures in connection with which this program is used.

Neither this manual nor any part of it may be reproduced, edited, or altered by any means electronic or mechanical or by any information storage and retrieval system, without the written permission of STRUCTUREPOINT LLC.

All products, corporate names, trademarks, service marks, and trade names referenced in this material are the property of their respective owners and are used only for identification explanation without intent to infringe. spColumn<sup>®</sup> is a registered trademark of STRUCTUREPOINT LLC.

Copyright © 1988 – 2025, STRUCTUREPOINT LLC All Rights Reserved.

## Chapter 1: INTRODUCTION

1.1. Program Features.....	7
1.2. Program Capacity .....	8
1.3. System Installation Requirements .....	9
1.4. Terms & Conventions .....	10

## Chapter 2: SOLUTION METHODS

2.1. Introduction .....	11
2.1.1. Column Systems .....	12
2.1.2. Coordinate Systems .....	17
2.2. Codes and Standards Provisions.....	20
2.2.1. Code Checks .....	20
2.2.2. Geometry Checks.....	20
2.2.3. Definitions and Assumptions.....	21
2.3. Analysis Methods .....	34
2.3.1. Section Investigation Mode .....	34
2.3.1.1. Loading Options .....	34
2.3.1.2. Interaction Diagram Options .....	36
2.3.2. Section Design Mode.....	38
2.3.2.1. Design Criteria .....	38
2.3.2.2. Design Procedure .....	38
2.3.3. Moment Magnification at Ends of Compression Member .....	40
2.3.4. Moment Magnification along Length of Compression Member .....	45
2.3.5. Moments Magnification Ratio .....	52
2.4. Design Methods.....	54
2.4.1. Moment Capacity Method .....	54
2.4.2. Critical Capacity Method.....	55
2.5. Detailing Provisions .....	57
2.5.1. Lap Splice Requirements .....	58
2.6. Special Topics .....	61

2.6.1. High Strength Reinforcing Bars (HSRB) .....	61
2.6.2. Effective Flexural Stiffness.....	62
2.6.3. CSA Minimum Moment Provisions .....	63
2.6.4. Bundled Reinforcement Bars.....	64
2.7. References .....	66

### Chapter 3: PROGRAM INTERFACE

3.1. Start Screen.....	68
3.2. Main Program Window .....	70
3.3. Tables Window.....	73
3.4. Reporter Window .....	77
3.5. Print/Export Window .....	83

### Chapter 4: MODELING METHODS

4.1. Model Creation Concepts.....	86
4.1.1. Physical Modeling Terminology.....	87
4.1.2. Structural Member .....	88
4.1.3. Section.....	89
4.1.4. Input Preparation.....	93
4.1.5. Modeling Considerations.....	94
4.2. Model Editing Concepts.....	96

### Chapter 5: MODEL DEVELOPMENT

5.1. Model Creation.....	100
5.2. Opening Existing Models .....	102
5.3. Creating New Models.....	103
5.3.1. Project Information .....	103
5.3.2. Generating Definitions.....	104
5.3.2.1. Properties.....	105
5.3.2.2. Load Case/Combo .....	109

5.3.3. Creating Section.....	110
5.3.4. Generating Loads.....	112
5.3.4.1. Loads.....	112
5.3.4.2. Modes (No Loads).....	114
5.3.5. Slenderness .....	115
5.3.5.1. Design Column (X-Axis and Y-Axis).....	115
5.3.5.2. Columns Above/Below .....	117
5.3.5.3. X – Beams and Y – Beams.....	118
5.3.5.4. Slenderness Factor.....	120
5.4. Modeling with Templates.....	121
5.4.1. Utilizing Templates.....	121
5.5. Utilizing Predefined Examples.....	124
5.6. Importing Model Data.....	125
5.6.1. Importing Section from Text .....	126
5.6.2. Importing Section from DXF.....	127
5.6.3. Importing Loads from Text.....	128
5.6.4. Importing Loads from ETABS .....	129
5.7. Exporting Model Data.....	134
5.7.1. Exporting Section Data .....	134
5.7.2. Exporting Loads Data .....	134
5.7.3. Exporting Diagrams.....	135

## Chapter 6: MODEL SOLUTION

6.1. Running from program.....	137
6.2. Running with Batch Processor .....	140
6.3. Running from command prompt.....	142

## Chapter 7: MODEL OUTPUT

7.1. Tabular Output .....	145
7.1.1. Input.....	145

7.1.2. Results.....	147
7.2. Graphical Output .....	148
7.2.1. Diagram Types.....	150
7.2.2. Viewing Aids .....	156
7.3. Output Settings .....	159
7.3.1. Settings – Tabular Results .....	160
7.3.2. Settings – 2D Diagram.....	161
7.3.3. Settings – 3D Diagram.....	164

## Chapter: APPENDIX

A.1. Default Load Case and Combination Factors.....	167
A.2. Import File Formats.....	172
A.2.1. Service Loads Data .....	173
A.2.2. Factored Loads Data .....	174
A.2.3. Reinforcement Data .....	175
A.2.4. Geometry Data.....	176
A.3. spColumn Text Input (CTI) file format.....	178
A.4. Exporting XML Model Data Files from ETABS .....	203
A.5. Conversion Factors – English to SI.....	205
A.6. Conversion Factors – SI to English.....	206
A.7. Material Strength Value Limits.....	207
A.8. Technical Resources.....	208
A.9. Contact Information .....	209
A.10. Technical Manual Revision History .....	210

CHAPTER

1

# INTRODUCTION

---

spColumn is a structural engineering software program for the design and investigation of reinforced concrete sections subject to axial and flexural loads. The section can be rectangular, round or irregular, with any reinforcement layout or pattern. Slenderness effects can be considered.

The program offers investigation of irregularly shaped, reinforced concrete column sections that may contain openings or boundary elements. Widely used for design of shear walls, elevator shafts, building cores, bridge piers as well as typical framing elements in buildings, spColumn can investigate sections that are impossible to find on design charts or do by hand calculations. You can obtain the P-M interaction diagrams from both uniaxial and biaxial runs, as well as the  $M_x$ - $M_y$  moment contour plots from biaxial runs for even the most irregular column and shear wall sections. Slenderness effects producing magnified moments may be included in the section design or investigation.

## 1.1. Program Features

---

- Code support for ACI 318-19, ACI 318-14, ACI 318-11, ACI 318-08, ACI 318-05, ACI 318-02
- Code support for CSA A23.3-19, CSA A23.3-14, CSA A23.3-04, and CSA A23.3-94
- English and SI units
- Design and investigation run options
- Uniaxial or biaxial flexure combined with axial load
- Rectangular, circular, and irregular section geometry
- Non-slender and sway or nonsway slender columns
- Complete P-M and  $M_x$ - $M_y$  interaction diagrams
- Customizable view of interaction diagrams and failure surfaces in multi viewports
- Superposition of interaction diagram of multiple sections
- Factored, unfactored, axial, and control points loading
- Binary (COLX) and text (CTI) input file formats
- Graphical input for irregular sections
- Imports geometry, reinforcement, and loads from text files
- Imports section shape and reinforcement from DXF files
- Imports loads from ETABS models
- Exports section shape and reinforcement to DXF files
- Tools for creating and modifying irregular sections
- Tools for creating sections with multiple solids and multiple openings
- Tables module for viewing and exporting input and output data
- Reporter module for generating, viewing, exporting and printing results
- Exports graphical reports (screen printouts) to EMF files
- Exports P-M diagrams,  $M_x$ - $M_y$  diagrams, and 3D failure surface to TXT and CSV files
- GUI (Graphical User Interface) and batch mode (command prompt) runs
- Reports neutral axis location and maximum steel strain corresponding to section capacity
- Reports neutral axis location, net tensile steel strain, and strength reduction factors in text output

## 1.2. Program Capacity

---

- 10,000 reinforcing bars within a section.
- 10,000 exterior points that define the geometric outline of the cross section.
- 10,000 interior points that define an opening in the cross section.
- 10,000 factored load entries, each consisting of an axial load, a moment about the x-axis, and a moment about the y-axis.
- 50 service load entries, each consisting of dead, live, wind, earthquake, and snow axial loads, moments at column top about the x and y axes, and moments at column bottom about the x and y axes.
- 50 load combinations.

## 1.3. System Installation Requirements

---

Any computer running Microsoft Windows 10, or Windows 11 operating system with 32 or 64 bit processing is sufficient to run the spColumn program. For instructions on how to troubleshoot system specific installation and licensing issues, please refer to support pages on StructurePoint website at [www.StructurePoint.org](http://www.StructurePoint.org).

---

## 1.4. Terms & Conventions

---

The following terms are used throughout this manual. A brief explanation is given to help familiarize you with them.

<b>Windows</b>	refers to the Microsoft Windows environment as listed in System Requirements.
<b>[]</b>	indicates metric equivalent
<b>Click on</b>	means to position the cursor on top of a designated item or location and press and release the left-mouse button (unless instructed to use the right-mouse button).
<b>Double-click on</b>	means to position the cursor on top of a designated item or location and press and release the left-mouse button twice in quick succession.

To help you locate and interpret information easily, the spColumn manual adheres to the following text format.

<i>Italic</i>	indicates a glossary item, or emphasizes a given word or phrase.
<b>Bold</b>	indicates the name of a menu or a menu item command such as <b>File</b> or <b>Save</b> .
Mono-space	indicates something you should enter with the keyboard. For example “c:\*.txt”.
KEY + KEY	indicates a key combination. The plus sign indicates that you should press and hold the first key while pressing the second key, then release both keys. For example, “ALT + F” indicates that you should press the “ALT” key and hold it while you press the “F” key. then release both keys.
SMALL CAPS	Indicates the name of an object such as a dialog box or a dialog box component. For example, the OPEN dialog box or the CANCEL or MODIFY buttons.

CHAPTER

2

## SOLUTION METHODS

---

### 2.1. Introduction

---

spColumn is widely used for design and investigation of columns, shear walls, bridge piers as well as typical framing elements in buildings and structures including foundation piles and caissons. Equipped with the American (ACI 318) and Canadian (CSA A23.3) Concrete codes, spColumn is developed to design and investigate any reinforced concrete sections subject to combined axial and flexural loads. In sway and non-sway frames, spColumn can analyze second order (P-Delta) effects using the moment magnification method when slenderness considerations are required.

Formerly pcaColumn, PCACOL, and IrrCOL, spColumn investigates sections that are impossible to find on design charts or to do by hand. The section can be rectangular, round or irregular, with any reinforcement layout or pattern. The program offers investigation of irregularly shaped, reinforced concrete column sections that may contain one or more solids and openings. Top selling worldwide, spColumn provides a full featured 3D visualization of the nominal and factored failure surface. Import/export DXF files, nominal interaction diagrams, and display of capacities at your load point are just a few of the rich program features.

### 2.1.1. Column Systems

spColumn can be used to model, analyze, and design column systems based on slenderness, loading, shape, reinforcement layout, confinement type, or application such as building columns, shear walls, bridges, piers / pilaster, sound walls, architectural columns and beams. Samples of such systems are illustrated below.

#### Building Columns

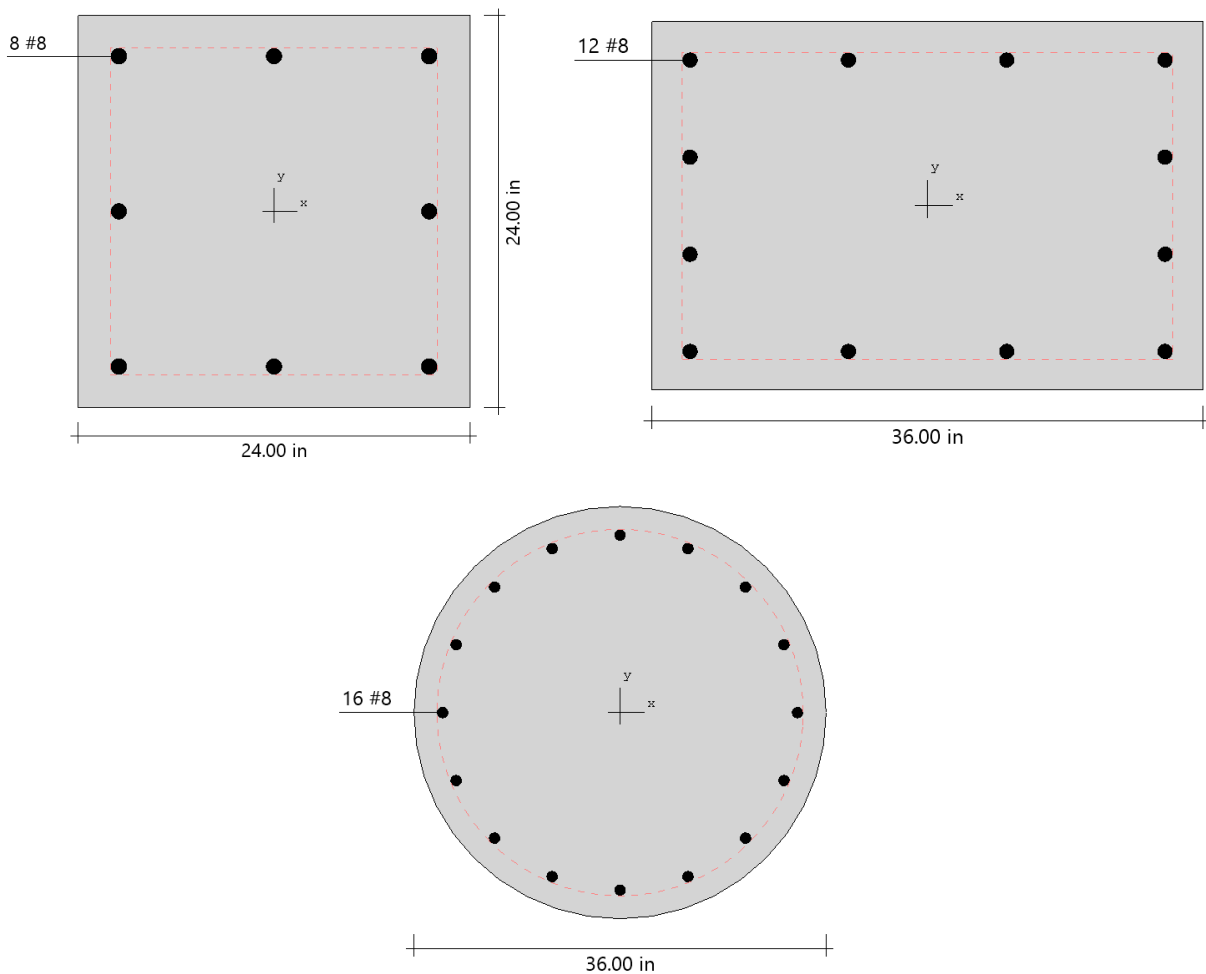

Shear Walls

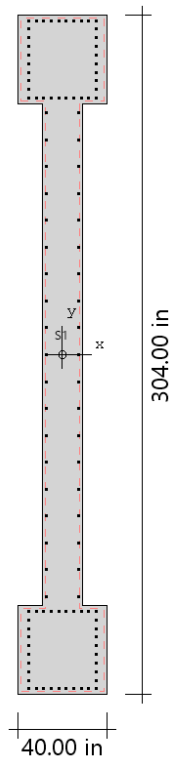
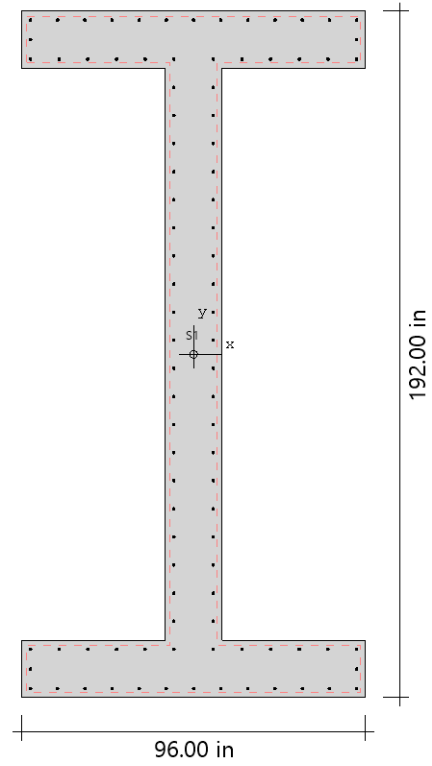
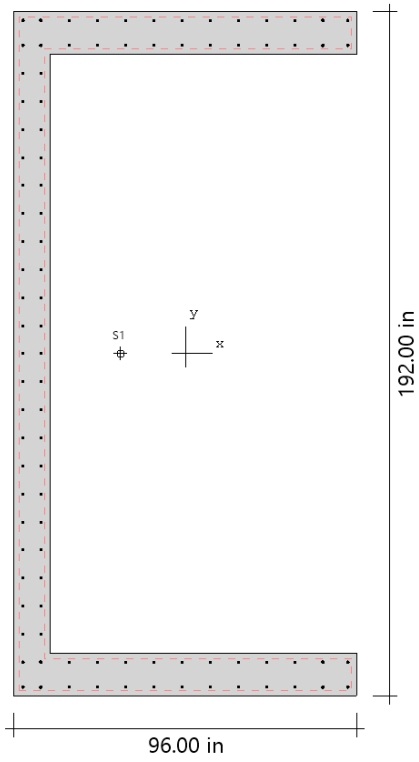

Bridges

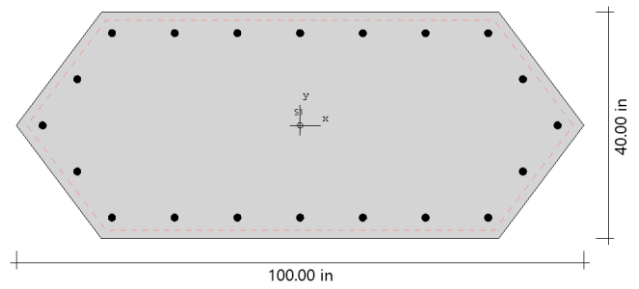
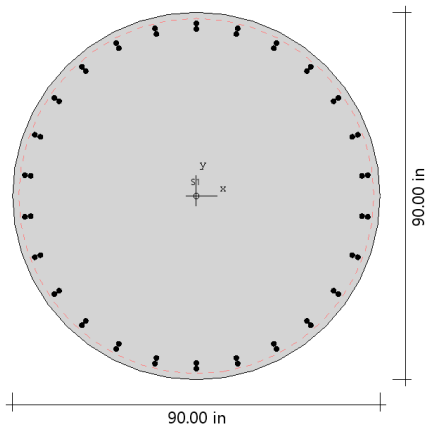
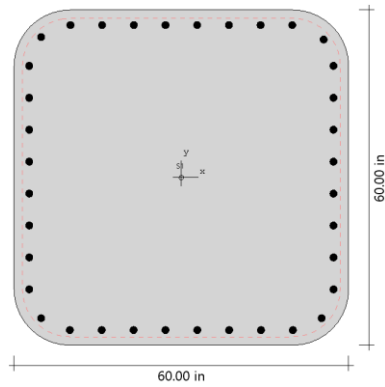
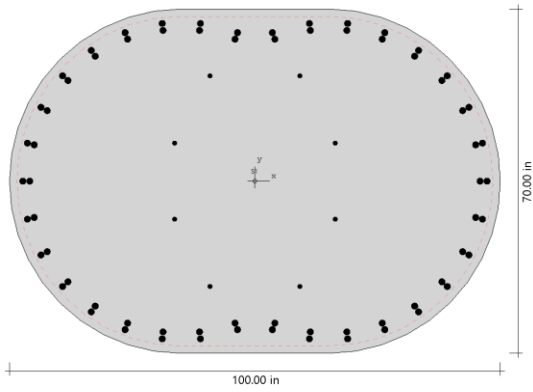

Piers/Pilasters

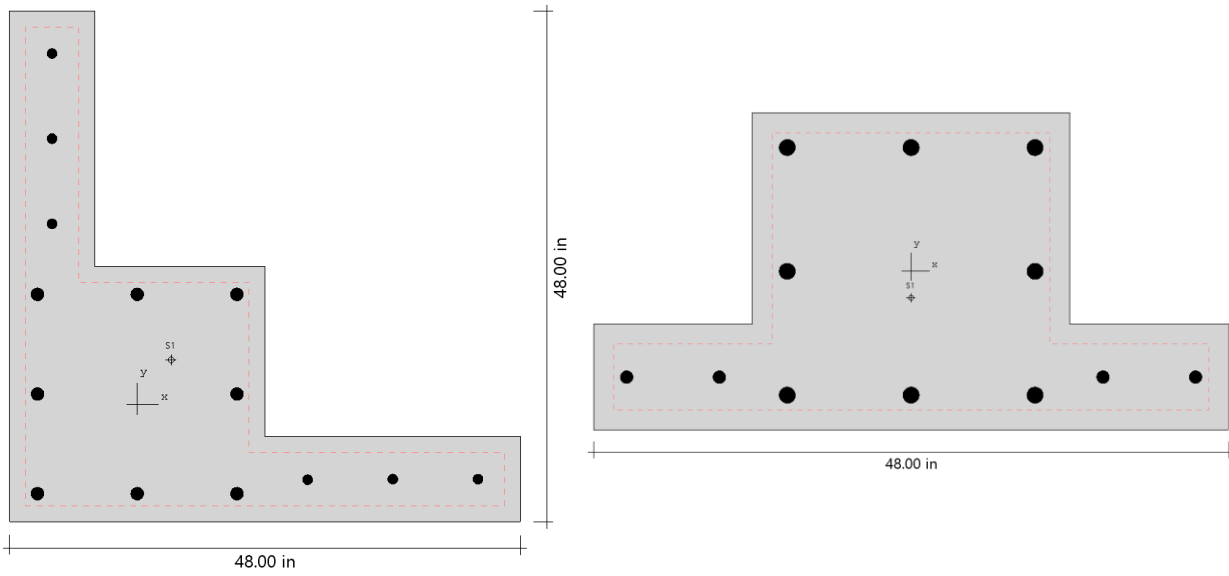

Sound Walls

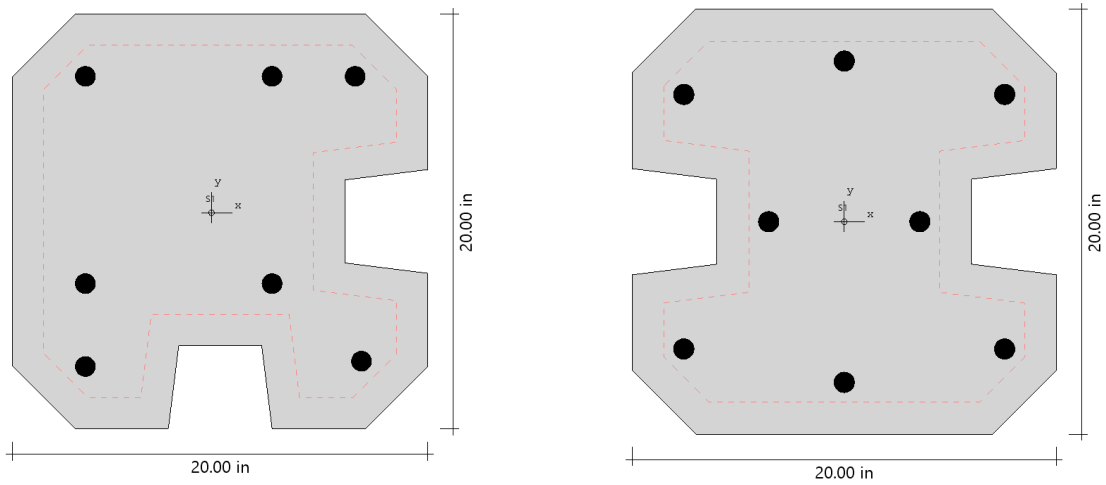

Architectural Columns

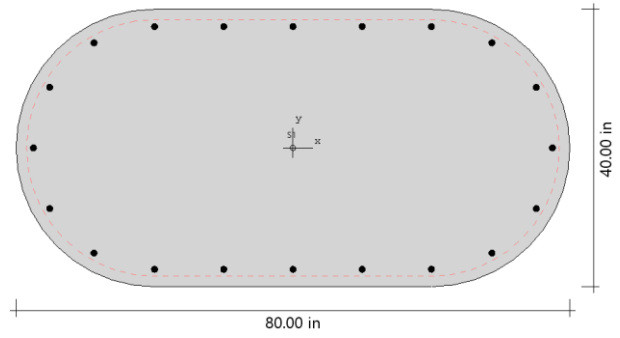
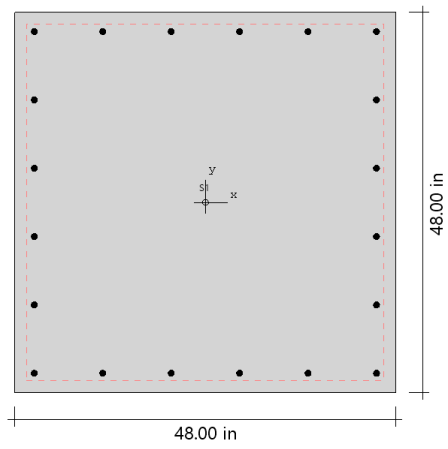

Beams

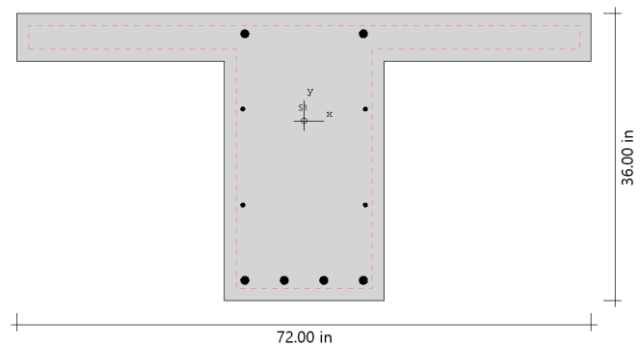
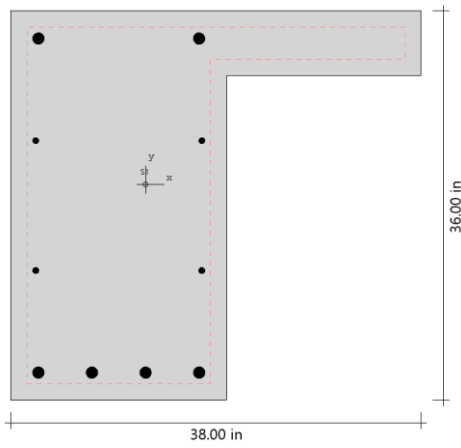

## 2.1.2. Coordinate Systems

### Global Coordinate System

1. Positive axial forces are compressive and negative axial forces are tensile.
2. Looking in plan at the section with z-axis pointing outwards, the positive x-axis points to the right and the positive y-axis points up. For this section, vectors of positive bending moments have the same orientation as their corresponding axes x and y. Thus, a positive bending moment about the x-axis,  $M_x$ , produces tension at the top face of the section and compression at the bottom face. A positive bending moment about the y-axis,  $M_y$ , produces tension at the left face of the section and compression at the right face.

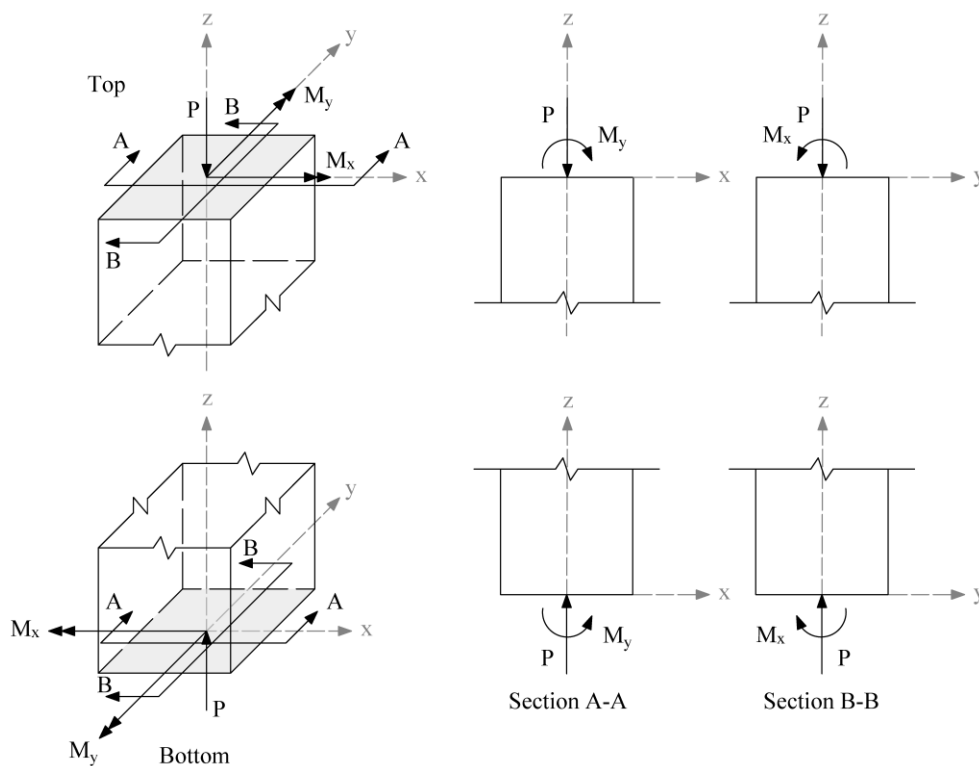

Figure 2.1 – Positive axial force and bending moments (internal forces)

3. If service loads are input, moment loads at the upper (top) and lower (bottom) ends of the column are needed. Top and bottom moment loads of opposite signs produce single curvature bending. Top and bottom moment loads of the same sign produce double curvature bending.

Positive moment loads at the upper end of the column coincide with positive bending moments. However, at the lower end, positive moment loads produce effects opposite to positive bending moments. Therefore, spColumn changes the sign of the service moment at the lower end to convert it from a moment load to a bending moment.

Axial load is assumed to be constant so it is input only as for the upper end where positive axial load coincides with positive axial force.

4. If factored loads are input, they are considered to be applied at a section pointing upwards so that they have the same orientations as positive axial force and positive bending moments.

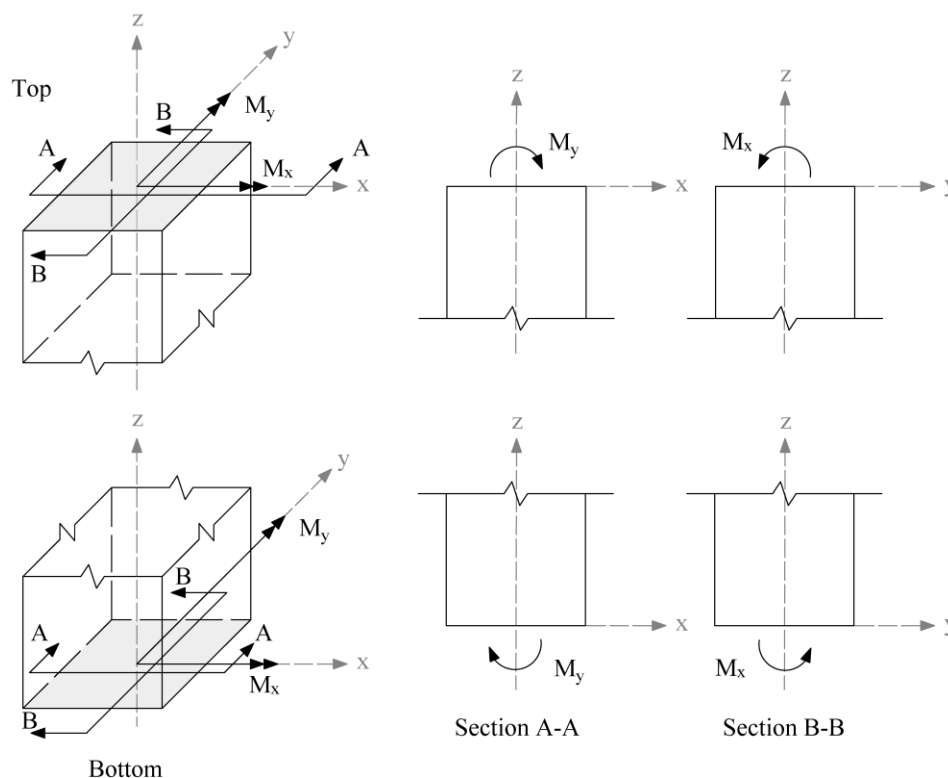

Figure 2.2 – Positive moments loads (external forces)

5. The convention for the slenderness input of beam and column dimensions and their orientation is presented in [Figure 2.3](#). Beams above the columns are shown. Same convention applies to beam below the column.

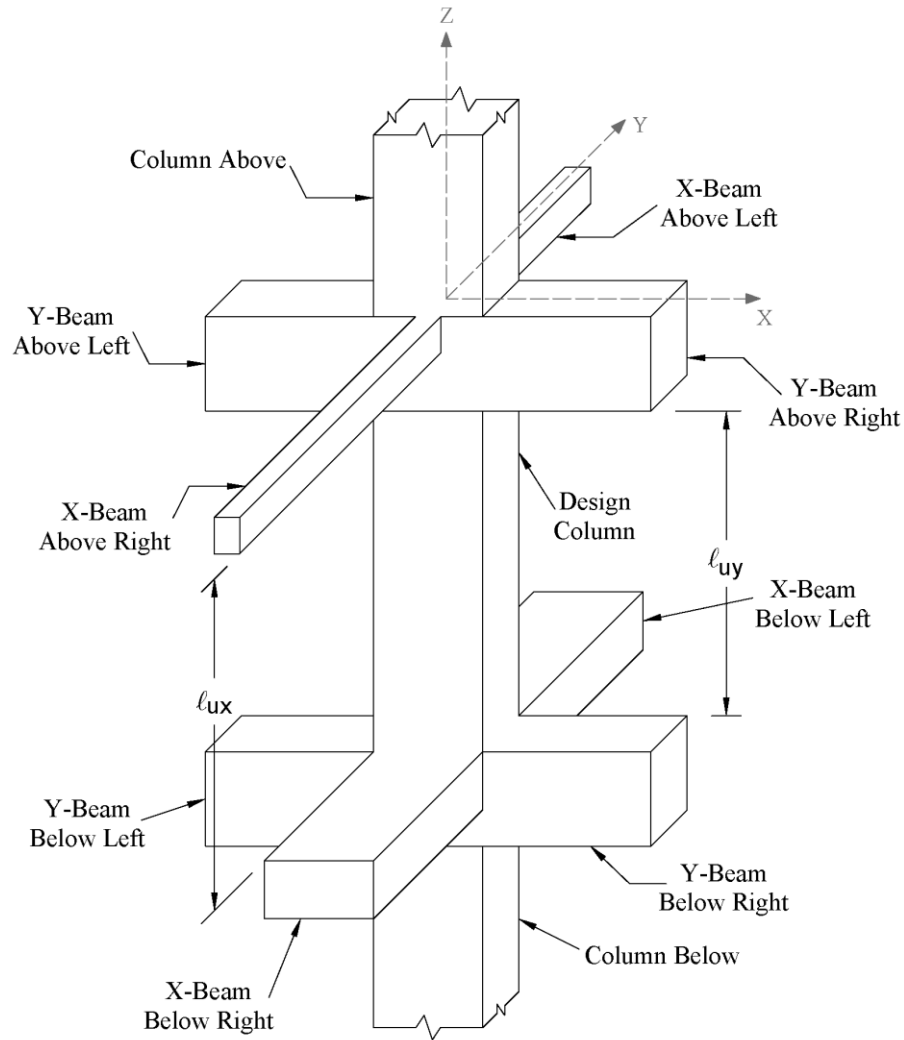

Figure 2.3 – Slenderness Input Convention

Local Coordinate System

There is no local coordinate system requirement in spColumn.

## 2.2. Codes and Standards Provisions

---

### 2.2.1. Code Checks

#### Geometry Considerations

The program does not perform any code checks regarding geometry considerations of the shapes in the model. End user must ensure the definitions and assumptions detailed in this chapter and in the applicable codes are in agreement with the intended final modeled section.

#### Material Considerations

The program does not perform any code checks regarding material considerations. The minimum and maximum values for material strengths input by the user and corresponding material properties calculated by the program for standard materials are listed in appendix of this manual.

#### Loading Considerations

External loads are applied according to the sign convention shown in [Figure 2.2](#). When slenderness is considered the sign convention of input service loads is critical to the correct calculation of the magnified moments resulting from second order effects.

### 2.2.2. Geometry Checks

#### Input Phase

The program is designed to receive user input consistent with conditions customary to standard detailing norms for conventional reinforced concrete members. Arrangements with very large sections, unusual layout of reinforcing bars, or academic and research conditions may receive a warning and request the user's attention before continuing to complete a section or solve a mode.

## Output Phase

The program does not perform any geometric checks during output phase. However, any warning pertaining to model adequacy, stability, or exceedance of limits is reported.

### 2.2.3. Definitions and Assumptions

1. The analysis of the reinforced concrete section performed by spColumn conforms to the provisions of the Strength Design Method<sup>1</sup> and Unified Design Provisions<sup>2</sup> and is based on the following assumptions.
  - a) All conditions of strength satisfy the applicable conditions of equilibrium and strain compatibility<sup>3</sup>
  - b) Strain in the concrete and in the reinforcement is directly proportional to the distance from the neutral axis<sup>4</sup>. In other words, plane sections normal to the axis of bending are assumed to remain plane after bending.
  - c) The maximum usable (ultimate) strain at the extreme concrete compression fiber is assumed equal to 0.003 for ACI codes<sup>5</sup> and 0.0035 for CSA codes<sup>6</sup> unless otherwise specified by the user.

<sup>1</sup> For CSA A23.3-19 (Ref. [18]) CSA A23.3-14 (Ref. [16]) CSA A23.3-04 (Ref. [8]) and CSA A23.3-94 (Ref.[9])

<sup>2</sup> For ACI 318-19 (Ref. [1]), ACI 318-14 (Ref. [2]), ACI 318-11 (Ref. [3]), ACI 318-08 (Ref. [4]), ACI 318-05 (Ref. [5]) and ACI 318-02 (Ref. [6]); also see notes on ACI 318-08, 8.1.2 in Ref. [11] and notes on ACI 318-11, 8.1.2 in Ref. [15]

<sup>3</sup> ACI 318-19, 4.5.1, 22.2.1.1, 13.2.6.4; ACI 318-14, 4.5.1, 22.2.1.1, 13.2.6.2; ACI 318-11, 10.2.1; ACI 318-08, 10.2.1; ACI 318-05, 10.2.1; ACI 318-02, 10.2.1; CSA A23.3-19, 10.1.1; CSA A23.3-14, 10.1.1; CSA A23.3-04, 10.1.1; CSA A23.3-94, 10.1.1

<sup>4</sup> ACI 318-19, 22.1.2, 22.2.1.2; ACI 318-14, 22.1.2, 22.2.1.2; ACI 318-11, 10.2.2; ACI 318-08, 10.2.2; ACI 318-05, 10.2.2; ACI 318-02, 10.2.2; CSA A23.3-19, 10.1.2; CSA A23.3-14, 10.1.2; CSA A23.3-04, 10.1.2; CSA A23.3-94, 10.1.2

<sup>5</sup> ACI 318-19, 22.2.2.1; ACI 318-14, 22.2.2.1; ACI 318-11, 10.2.3; ACI 318-08, 10.2.3; ACI 318-05, 10.2.3; ACI 318-02, 10.2.3

<sup>6</sup> CSA A23.3-19, 10.1.3; CSA A23.3-14, 10.1.3; CSA A23.3-04, 10.1.3; CSA A23.3-94, 10.1.3

- d) A uniform rectangular concrete stress block is used. For ACI code<sup>7</sup>, the maximum uniform concrete compressive stress,  $f_c$ , is  $0.85 f_c'$  by default and the block depth is  $\beta_1 c$ , where  $c$  is the distance from the extreme compression fiber to the neutral axis and  $\beta_1$  is described in item 4 below. For CSA<sup>8</sup>,  $f_c$  is taken as:

$$f_c = (0.85 - 0.0015 f_c') f_c' \geq 0.68 f_c', \text{ where } f_c' \text{ is in MPa}$$

Both  $f_c$  and  $\beta_1$  can be modified by the user.

- e) Concrete displaced by the reinforcement in compression is deducted from the compression block<sup>9</sup>
- f) For the reinforcing steel, the elastic-plastic stress-strain distribution is used<sup>10</sup>. Stress in the reinforcing steel below the yield strength,  $f_y$ , is directly proportional to the strain. For strains greater than that corresponding to the yield strength, the reinforcement stress remains constant and equal to  $f_y$ . Reinforcing steel yield strength must be within customary ranges.
- g) Tensile strength of concrete in axial and flexural calculations is neglected<sup>11</sup>.
- h) Reinforcement bars are located within section outline.
- i) Irregular sections must be composed of a closed polygon without any intersecting sides.

<sup>7</sup> ACI 318-19, 22.2.2.3; ACI 318-14, 22.2.2.3; ACI 318-11, 10.2.6; ACI 318-08, 10.2.6, 10.2.7; ACI 318-05, 10.2.6, 10.2.7; ACI 318-02, 10.2.6, 10.2.6

<sup>8</sup> CSA A23.3-19, 10.1.1; CSA A23.3-14, 10.1.1; CSA A23.3-04, 10.1.1; CSA A23.3-94, 10.1.1

<sup>9</sup> For consistency with Eq. 22.4.2.4 in ACI codes (Refs. [1], [2]) and for consistency with Eq. 10-1 and 10-2 in ACI codes (Refs. [3], [4], [5], [6]) and with Eq. 10-10 in CSA codes (Refs. [8], [9])

<sup>10</sup> ACI 318-19, 20.2.2.1; ACI 318-14, 20.2.2.1; ACI 318-11, 10.2.4; ACI 318-08, 10.2.4; ACI 318-05, 10.2.4; ACI 318-02, 10.2.4; CSA A23.3-19, 8.5.3.2; CSA A23.3-14, 8.5.3.2; CSA A23.3-04, 8.5.3.2; CSA A23.3-94, 8.5.3.2

<sup>11</sup> ACI 318-19, 22.2.2.2; ACI 318-14, 22.2.2.2; ACI 318-11, 10.2.5; ACI 318-08, 10.2.5; ACI 318-05, 10.2.5; ACI 318-02, 10.2.5; CSA A23.3-19, 10.1.5; CSA A23.3-14, 10.1.5; CSA A23.3-04, 10.1.5; CSA A23.3-94, 10.1.5

j) Members with very large cross sectional area, multiple solids, multiple openings, and unusual geometry must be carefully evaluated in light of above assumption for solution stability and reliability of results.

2. The modulus of elasticity of concrete,  $E_c$  is computed as follows (unless otherwise specified by the user):

$$E_c = 57,000\sqrt{f'_c} \text{ for the ACI code}^{12} \text{ where } f'_c \text{ and } E_c \text{ are in psi,}$$

$$E_c = 4,700\sqrt{f'_c}, \text{ for the ACI code}^{13} \text{ where } f'_c \text{ and } E_c \text{ are in MPa.}$$

For the CSA standard<sup>14</sup>,  $E_c = 3,518\sqrt{f'_c} + 7,355$ , where  $f'_c$  and  $E_c$  are in MPa.

3. The modulus of elasticity of reinforcing steel<sup>15</sup>,  $E_s$ , is taken as 29,000 ksi (200,000 MPa) unless otherwise specified by the user. For non-standard materials, the compression-controlled strain limit input by the user cannot exceed 0.005 for ACI 318-14 and prior, or 0.01 for ACI 318-19.

<sup>12</sup> ACI 318-19, 19.2.2.1; ACI 318-14, 19.2.2.1; ACI 318-11, 8.5.1; ACI 318-08, 8.5.1; ACI 318-05, 8.5.1; ACI 318-02, 8.5.1

<sup>13</sup> ACI 318M-19, 19.2.2.1; ACI 318M-14, 19.2.2.1; ACI 318M-11, 8.5.1; ACI 318M-08, 8.5.1; ACI 318M-05, 8.5.1; ACI 318M-02, 8.5.1

<sup>14</sup> CSA A23.3-19, 8.6.2.2, Eq. 8.1, CSA A23.3-14, 8.6.2.2, Eq. 8.1, CSA A23.3-04, 8.6.2.2, Eq. 8.1 and CSA A23.3-94, 8.6.2.3, Eq. 8-6 (with  $\gamma_c = 2400 \text{ kg/m}^3$ )

<sup>15</sup> ACI 318-19, 20.2.2.2; ACI 318-14, 20.2.2.2; ACI 318-11, 8.5.2; ACI 318-08, 8.5.2; ACI 318-05, 8.5.2; ACI 318-02, 8.5.2; ACI 318M-05, 8.5.2; ACI 318M-02, 8.5.2; CSA A23.3-19, 8.5.4.1; CSA A23.3-14, 8.5.4.1; CSA A23.3-04, 8.5.4.1; CSA A23.3-94, 8.5.4.1

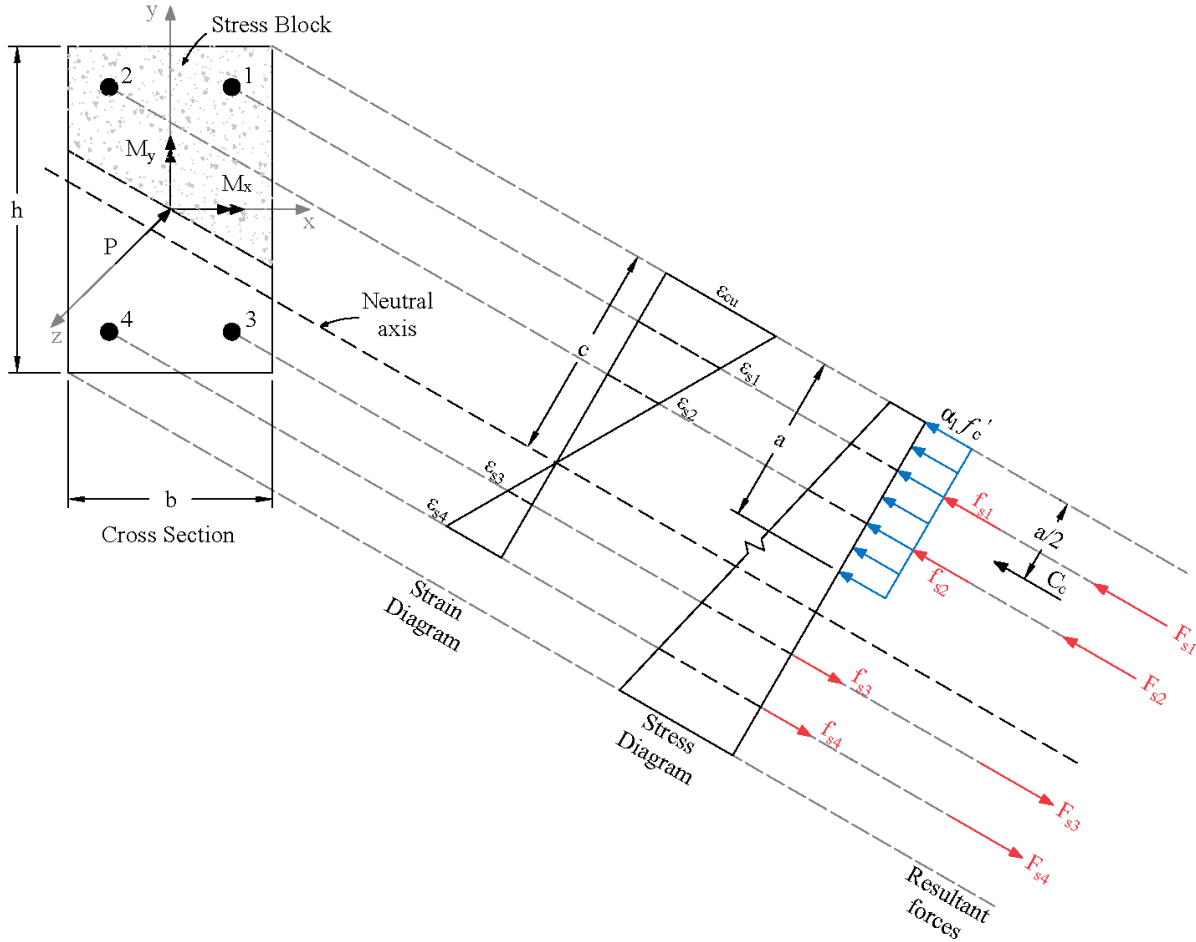

Figure 2.4 – Analysis of Reinforced Section

4. The ratio of the concrete compression block depth to the distance between the extreme compression fiber and the neutral axis,  $\beta_1$ , is computed as follows (unless otherwise specified by the user):

$$0.65 \leq \beta_1 = 1.05 - 0.05 f'_c \leq 0.85, \text{ for the ACI code}^{16} \text{ where } f'_c \text{ is in ksi,}$$

$$0.65 \leq \beta_1 = (149 - f'_c) / 140 \leq 0.85, \text{ for the ACI code}^{17} \text{ where } f'_c \text{ is in MPa.}$$

<sup>16</sup> ACI 318-19, 22.2.2.4.3; ACI 318-14, 22.2.2.4.3; ACI 318-11, 10.2.7.3; ACI 318-08, 10.2.7.3; ACI 318-05, 10.2.7.3; ACI 318-02, 10.2.7.3

<sup>17</sup> ACI 318M-19, 22.2.2.4.3; ACI 318M-14, 22.2.2.4.3; ACI 318M-11, 10.2.7.3; ACI 318M-08, 10.2.7.3; ACI 318M-05, 10.2.7.3; ACI 318M-02, 10.2.7.3

For the CSA standard<sup>18</sup>,  $\beta_1 = 0.97 - 0.0025 f'_c \geq 0.67$ , where  $f'_c$  is in MPa.

5. Stress in the reinforcement is computed based on the strain at the centroid of each reinforcing bar.
6. All moments are referenced to the geometric centroid of the gross concrete section (neglecting the reinforcement).
7. For the ACI codes, the nominal (unreduced) capacity of the section is first computed. Then, the nominal capacity is reduced to the design capacity using the strength reduction factor,  $\phi$ , the value of which is calculated based on the net tensile steel strain,  $\varepsilon_t$ , in the following way<sup>19</sup>.

- For columns with spiral reinforcement per ACI 318-19

$$\phi = \begin{cases} 0.90 & \text{if } \varepsilon_t \geq \varepsilon_{ty} + 0.003 \text{ (tension controlled section)} \\ 0.75 + \frac{0.15(\varepsilon_t - \varepsilon_{ty})}{0.003} & \text{if } \varepsilon_{ty} < \varepsilon_t < \varepsilon_t + 0.003 \text{ (transition section)} \\ 0.75 & \text{if } \varepsilon_t \leq \varepsilon_{ty} \text{ (compression controlled section)} \end{cases}$$

Where  $\varepsilon_{ty} = f_y / E_s$

- For columns with spiral reinforcement per ACI 318-14, ACI 318-11, and ACI 318-08

$$\phi = \begin{cases} 0.90 & \text{if } \varepsilon_t \geq 0.005 \text{ (tension controlled section)} \\ 0.75 + \frac{0.15(\varepsilon_t - f_y / E_s)}{0.005 - f_y / E_s} & \text{if } f_y / E_s < \varepsilon_t < 0.005 \text{ (transition section)} \\ 0.75 & \text{if } \varepsilon_t \leq f_y / E_s \text{ (compression controlled section)} \end{cases}$$

<sup>18</sup> CSA A23.3-19, 10.1.7(c); CSA A23.3-14, 10.1.7(c); CSA A23.3-04, 10.1.7(c); CSA A23.3-94, 10.1.7(c)

<sup>19</sup> ACI 318-19, 21.2; ACI 318-14, 21.2; ACI 318-11, 9.3.2, 10.3.3, 10.3.4; ACI 318-08, 9.3.2, 10.3.3, 10.3.4; ACI 318-05, 9.3.2, 10.3.3, 10.3.4; ACI 318-02, 9.3.2, 10.3.3, 10.3.4

- For columns with spiral reinforcement per ACI 318-05 and ACI 318-02

$$\phi = \begin{cases} 0.90 & \text{if } \varepsilon_t \geq 0.005 \text{ (tension controlled section)} \\ 0.70 + \frac{0.20(\varepsilon_t - f_y / E_s)}{0.005 - f_y / E_s} & \text{if } f_y / E_s < \varepsilon_t < 0.005 \text{ (transition section)} \\ 0.70 & \text{if } \varepsilon_t \leq f_y / E_s \text{ (compression controlled section)} \end{cases}$$

- For other columns per ACI 318-19

$$\phi = \begin{cases} 0.90 & \text{if } \varepsilon_t \geq \varepsilon_{ty} + 0.003 \text{ (tension controlled section)} \\ 0.65 + \frac{0.25(\varepsilon_t - \varepsilon_{ty})}{0.003} & \text{if } \varepsilon_{ty} < \varepsilon_t < \varepsilon_t + 0.003 \text{ (transition section)} \\ 0.65 & \text{if } \varepsilon_t \leq \varepsilon_{ty} \text{ (compression controlled section)} \end{cases}$$

Where  $\varepsilon_{ty} = f_y / E_s$

- For other columns per ACI 318-14, ACI 318-11, ACI 318-08, ACI 318-05, and ACI 318-02

$$\phi = \begin{cases} 0.90 & \text{if } \varepsilon_t \geq 0.005 \text{ (tension controlled section)} \\ 0.65 + \frac{0.25(\varepsilon_t - f_y / E_s)}{0.005 - f_y / E_s} & \text{if } f_y / E_s < \varepsilon_t < 0.005 \text{ (transition section)} \\ 0.65 & \text{if } \varepsilon_t \leq f_y / E_s \text{ (compression controlled section)} \end{cases}$$

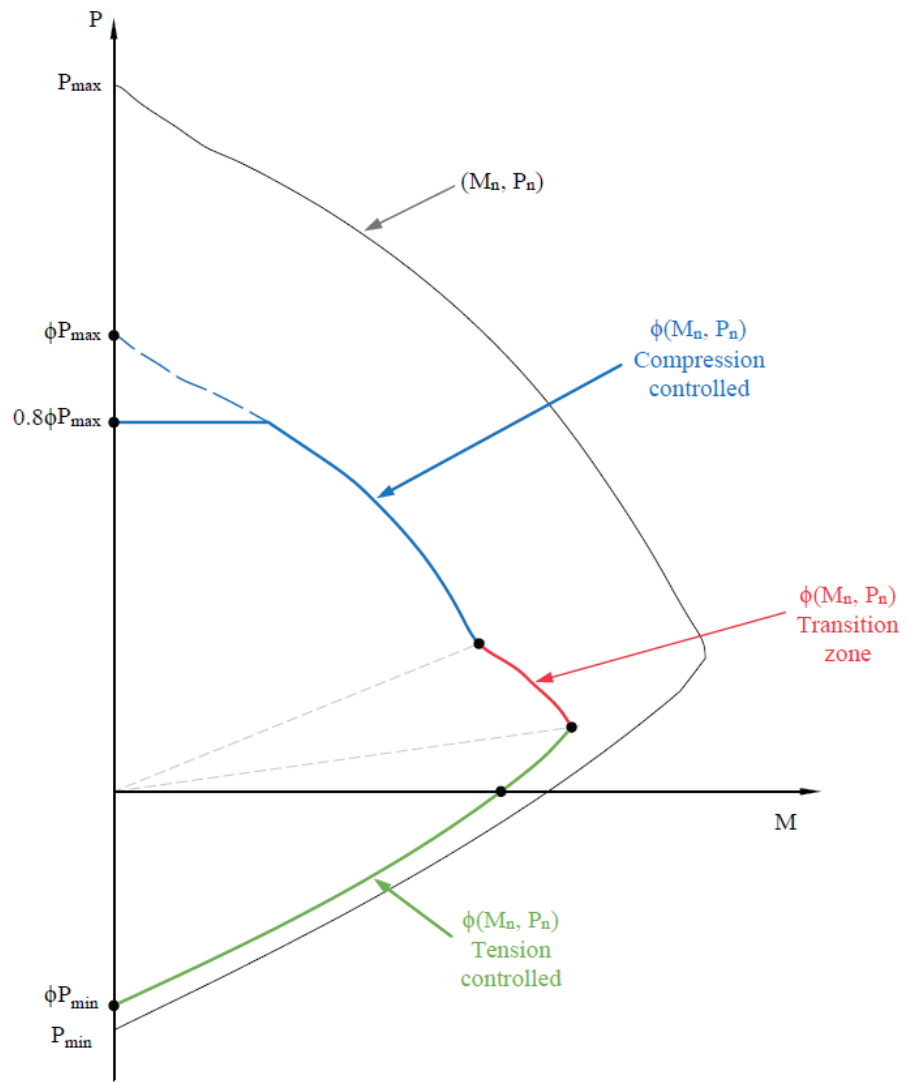
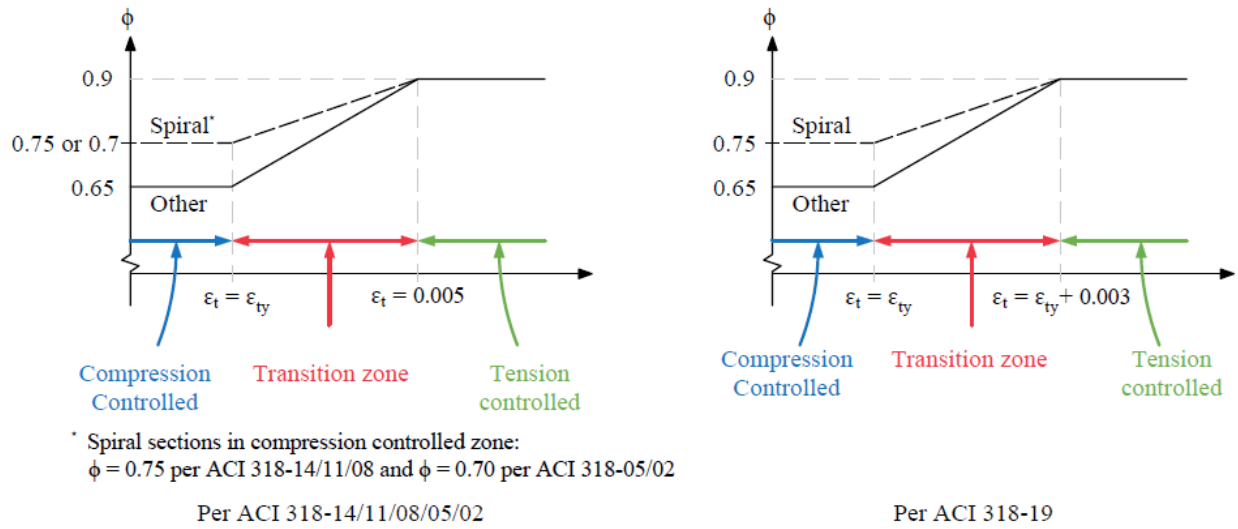

Figure 2.5 – Reduction factors for Flexural and Axial Capacity per ACI Code

Figure 2.5 illustrates variation of the strength reduction factor with net tensile strain in extreme tension steel and the impact of the strength reduction factor on the axial and flexural capacity interaction diagram. It is worth noting that in the transition between compression controlled and tension controlled zones, the nominal axial capacity,  $P_n$ , decreases whereas the value of net tensile strain increases and so does the strength reduction factor,  $\phi$ . Consequently, the resulting factored axial capacity (i.e. the product of nominal axial capacity and the strength reduction factor),  $\phi P_n$ , may either increase or decrease in the transition zone depending on the rates of axial force decrease and strength reduction increase for the section under consideration. Typically, the rate of axial capacity decrease dominates over the rate of strength reduction increase and thus the factored axial load capacity decreases as well.

For certain classes of sections (e.g. sections having a narrowing in the middle such as hollow core section, T-shaped, L-shaped, and I-shaped sections), however, the reverse may be true resulting in the factored axial load capacity increase in the transition zone between compression controlled and tension controlled zones. This unusual increase in axial load capacity is not illustrated by interaction diagrams produced by the program and is not considered for design and investigation of cross-sections. It will be flagged to inform the user, however, when the program is run using Control Points as the load type.

Where unsymmetrical members (e.g. C-shaped or U-shaped sections) are investigated under biaxial bending, the  $M_x$ - $M_y$  contour diagram occasionally crosses the X or Y axes more than once. This presents an unusual situation where a load point may exist outside of the  $M_x$ - $M_y$  contour while appearing within the P- $M_x$  or P- $M_y$  contour views. It is suggested the  $M_x$ - $M_y$  contours be investigated carefully for each factored axial load level.

For the CSA standards, the program calculates the factored resistance directly using the factored compressive concrete strength<sup>20</sup>,  $\phi_c f_c'$ , and the factored forces in reinforcement bars<sup>21</sup>,  $\phi_s S_i$ . The material resistance factors are:

---

<sup>20</sup> CSA A23.3-19, 8.4.2, CSA A23.3-14, 8.4.2, 16.1.3; CSA A23.3-04, 8.4.2, 16.1.3; CSA A23.3-94, 8.4.2

<sup>21</sup> CSA A23.3-19, 8.4.3; CSA A23.3-14, 8.4.3; CSA A23.3-04, 8.4.3; CSA A23.3-94, 8.4.3

$\phi_c = 0.60$  for CSA A23.3-94

= 0.65 for CSA A23.3-04/14/19 (cast-in-place)

= 0.70 for CSA A23.3-04/14/19 (precast)

$\phi_s = 0.85$  for CSA A23.3-94/04/14/19

For all ACI and CSA A23.3-94/04 standards, the design axial capacity is capped<sup>22</sup> at 0.85 of the maximum axial capacity for sections with spiral reinforcement or at 0.80 for sections with tie reinforcement.

Additionally, for CSA A23.3-14 and CSA A23.3-19 the design axial capacity is capped<sup>23</sup> at 0.90 of the maximum axial capacity for sections with spiral reinforcement or at  $(0.2+0.002h) \leq 0.80$  for sections with tie reinforcement where h is the wall thickness or the minimum column dimension.

---

<sup>22</sup> ACI 318-19, 22.4.2.1; ACI 318-14, 22.4.2.1; ACI 318-11, 10.3.6; ACI 318-08, 10.3.6; ACI 318-05, 10.3.6; ACI 318-02, 10.3.6; CSA A23.3-14, 10.10.4; CSA A23.3-04, 10.10.4; CSA A23.3-94, 10.10.4

<sup>23</sup> CSA A23.3-19, 10.10.4; CSA A23.3-14, 10.10.4

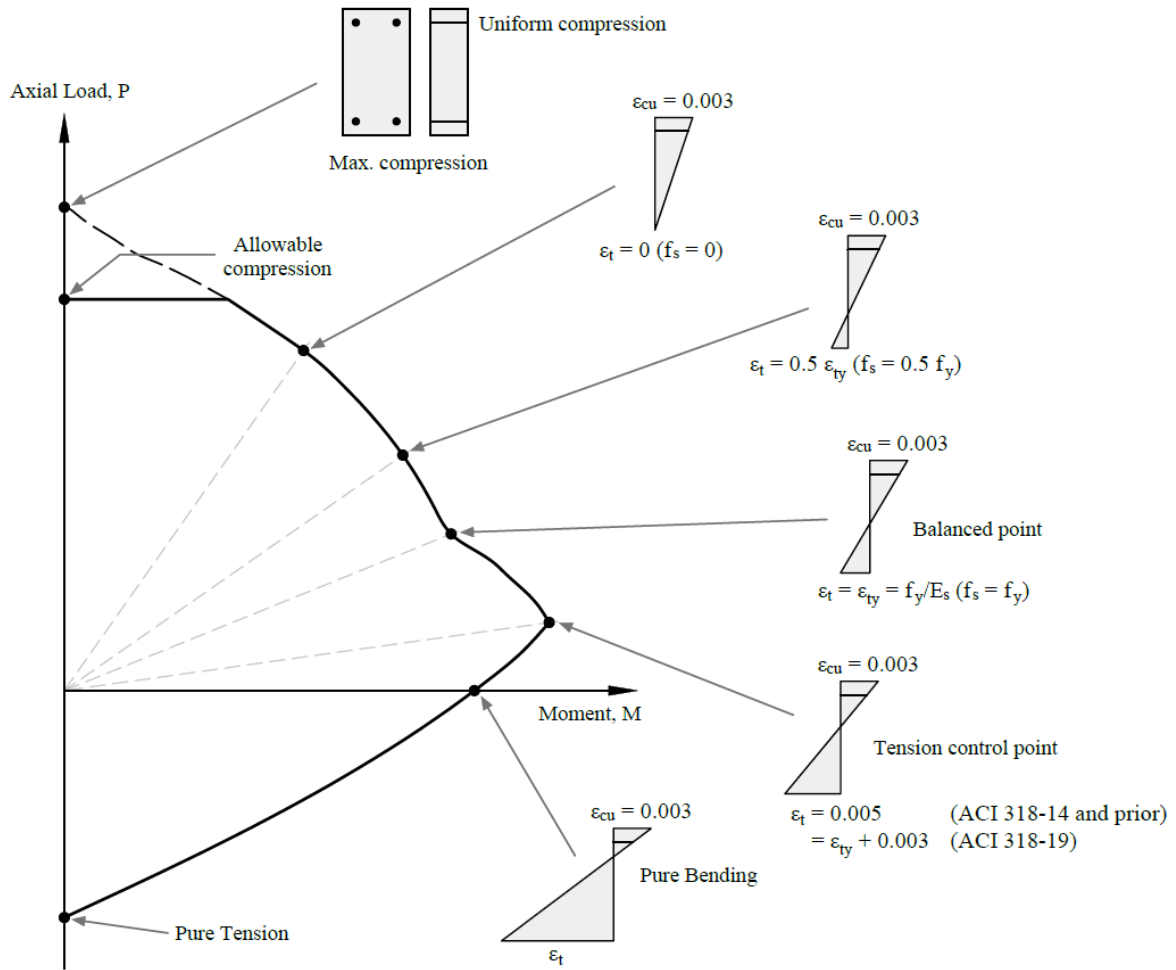

Figure 2.6 – Shapes of Factored (Design) P-M interaction diagram for ACI Code

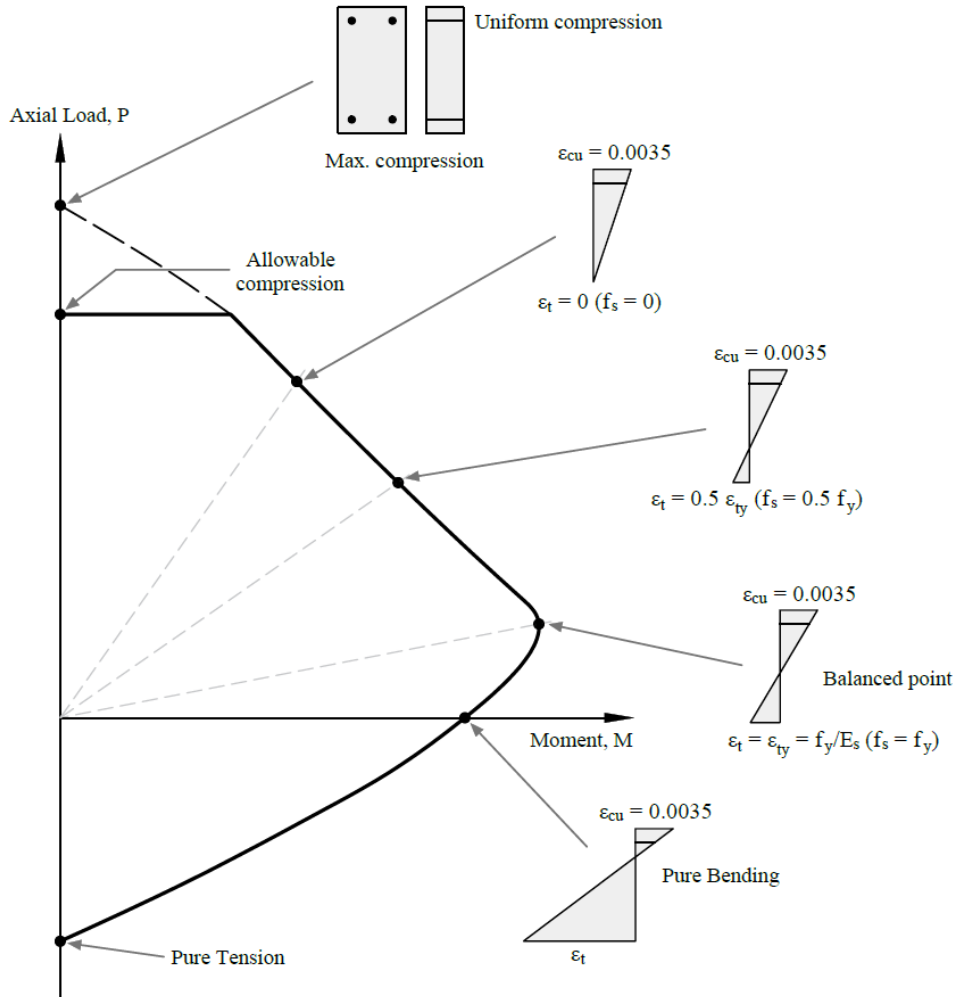

Figure 2.7 – Shapes of Factored (Design) P-M interaction diagram for CSA Standard

8. In the investigation mode the program will calculate capacity for any provided area of reinforcement. However, if the reinforcement area falls below the code-specified<sup>24</sup> minimum of 0.01 times the gross area,  $A_g$ , then two options, *Architectural* or *Structural*, are available.

By default, *Architectural* option is selected for which the capacity of the section is reduced. For the ACI codes, the reduction results from multiplying the maximum concrete stress,  $f_c'$ , by the ratio of reinforcement area to  $0.01A_g$ . This produces the same effect as reducing the effective concrete area<sup>25</sup> to achieve ratio of reinforcement area to gross concrete area equal to 0.01. For the CSA standards<sup>26</sup>, the factored axial and flexural resistances are multiplied by ratio  $0.5 (1 + \rho_t / 0.01)$  for the 04 edition and  $\rho_t / 0.01$  for the 94 edition.

For *Structural* option, the section is treated “as is” without any reductions in capacity. This option is provided for informational purposes only, since per all codes supported by spColumn, capacity of compression members with reinforcement area less than  $0.01A_g$  has to be reduced and areas below  $0.005A_g$  are not allowed.

9. Under the Design option, the reinforcement ratio cannot be less than 1.0% if *Structural* column type is selected in design criteria and 0.5% in case of *Architectural* column type. For *Architectural* type, the capacity of the designed column is reduced as described above. Additionally, *User Defined* type is provided in the design criteria, which allows designs with reinforcement ratios not less than 0.1%. No reduction in capacity is applied for User Defined column type.

---

<sup>24</sup> ACI 318-19, 10.6.1.1; ACI 318-14, 10.6.1.1; ACI 318-11, 10.9.1; ACI 318-08, 10.9.1; ACI 318-05, 10.9.1; ACI 318-02, 10.9.1; CSA A23.3-19, 10.9.1; CSA A23.3-14, 10.9.1; CSA A23.3-04, 10.9.1; CSA A23.3-94, 10.9.1

<sup>25</sup> ACI 318-19, 10.3.1.2; ACI 318-14, 10.3.1.2; ACI 318-11, 10.8.4; ACI 318-08, 10.8.4; ACI 318-05, 10.8.4; ACI 318-02, 10.8.4

<sup>26</sup> CSA A23.3-19, 10.10.5; CSA A23.3-14, 10.10.5; CSA A23.3-04, 10.10.5; CSA A23.3-94, 10.10.5

10. Maximum reinforcement ratio<sup>27</sup> for *Structural* and *Architectural* options in both Investigation and Design modes is 8%. For *User Defined* type in the Design mode the maximum reinforcement ratio is set to 20%.
  
11. Reinforcement design strength for standard materials is limited to the value permitted for design calculations<sup>28</sup> by ACI to 80 ksi and CSA to 500 MPa.

---

<sup>27</sup> ACI 318-19, 10.6.1.1; ACI 318-14, 10.6.1.1; ACI 318-11, 10.9.1; ACI 318-08, 10.9.1; ACI 318-05, 10.9.1; ACI 318-02, 10.9.1; CSA A23.3-19, 10.9.2; CSA A23.3-14, 10.9.2; CSA A23.3-04, 10.9.2; CSA A23.3-94, 10.9.2

<sup>28</sup> ACI 318-19, Table 20.2.2.4a; ACI 318-14, Table 20.2.2.4a; CSA A23.3-19, 8.5.1; CSA A23.3-14, 8.5.1

---

## 2.3. Analysis Methods

---

### 2.3.1. Section Investigation Mode

Investigation mode is used when the section shape and reinforcement is known or predetermined by the user. User can evaluate different modifications to the shape and its geometry and separately or simultaneously make changes to the reinforcing arrangement. The section strength can be investigated for as many iterations as required by the user to meet the demand for applied service or factored loads. Alternatively, investigation can be conducted without loads to evaluate section strength at various axial load levels or at critical control point on the interaction diagram.

In other words, the investigation mode allows the evaluation of the strength (interaction diagrams and 3D failure surfaces) and the adequacy of specific section shape and reinforcement. The adequacy of a section can be checked against factored loads which can be entered directly, or calculated internally if service loads are defined. The section interaction diagrams and 3D failure surfaces can be evaluated at specific axial load level, or at specific control point levels.

#### 2.3.1.1. Loading Options

The computations performed when investigating a section depend on the selected load or mode:

- a) **Factored loads** – for each load point, the capacity ratio is computed. For a biaxial run, the computed  $M_x$  and  $M_y$  moment capacities are at the same angle as that produced by the applied  $M_x$  and  $M_y$  moments. The program also reports the depth of neutral axis and maximum steel strain corresponding to the calculated capacity points. For the ACI code, the value of strength reduction factor is also reported.
- b) **Service loads** – the program calculates the factored loads using the input load combinations. If slenderness effects are to be checked and the column is found to be slender, the applied moments are magnified according to the moment magnification procedures described in this manual. For each calculated factored load, the same computations described for factored loads above are performed.

- c) **Axial load points** – this mode does not require load information. The user can provide a range of axial loads, for which the program calculates the positive and negative moment capacities together with the corresponding neutral axis depths and maximum steel strains. For ACI code, strength reduction factors are also reported.
- d) **Control points** – this mode does not require load information. For several key points on the interaction diagram, the program calculates axial load and moment capacity together with the neutral axis depth and maximum steel strain corresponding to the respective moment capacity. For ACI code, strength reduction factor is also reported. The following key points are used by the program: maximum compression, allowable compression, point where steel stress is zero, point where steel stress is  $0.5f_y$ , balanced point, pure bending and maximum tension. For ACI code, an additional control point is introduced where maximum steel strain is equal to tension control limit.

### 2.3.1.2. Interaction Diagram Options

The program also computes the interaction diagram (uniaxial runs) or the three-dimensional failure surface (biaxial runs) of the input section. The values of maximum compressive axial load capacity and maximum tensile load capacity are computed. These two values set the range within which the moment capacities are computed for a predetermined number of axial load values.

- a) For uniaxial runs, positive and negative moment capacities about only the selected axis (X-Axis or Y-Axis) are computed. Moment capacities about the orthogonal axis are ignored. To compute the moment capacity at a certain level of axial load, the neutral axis angle is held constant, parallel to the selected axis. The neutral axis depth is adjusted to arrive at the desired axial load capacity. This is done for all the predetermined values of axial load.
- b) For biaxial runs, the same predetermined values of axial load are utilized. For each level of axial load, the section is rotated in 10-degree increments from 0 degrees to 360 degrees and the  $M_x$  and  $M_y$  moment capacities are computed. Thus, for each level of axial load, an  $M_x$ - $M_y$  contour is developed. Repeating this for the entire range of axial loads, the three-dimensional failure surface is computed. A three-dimensional visualization of the resulting entire nominal and factored failure surface is provided to support enhanced understanding of the section capacity.

Also, for each point on the interaction diagram or on the three-dimensional failure surface, the program calculates the location of the neutral axis (expressed in terms of depth and angle of the neutral axis), maximum steel strain, and (for ACI codes only) the strength reduction factor. These results are reported for the maximum capacity of the section based on the ultimate limit states and not for the given loading input. The information can however be used to draw conclusions or make additional calculations for a given loading condition.

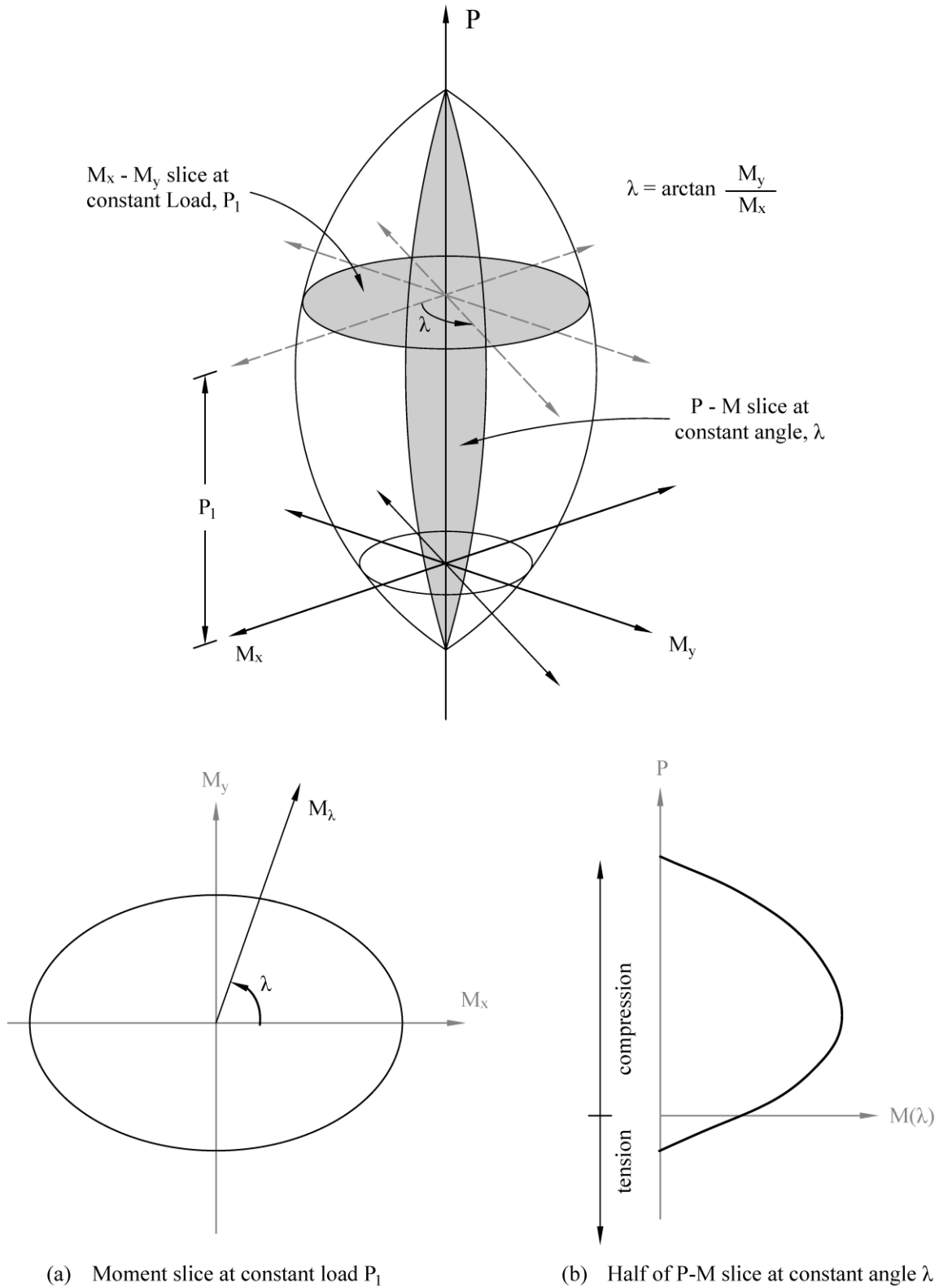

Figure 2.8 – Interaction Surface for Combined Axial Load and Biaxial Bending

### 2.3.2. Section Design Mode

Design mode is a very effective mode to determine the optimum section dimensions and reinforcement pattern for a set of user input applied loads. The program follows a sophisticated logic for iterative design cycles predicated on user provided criteria for the design. The design mode is applicable to regular rectangular and circular shapes with commonly encountered reinforcement arrangements. A trace of the design steps made by the program prior to arriving at the optimal final design section is made available to the user to review at the end of a run.

#### 2.3.2.1. Design Criteria

Design options available to control the design iterations are as follows:

1. **Column Type:** Selecting column type allows the modification of limiting minimum and maximum reinforcement ratios.
2. **Reinforcement Bars:** the user can control reinforcement bars layout based on minimum number of bars, or minimum area of steel. The user also has control over the minimum clear spacing between bars.
3. **Capacity Ratio:** the user can control the level of safety required in the design process using the allowable capacity ratio.

#### 2.3.2.2. Design Procedure

The program follows the steps below to conduct a design run for regular sections.

1. Based on the specified minimum, maximum and increment specified for the section and the reinforcing bars, the program selects the smallest section with the least amount of reinforcement for which the capacity exceeds the applied loads. If service loads are input, they are factored using the input load combinations. Depending on the design criteria the user selects, the program searches for the least amount of reinforcement based on either the smallest number of bars or the smallest steel area.

2. The program starts the design by trying the smallest section (minimum dimensions) and the least amount of reinforcing bars. The program verifies that the ratio of provided reinforcement is always within the specified minimum and maximum ratios. Furthermore, unless otherwise specified by the user<sup>29</sup>, the bar spacing is always kept greater than or equal to the larger of 1.5 times the bar diameter or 1.5 in. [40 mm] for ACI<sup>30</sup> and 1.4 times the bar diameter or 1.2 in [30 mm] for CSA<sup>31</sup>.
3. A section fails the design if, for any load point the capacity ratio exceeds 1.0 (unless otherwise specified in the Design Criteria dialog box).
4. Once a section passes the design, its capacity is computed and the calculations explained in the procedure for section investigation are performed.
5. For members with large cross-sectional area spColumn sometimes warns the user with the following message “Cannot achieve desired accuracy”. This results when the program cannot meet the predefined convergence criteria and the corresponding point on the interaction diagram may be slightly off. The convergence criteria is more stringent than required in engineering practice, however, the shape of the interaction diagram should be verified to be relatively smooth and free of unexpected discontinuity.

---

<sup>29</sup> The user may select spacing greater than the default value to take into account tolerances for reinforcement placement (see ACI 117-06, Ref [7]) and other project specific considerations.

<sup>30</sup> ACI 318-19, 25.2.3; ACI 318-14, 25.2.3; ACI 318-11, 7.6.3; ACI 318-08, 7.6.3; ACI 318-05, 7.6.3; ACI 318-02, 7.6.3

<sup>31</sup> CSA A23.3-19, Annex A, 6.6.5.2; CSA A23.3-14, Annex A, 6.6.5.2; CSA A23.3-04, Annex A, 6.6.5.2; CSA A23.3-94, Annex A, A12.5.2

### 2.3.3. Moment Magnification at Ends of Compression Member

This procedure accounts for moment magnification due to second-order effects at ends of columns in sway frames<sup>32</sup>.

1. If properties of framing members are input, spColumn computes the effective length factor,  $k_s$ , for sway condition using the following equation<sup>33</sup>:

$$\left[ \frac{(\pi / k_s)^2 \psi_A \psi_B}{36} - 1 \right] \tan \frac{\pi}{k_s} - \left( \frac{\psi_A + \psi_B}{6} \right) \frac{\pi}{k_s} = 0$$

where  $\psi$  is the ratio of  $\sum(EI/\ell_c)$  of columns to  $\sum(EI/\ell)$  of beams in a plane at one end of the column,  $\psi_A$  and  $\psi_B$  are the values of  $\psi$  at the upper end and the lower end of the column. For a hinged end,  $\psi$  is very large. This happens in the case where  $\sum(EI/\ell)$  of beams is very small (or zero) relative to the  $\sum(EI/\ell_c)$  of columns at that end. In this case, the program outputs 999.9 for the value of  $\psi$ . The moment of inertia used in computing  $\psi$  is the gross moment of inertia multiplied by the cracked section coefficients<sup>34</sup> (specified in the Slenderness Factors dialog box).

2. For the ACI code<sup>35</sup>, slenderness effects will be considered if  $k \times l_u / r \geq 22.0$ . For the CSA standards, all sway columns are designed for slenderness effects.

<sup>32</sup> ACI 318-19, 6.6.4.6.1; ACI 318-14, 6.6.4.6.1; ACI 318-11, 10.10.7; ACI 318-08, 10.10.7; ACI 318-05, 10.13; ACI 318-02, 10.13; CSA A23.3-19, 10.16; CSA A23.3-14, 10.16; CSA A23.3-04, 10.16; CSA A23.3-94, 10.16

<sup>33</sup> Exact formula derived in Ref. [14] pp. 851 for Jackson and Moreland alignment chart

<sup>34</sup> ACI 318-19, 6.6.3.1.1, 6.6.4.2, 6.7.1.3, 6.8.1.4; ACI 318-14, 6.6.3.1.1, 6.6.4.2, 6.7.1.3, 6.8.1.4; ACI 318-11, 10.10.4.1; ACI 318-08, 10.10.4.1; ACI 318-05, 10.11.1, 10.13.1; ACI 318-02, 10.11.1, 10.13.1; CSA A23.3-14, 10.14.1.2, 10.16.1; CSA A23.3-19, 10.14.1.2, 10.16.1; CSA A23.3-04, 10.14.1.2, 10.16.1; CSA A23.3-94, 10.14.1, 10.16.1

<sup>35</sup> ACI 318-19, 6.2.5; ACI 318-14, 6.2.5; ACI 318-11, 10.10.1; ACI 318-08, 10.10.1; ACI 318-05, 10.13.2; ACI 318-02, 10.13.2

3. If the ratio  $k \times l_u / r$  exceeds 100, slenderness effects cannot be accounted for using moment magnification procedure<sup>36</sup>. A more exact method must be used. In this case, the program issues a warning message and aborts design or investigation procedure except for calculations per ACI 318-19, ACI 318-14, ACI 318-11, and ACI 318-08 where limit of  $k \times l_u / r < 100$  does not explicitly apply and the program continues calculations after showing the warning message.
4. Factored moments,  $M_{ns,top}$  and  $M_{ns,bot}$ , due to dead, live, and snow loads assumed to cause no appreciable sidesway<sup>37</sup>, are calculated at the top and bottom ends of the column.
5. Factored moments,  $M_{s,top}$  and  $M_{s,bot}$ , due to lateral loads (wind and earthquake) assumed to cause appreciable sidesway<sup>38</sup>, are calculated at the top and bottom ends of the column.

---

<sup>36</sup> ACI 318-05, 10.11.5; ACI 318-02, 10.11.5; CSA A23.3-19, 10.13.2; CSA A23.3-14, 10.13.2; CSA A23.3-04, 10.13.2; CSA A23.3-94, 10.13.2

<sup>37</sup> ACI 318-19, 2.1; ACI 318-14, 2.1; ACI 318-11, 2.1; ACI 318-08, 2.1; ACI 318-05, 2.1; ACI 318-02, 10.0; CSA A23.3-19, 3.2; CSA A23.3-14, 3.2; CSA A23.3-04, 2.3; CSA A23.3-94, 10.0

<sup>38</sup> ACI 318-14, 2.1; ACI 318-11, 2.1; ACI 318-08, 2.1; ACI 318-05, 2.1; ACI 318-02, 10.0; CSA A23.3-04, 2.3; CSA A23.3-94, 10.0

6. Flexural stiffness  $EI$  is calculated as<sup>39</sup>:

$$EI = \frac{0.2E_c I_g + E_s I_{se}}{1 + \beta_{ds}}$$

where  $E_c$  is the modulus of elasticity of concrete,  $E_s$  is the modulus elasticity of steel,  $I_g$  is the gross moment of inertia of the concrete section,  $I_{se}$  is the moment of inertia of reinforcement. Assuming that shear due to lateral loads is not sustained in most frames<sup>40</sup>, the  $\beta_{ds}$  is taken as zero (with the exception of strength and stability of the structure as a whole under factored gravity loads described in Step 11).

7. The critical buckling load,  $P_c$ , is computed as<sup>41</sup>.

$$P_c = \frac{\pi^2 EI}{(k \times l_u)^2}$$

<sup>39</sup> ACI 318-19, 6.6.4.4.4, Eq. 6.6.4.4.4b; ACI 318-14, 6.6.4.4.4, Eq. 6.6.4.4.4b; ACI 318-11, 10.10.6 Eq. 10-14; ACI 318-08, 10.10.6 Eq. 10-14; ACI 318-05, 10.12.3 Eq. 10-11; ACI 318-02, 10.12.3. Eq. 10-10; CSA A23.3-14/19, 10.16.3.2, 10.15.3 Eq. 10-19; CSA A23.3-04, 10.16.3.2, 10.15.3 Eq. 10-18; CSA A23.3-94, 10.16.3.2, 10.15.3.1 Eq. 10-18

<sup>40</sup> ACI 318-19, R6.6.4.6.2(b); ACI 318-14, R6.6.4.6.2(b); ACI 318-11, R10.10.7.4; ACI 318-08, R10.10.7.4; ACI 318-05, R10.13.4.1, R10.13.4.3; ACI 318-02, R10.13.4.1, R10.13.4.3; Ref. [10] pp 586 (first paragraph from the bottom)

<sup>41</sup> ACI 318-19, 6.6.4.4.2, Eq. 6.6.4.4.2; ACI 318-14, 6.6.4.4.2, Eq. 6.6.4.4.2; ACI 318-11, 10.10.6 Eq. 10-13; ACI 318-08, 10.10.6 Eq. 10-13; ACI 318-05, 10.12.3 Eq. 10-10; ACI 318-02, 10.12.3 Eq. 10-10; CSA A23.3-19, 10.16.3.2, 10.15.3.1 Eq. 10-18; CSA A23.3-14, 10.16.3.2, 10.15.3.1 Eq. 10-18; CSA A23.3-04, 10.16.3.2, 10.15.3.1 Eq. 10-17; CSA A23.3-94, 10.16.3.2, 10.15.3 Eq. 10-17

8. The sway moment magnification factor,  $\delta_s$ , is computed as<sup>42</sup>:

$$\delta_s = \frac{1.0}{1 - \frac{\sum P_u}{\phi_k \sum P_c}} \geq 1.0^*$$

where the stiffness reduction factor,  $\phi_k$ , is equal to 0.75.

$\Sigma P_u$  is taken as the factored axial load for the load combination under consideration times the ratio  $\Sigma P_u / P_u$ , i.e.<sup>43</sup>  $\Sigma P_u = P_u (\Sigma P_u / P_u)$ .

$\Sigma P_c$  is taken as the critical buckling load for the load combination under consideration times the ratio  $\Sigma P_c / P_c$ , i.e.  $\Sigma P_c = P_c (\Sigma P_c / P_c)$ .

$\phi_k$  and the ratios  $\Sigma P_u / P_u$  and  $\Sigma P_c / P_c$  may be modified using the Slenderness Factors input box.

9. The magnified moments at the top and bottom ends of the compression member are computed as<sup>44</sup>:

$$M_{top} = M_{ns,top} + \delta_s M_{s,top}$$

$$M_{bot} = M_{ns,bot} + \delta_s M_{s,bot}$$

<sup>42</sup> ACI 318-19, 6.6.4.6.2, Eq. 6.6.4.6.2b; ACI 318-14, 6.6.4.6.2, Eq. 6.6.4.6.2b; ACI 318-11, 10.10.7.4 Eq. 10-21; ACI 318-08, 10.10.7.4 Eq. 10-21; ACI 318-05, 10.13.4.3 Eq. 10-18; ACI 318-02, 10.13.4.3 Eq. 10-18; CSA A23.3-19, 10.16.3.2 Eq. 10-24; CSA A23.3-14, 10.16.3.2 Eq. 10-24; CSA A23.3-04, 10.16.3.2 Eq. 10-23; CSA A23.3-94, 10.16.3.2 Eq. 10-23

\* Corrected  $P_u$  to  $P_c$  (02/20/2026)

<sup>43</sup> To minimize required input, the program uses one value of ratio  $\Sigma P_u / P_u$  for all load combinations. However, the ratio can vary depending on the combination under consideration. In this case, it will be conservative to use the highest value of the ratio.

<sup>44</sup> ACI 318-19, 6.6.4.6.1; ACI 318-14, 6.6.4.6.1; ACI 318-11, 10.10.7; ACI 318-08, 10.10.7; ACI 318-05, 10.13.3; ACI 318-02, 10.13.3; CSA A23.3-19, 10.16.2; CSA A23.3-14, 10.16.2; CSA A23.3-04, 10.16.2; CSA A23.3-94, 10.16.2

10. The smaller and the larger factored end moments are then determined based on absolute values of magnified top and bottom end moments

$$M_1 = \begin{cases} M_{bot} & \text{if } |M_{top}| \geq |M_{bot}|, \\ M_{top} & \text{if } |M_{top}| < |M_{bot}|, \end{cases}$$

$$M_2 = \begin{cases} M_{top} & \text{if } |M_{top}| \geq |M_{bot}|, \\ M_{bot} & \text{if } |M_{top}| < |M_{bot}|, \end{cases}$$

While design codes define moment  $M_2$  as always positive and the sign of moment  $M_1$  depending on single or double curvature bending<sup>45</sup>, spColumn retains actual signs of moments  $M_1$  and  $M_2$ . This revision ensures proper comparison against negative and positive moment capacities of unsymmetrical sections (see [Figure 2.9](#)).

11. Strength and stability of the structure as a whole under factored gravity loads<sup>46</sup> is ensured by checking that the value of the moment magnification factor,  $\delta_s$ , is positive and does not exceed 2.5.

The program performs this check for all load combinations that include only gravity loads with the exception of the ACI 318-19/14/11/08 codes for which the check is not performed and CSA A23.3-94 where the check is performed only for the load combination of 1.25 dead load plus 1.5 live load plus (1.5 snow or 0.0 snow), if this combination is present (default). The  $\beta_d$  factor for the load combination under consideration is equal to the maximum sustained factored axial load to the maximum factored axial load.

<sup>45</sup> ACI 318-14, 2.1; ACI 318-11, 2.1; ACI 318-08, 2.1; ACI 318-05, 2.1; ACI 318-02, 10.0; CSA A23.3-19, 3.2; CSA A23.3-14, 3.2; CSA A23.3-04, 2.3; CSA A23.3-94, 10.0

<sup>46</sup> ACI 318-05, 10.13.6; ACI 318-02, 10.13.6; CSA A23.3-19, 10.16.5; CSA A23.3-14, 10.16.5; CSA A23.3-04, 10.16.5; CSA A23.3-94, 10.16.5

### 2.3.4. Moment Magnification along Length of Compression Member

This procedure accounts for moment magnification due to second-order effect along the length of compression members that are part of either nonsway<sup>47</sup> or sway frames<sup>48</sup>. In nonsway frames, moment magnification along length is neglected by the program if the condition in Step 3 is satisfied.

In sway frames designed per ACI 318-02/05 and CSA A23.3-94/04/14/19, the magnification along the length is neglected if<sup>49</sup>:

$$\frac{l_u}{r} \leq \frac{35}{\sqrt{\frac{P_u}{f'_c A_g}}}$$

By rearranging and introducing,  $k' = \sqrt{P_u / (f'_c A_g)}$  this condition can be succinctly expressed as  $k' \times l_u / r \leq 35$ . For columns designed per ACI 318-19, ACI 318-14, ACI 318-11, and ACI 318-08 codes, moment magnification along length is to be considered for all slender compression members, i.e. columns in either nonsway or sway frames regardless of the  $k' \times l_u / r$  ratio. Since various published examples of columns designed per ACI 318-19, ACI 318-14, ACI 318-11, and ACI 318-08 do not combine moment magnification at ends and along length of columns in sway frames<sup>50</sup>, spColumn optionally allows not considering moment magnification along the length of a column in a sway frame based on engineering judgment of the user.

<sup>47</sup> ACI 318-19, 6.6.4.4.2, 6.6.4.5.1, 6.6.4.5.2; ACI 318-14, 6.6.4.4.2, 6.6.4.5.1, 6.6.4.5.2; ACI 318-11, 10.10.6; ACI 318-08, 10.10.6; ACI 318-05, 10.12; ACI 318-02, 10.12; CSA A23.3-19, 10.15; CSA A23.3-14, 10.15; CSA A23.3-04, 10.15; CSA A23.3-94, 10.15

<sup>48</sup> ACI 318-19, 6.6.1.1; ACI 318-14, 6.6.1.1; ACI 318-11, 10.10.2.2; ACI 318-08, 10.10.2.2; ACI 318-05, 10.13.5; ACI 318-02, 10.13.5; CSA A23.3-19, 10.16.4; CSA A23.3-14, 10.16.4; CSA A23.3-04, 10.16.4; CSA A23.3-94, 10.16.4

<sup>49</sup> ACI 318-05, Eq. 10-19; ACI 318-02, Eq. 10-19; CSA A23.3-04, Eq. 10-26; CSA A23.3-04, Eq. 10-25; CSA A23.3-94, Eq. 10-25

<sup>50</sup> See Example 11.2 in Ref. [11], Example 12.4 in Ref. [13], and Example 12.3 in Ref. [12]

When moment magnification along the length of a compression member is considered, the following procedure is followed:

1. The effective length factor,  $k$ , is either entered by the user or calculated by the program. The value of  $k$  must be between 0.5 and 1.0 for moment magnification along length and the recommended<sup>51</sup> value is 1.0. Smaller values can be used if justified by analysis. If properties of framing members are input, spColumn computes the effective length factor,  $k$ , for nonsway condition from the following equation<sup>52</sup>:

$$\frac{\psi_A \psi_B}{4} \left( \frac{\pi^2}{k^2} \right) + \left( \frac{\psi_A + \psi_B}{2} \right) \left( 1 - \frac{\pi / k}{\tan(\pi / k)} \right) + \frac{2}{\pi / k} \tan \frac{\pi}{2k} = 1$$

Where  $\psi$  is the ratio of  $\sum(EI/\ell_c)$  of columns to  $\sum(EI/\ell)$  of beams in a plane at one end of the column,  $\psi_A$  and  $\psi_B$  are the values of  $\psi$  at the upper end and the lower end of the column, respectively. Moments of inertia used in computing  $\psi$  factors are gross moments of inertia multiplied by the cracked section coefficients<sup>53</sup> (specified in the Slenderness Factors dialog box).

2. Moments at column ends,  $M_1$  and  $M_2$ , are calculated, where  $M_1$  is the moment with the smaller absolute value and  $M_2$  is the moment with the larger absolute value. For columns in nonsway frames, the end moments will be equal to the factored applied first order moment. For columns in sway frames, the end moments will be the moments  $M_1$  and  $M_2$  calculated in the procedure for moment magnification at ends of compression member.

<sup>51</sup> ACI 318-19, 6.6.4.4.3, R6.6.4.4.3; ACI 318-14, 6.6.4.4.3, R6.6.4.4.3; ACI 318-11, 10.10.6.3, R10.10.6.3; ACI 318-08, 10.10.6.3, R10.10.6.3; ACI 318-05, 10.12.1; ACI 318-02, 10.12.1; CSA A23.3-19, 10.15.1; CSA A23.3-14, 10.15.1; CSA A23.3-04, 10.15.1; CSA A23.3-94, 10.15.1

<sup>52</sup> Exact formula derived in Ref. [14] pp. 848 for Jackson and Moreland alignment chart.

<sup>53</sup> ACI 318-19, 6.6.3.1.1, 6.6.4.2, 6.7.1.3, 6.8.1.4; ACI 318-14, 6.6.3.1.1, 6.6.4.2, 6.7.1.3, 6.8.1.4; ACI 318-11, 10.10.4.1; ACI 318-08, 10.10.4.1; ACI 318-05, 10.11.1, 10.12.1; ACI 318-02, 10.11.1, 10.12.1; CSA A23.3-19, 10.14.1.2, CSA A23.3-14, 10.14.1.2, 10.15.1; CSA A23.3-04, 10.14.1.2, 10.15.1; CSA A23.3-94, 10.14.1, 10.15.1

While design codes define moment  $M_2$  as always positive and the sign of moment  $M_1$  depending on single or double curvature bending<sup>54</sup>, spColumn retains actual signs of moments  $M_1$  and  $M_2$  to ensure proper comparison of resulting magnified moments against negative and positive moment capacities of unsymmetrical sections (see [Figure 2.9](#)).

This revised interpretation does not affect results of the moment magnification along length procedure because the procedure relies on the  $M_1/M_2$  ratio. spColumn follows the code definition which assumes the ratio to be positive if the member is bent in single curvature and negative if bent in double curvature. If both moments are equal to zero, the program conservatively assumes the ratio of  $M_1/M_2 = 1.0$ .

3. Second-order effects along length for columns in nonsway frames can be ignored if:

$$\frac{k \times l_u}{r} \leq 34 - 12 \frac{M_1}{M_2} \leq 40 \text{ for ACI codes}^{55},$$

and

$$\frac{k \times l_u}{r} \leq \frac{25 - 10(M_1 / M_2)}{\sqrt{P_f / (f'_c A_g)}}, \text{ for the CSA standards}^{56},$$

where  $l_u$  is the unsupported column length,  $r = \sqrt{I_g / A}$  is the radius of gyration, and the ratio  $M_1/M_2$  is always taken as greater than or equal to  $-0.5$ . (For CSA A23.3-19, if  $M_2$  is less than  $M_{2,min}$  the  $M_1/M_2$  ratio shall be taken as equal to 1.0)

<sup>54</sup> ACI 318-14, 2.1; ACI 318-11, 2.1; ACI 318-08, 2.1; ACI 318-05, 2.1; ACI 318-02, 10.0; CSA A23.3-19, 3.2; CSA A23.3-14, 3.2; CSA A23.3-04, 2.3; CSA A23.3-94, 10.0

<sup>55</sup> ACI 318-19, 6.2.5.1; ACI 318-14, 6.2.5; ACI 318-11, 10.10.1; ACI 318-08, 10.10.1; ACI 318-05, 10.12.2; ACI 318-02, 10.12.2

<sup>56</sup> CSA A23.3-19, 10.15.2; CSA A23.3-14, 10.15.2; CSA A23.3-04, 10.15.2; CSA A23.3-94, 10.15.2

4. If the ratio  $k \times l_u / r$  exceeds 100, slenderness effects cannot be accounted for using moment magnification procedure<sup>57</sup>. A more exact method must be used. In this case, the program issues a warning message and aborts design or investigation procedure except for calculations per ACI 318-19, ACI 318-14, ACI 318-11, and ACI 318-08 where limit of  $k \times l_u / r < 100$  does not explicitly apply and the program continues calculations after showing the warning message.
5. The factor  $C_m$  is computed as<sup>58</sup>:

$$C_m = 0.6 + 0.4 \frac{M_1}{M_2}$$

and for codes other than ACI 318-19, ACI 318-14, ACI 318-11, and ACI 318-08,  $C_m$  is taken as not less than 0.4.

If  $M_1 = M_2 = 0$ , the program assumes  $C_m$  to be equal to 1.0<sup>59</sup>. This is consistent with the assumption made above (in Step 2).

For CSA A23.3-19, if  $M_{2,min}$  exceeds  $M_2$ ,  $C_m$  shall be taken as equal to 1.0<sup>60</sup>.

<sup>57</sup> ACI 318-05, 10.11.5; ACI 318-02, 10.11.5; CSA A23.3-14, 10.13.2; CSA A23.3-04, 10.13.2; CSA A23.3-94, 10.13.2

<sup>58</sup> ACI 318-19, 6.6.4.5.3; ACI 318-14, 6.6.4.5.3; ACI 318-11, 10.10.6.4; ACI 318-08, 10.10.6.4; ACI 318-05, 10.12.3.1; ACI 318-02, 10.12.3.1; CSA A23.3-19, 10.15.3.2; CSA A23.3-14, 10.15.3.2; CSA A23.3-04, 10.15.3.2; CSA A23.3-94, 10.15.3.1

<sup>59</sup> ACI 318-19, 6.6.4.5.4; ACI 318-14, 6.6.4.5.4; ACI 318-11, 10.10.6.5; ACI 318-08, 10.10.6.5; ACI 318-05, 10.12.3.2; ACI 318-02, 10.12.3.2

<sup>60</sup> CSA A23.3-19, 10.15.3.1

6. The sustained load factor  $\beta_{dns}$  ( $\beta_d$  for ACI 318-05/02 and CSA A23.3-14/04/94) is computed as the ratio of maximum factored axial sustained load to the maximum factored axial load for the load combination under consideration for compression members either in nonsway<sup>61</sup> or sway<sup>62</sup> frames. The value of  $\beta_{dns}$  is not taken greater than 1.0.
7. Flexural stiffness  $EI$  is computed as<sup>63</sup>:

$$EI = \frac{0.2E_c I_g + E_s I_{se}}{1 + \beta_{dns}}$$

where  $E_c$  is the modulus of elasticity of concrete,  $E_s$  is the modulus of elasticity of steel,  $I_g$  is the gross moment of inertia of the concrete section, and  $I_{se}$  is the moment of inertia of reinforcement.

8. The critical buckling load,  $P_c$  is computed as<sup>64</sup>:

$$P_c = \frac{\pi^2 EI}{(k \times l_u)^2}$$

<sup>61</sup> ACI 318-19, 6.6.4.4.4; ACI 318-14, 6.6.4.4.4; ACI 318-11, 10.10.6.2; ACI 318-08, 10.10.6.2; ACI 318-05, 10.11.1; ACI 318-02, 10.0; CSA A23.3-19, 3.2; CSA A23.3-14, 3.2; CSA A23.3-04, 2.3; CSA A23.3-94, 10.0

<sup>62</sup> ACI 318-19, 6.6.1.1; ACI 318-14, 6.6.1.1; ACI 318-11, 10.10.2.2, 10.10.6.2; ACI 318-08, 10.10.2.2, 10.10.6.2; ACI 318-05, 10.13.5; ACI 318-02, 10.13.5; CSA A23.3-19, 10.14.1.3(a), 10.16.4; CSA A23.3-14, 10.14.1.3(a), 10.16.4; CSA A23.3-04, 10.14.1.3(a), 10.16.4; CSA A23.3-94,  $\beta_d$  definition (a) in 10.0, 10.16.4

<sup>63</sup> ACI 318-19, 6.6.4.4.4, Eq. 6.6.4.4.4b; ACI 318-14, 6.6.4.4.4, Eq. 6.6.4.4.4b; ACI 318-11, 10.10.6.1, Eq. 10-14; ACI 318-08, 10.10.6.1 Eq. 10-14; ACI 318-05, 10.12.3 Eq. 10-11; ACI 318-02, 10.12.3 Eq. 10-10; CSA A23.3-19, 10.15.3 Eq. 10-19; CSA A23.3-14, 10.15.3.1 Eq. 10-19; CSA A23.3-04, 10.15.3.1 Eq. 10-18; CSA A23.3-94, 10.15.3.1 Eq. 10-18.

<sup>64</sup> ACI 318-19, 6.6.4.4.2, Eq. 6.6.4.4.2; ACI 318-14, 6.6.4.4.2, Eq. 6.6.4.4.2; ACI 318-11, 10.10.6 Eq. 10-13; ACI 318-08, 10.10.6 Eq. 10-13; ACI 318-05, 10.12.3 Eq. 10-10; ACI 318-02, 10.12.3 Eq. 10-10; CSA A23.3-19, 10.15.3.1 Eq. 10-18; CSA A23.3-14, 10.15.3.1 Eq. 10-18; CSA A23.3-04, 10.15.3.1 Eq. 10-17; CSA A23.3-94, 10.15.3 Eq. 10-17

9. The magnification factor for moment along length,  $\delta$ , is computed as<sup>65</sup>:

$$\delta = \frac{C_m}{1 - \frac{P_u}{\phi_k \times P_c}}$$

where the stiffness reduction factor,  $\phi_k$ , is equal to 0.75 (may be modified using the Slenderness Factors input box) and  $P_u$  is the factored axial load for the load combination under consideration.

10. The moment due to minimum eccentricity,  $e_{min}$  is computed as<sup>66</sup>:

$$M_{min} = P_u \times e_{min}, \text{ where}$$

$$e_{min} = 0.6 + 0.03h, \text{ with } h \text{ in inches,}$$

$$e_{min} = 15 + 0.03h, \text{ with } h \text{ in mm,}$$

and  $h$  is the section dimension (diameter for circular sections) in the direction being considered.

<sup>65</sup> ACI 318-19, 6.6.4.5.2 Eq. 6.6.4.5.2; ACI 318-14, 6.6.4.5.2 Eq. 6.6.4.5.2; ACI 318-11, 10.10.6 Eq. 10-12; ACI 318-08, 10.10.6 Eq. 10-12; ACI 318-05, 10.12.3 Eq. 10.9; ACI 318-02, 10.12.3 Eq. 10.9; CSA A23.3-19, 10.15.3.1 Eq. 10-17; CSA A23.3-14, 10.15.3.1 Eq. 10-17; CSA A23.3-04, 10.15.3.1 Eq. 10-16; CSA A23.3-94, 10.15.3 Eq. 10-16.

<sup>66</sup> ACI 318-19, 6.6.4.5.4; ACI 318-14, 6.6.4.5.4; ACI 318-11, 10.10.6.5; ACI 318-08, 10.10.6.5; ACI 318-05, 10.12.3.2; ACI 318M-05, 10.12.3.2; ACI 318-02, 10.12.3.2; ACI 318M-02 10.12.3.2; CSA A23.3-19, 10.15.3.1; CSA A23.3-14, 10.15.3.1; CSA A23.3-04, 10.15.3.1; CSA A23.3-94, 10.15.3.

11. The factored magnified moment along the length of a compression member,  $M_c$ , is the larger<sup>67</sup> of  $\delta M_2$  and  $\delta M_{min}$ . The program also calculates moment  $M_c$  based on the smaller end moment,  $M_1$ , to account for scenario when  $M_1$  and  $M_2$  are of different sign (double curvature bending). For an unsymmetrical section, the smaller moment,  $M_1$ , may govern the design when the moment capacity on the negative side of the interaction diagram is smaller than the moment capacity on the positive side (see [Figure 2.9](#)).

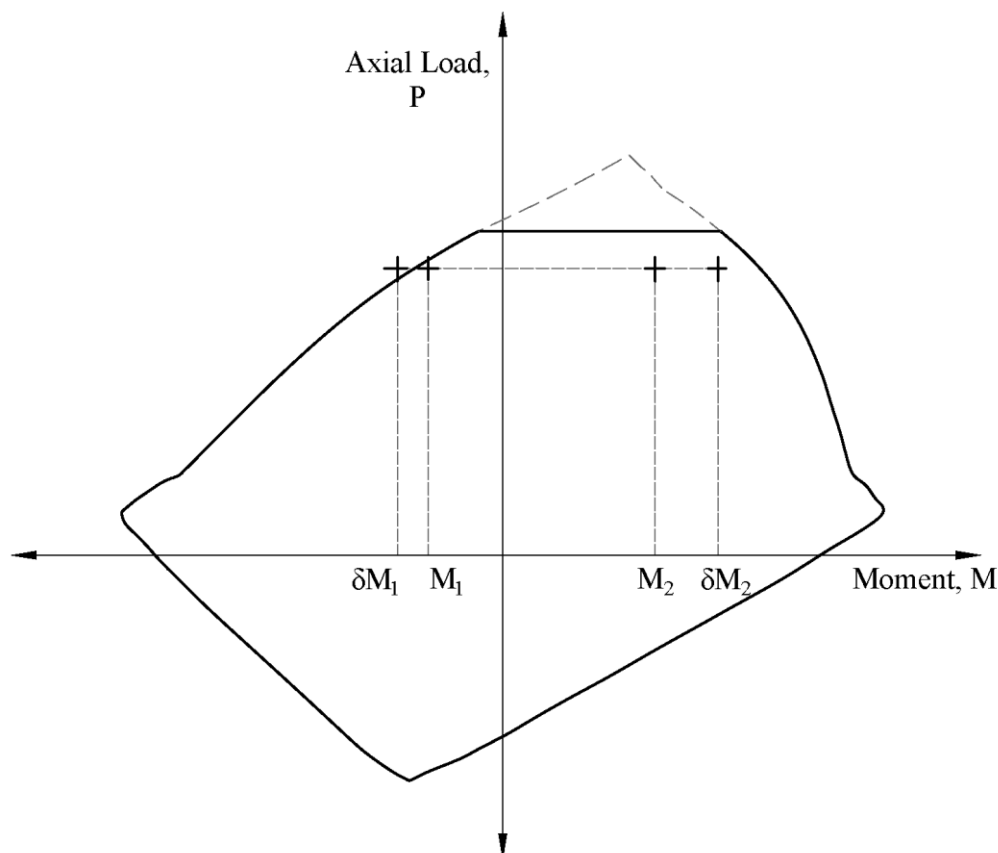

Figure 2.9 – Case of unsymmetrical section bent in double curvature ( $M_1$  and  $M_2$  of different sign) with the smaller end moment,  $M_1$ , governing the design

<sup>67</sup> ACI 318-19, 6.6.4.5.4; ACI 318-14, 6.6.4.5.4; ACI 318-11, 10.10.6.5; ACI 318-08, 10.10.6.5; ACI 318-05, 10.12.3.2; ACI 318-02, 10.12.3.2; CSA A23.3-19, 10.15.3.1; CSA A23.3-14, 10.15.3.1; CSA A23.3-04, 10.15.3.1; CSA A23.3-94, 10.15.3

### 2.3.5. Moments Magnification Ratio

For calculations in accordance with ACI 318-19/14/11/08, the value of total magnified moment including second-order effects (combined magnification at ends and along length of compression member) cannot exceed 1.4 times the corresponding moment due to first order effects<sup>68</sup>. Columns with second-order moment to first-order moment ratios exceeding 1.4 do not meet requirements of ACI 318-19/14/11/08.

The ratio of second-order moment,  $M_{2nd}$ , to first-order moment  $M_{1st}$  is calculated for both values ( $i = 1, 2$ ) of magnified moment along length,  $M_{ci}$ , i.e. based on  $M_1$  and  $M_2$ :

$$\frac{M_{2nd_i}}{M_{1st_i}} = \begin{cases} \frac{M_{c_i}}{M_{u_i}} & \text{if } |M_{u_i}| < |M_{min}| \\ \frac{M_{c_i}}{M_{min}} & \text{if } |M_{u_i}| < |M_{min}| \end{cases}$$

Cut off value of  $M_{min}$  is applied to  $M_{ui}$  in order to avoid unduly large ratios in cases where  $M_{ui}$  moments are smaller than  $M_{min}$ .

<sup>68</sup> ACI 318-19, 6.2.5.3; ACI 318-14, 6.2.6; ACI 318-11, 10.10.2.1; ACI 318-08, 10.10.2.1

If only magnification at ends is considered (i.e. when user chooses to bypass provision 10.10.2.2 of ACI 318-11/08 and provision 6.6.4.6.4 of ACI 318-19/14 and ignores second order effects along the length of a compression member in a sway frame), the ratio of second-order moment,  $M_{2nd}$ , to first-order moment,  $M_{1st}$ , is calculated at both ends ( $i = 1, 2$ ) as:

$$\frac{M_{2nd_i}}{M_{1st_i}} = \frac{M_i}{M_{u_i}} = \frac{M_{ins} + \delta_s M_{is}}{M_{ins} + M_{is}}$$

where  $M_i$  are the magnified end moments  $M_1$  and  $M_2$ , and  $M_{ui}$  are the corresponding factored applied moment composed of the part that causes no appreciable sidesway,  $M_{ins}$ , and the part that causes appreciable sidesway,  $M_{is}$ . If both  $M_{2nd_i}$  and  $M_{1st_i}$  moments are equal to zero, the program will report the ratio equal to 1.0. If only  $M_{1st_i}$  moment is equal to zero, the program will report the ratio as a large value.

## 2.4. Design Methods

---

For any modeled section solved using design or investigation mode, the program computes a Demand Capacity Ratio (DCR), sometimes also referred to as design capacity ratio, for all load points. For biaxial run option the demand capacity ratio for any load point is always computed at the same angles as that produced by the applied  $M_x$  and  $M_y$  moments of that load point.

The DCR in spColumn is computed using one of two methods available for the user to choose from when selecting the project general design criteria. Each method is described in this section to explain the benefits of each to the evaluation by the user of the suitability of section capacity to the intended loading demands.

### 2.4.1. Moment Capacity Method

In the Moment Capacity Method, the program calculates the DCR for a load point considering a factored axial value and compare the moments as follows:

$$\text{Capacity Ratio} = \frac{M_u}{\phi M_n}$$

Sometimes the value of  $\phi M_n$  cannot be obtained. In such cases the program reports a Capacity ratio of “< 1” for load points inside the failure surface and a Capacity ratio of “> 1” for load points outside the failure surface.

In the moment capacity method, the reported capacity ratio can be interpreted as follows:

- |                    |  |
|--------------------|--|
| Capacity ratio < 1 | : internal load-point (capacity is adequate) |
| Capacity ratio = 1 | : load point on diagram                      |
| Capacity ratio > 1 | : external load point (capacity is exceeded) |

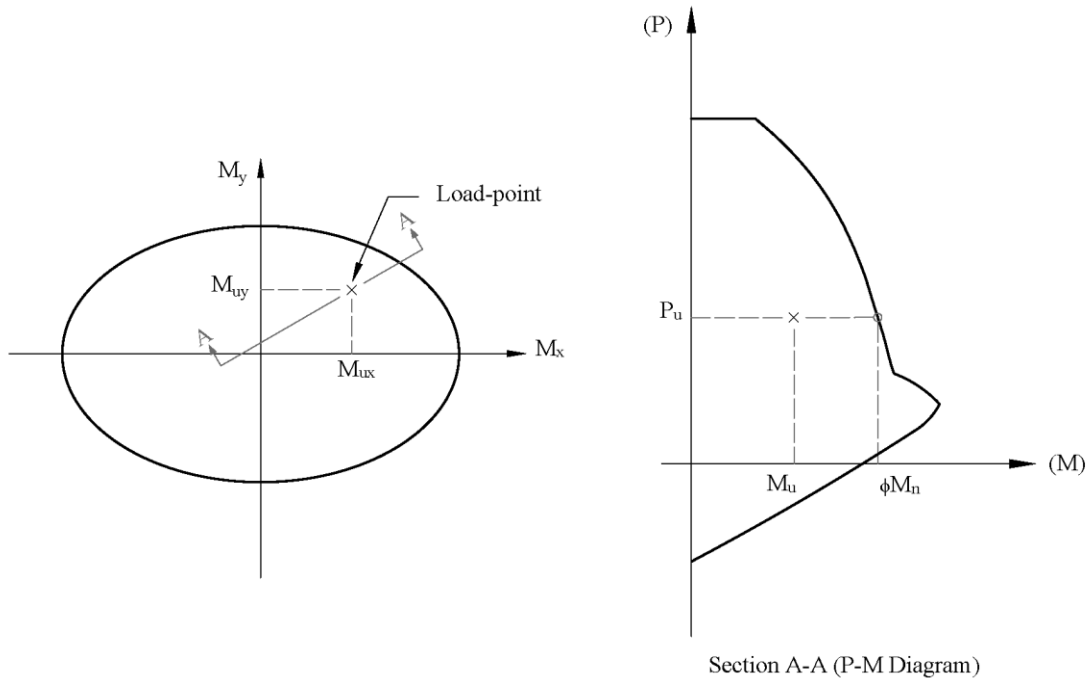

Figure 2.10 – DCR Biaxial Bending  $M_x$ - $M_y$  Diagram and P-M Interaction Diagrams

### 2.4.2. Critical Capacity Method

Introduced by StructurePoint starting with Version 6.50, the critical capacity method is an alternate or secondary method to evaluate section strength. The capacity ratio calculated using this method can be viewed as a “Vulnerability Index” that examines often unseen or hard to visualize conditions leading to a much lower margin of safety for a particular modeled section.

The capacity ratio calculation is based on the closest distance ( $d$ ) of a load-point from the interaction diagram. But because the horizontal axis ( $M$ ) & vertical axis ( $P$ ) of P-M diagrams have different units and scales, spColumn uses a normalized diagram for the calculation of closest distance ( $d$ ).

The normalized diagram is created by:

Dividing all “ $P$ ” components of diagram-points and load-points by  $P_{max}$

Dividing all “ $M$ ” components of diagram-points and load-points by  $M_{max}$

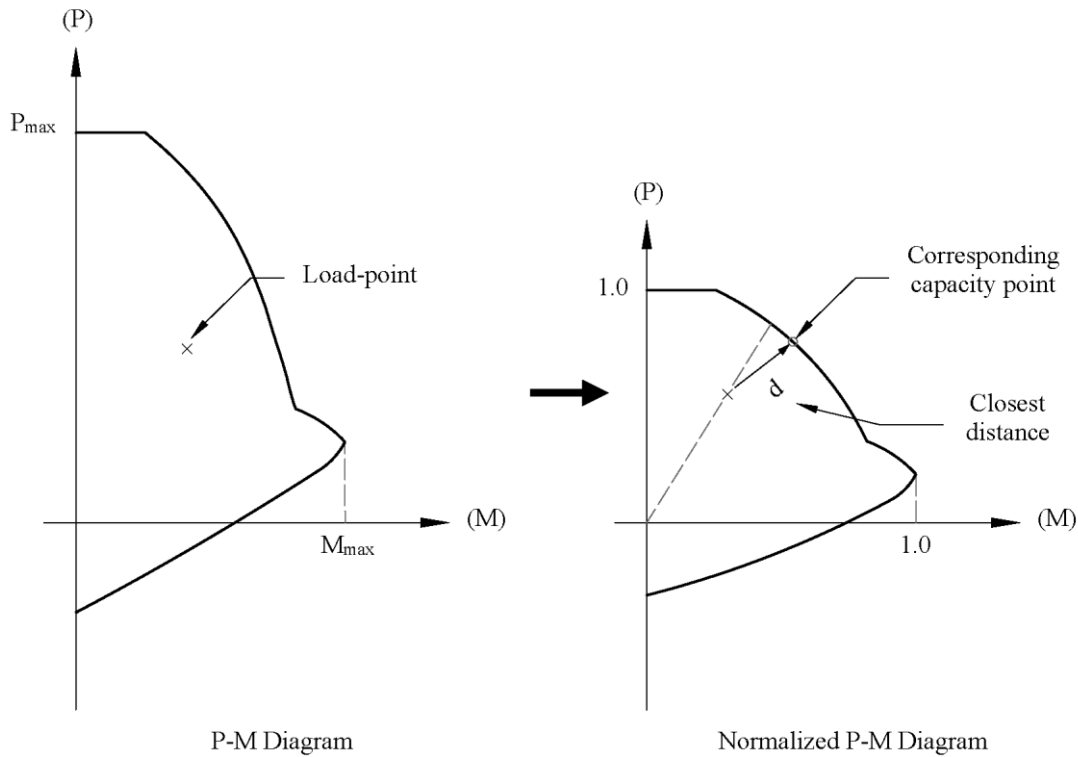

Figure 2.11 – Critical Capacity Method – P-M Diagram vs Normalized P-M Diagram

And the Critical capacity ratio of a load-point is:

Capacity ratio =  $1 - d$  : internal load-point (capacity is adequate)

Capacity ratio = 1 : load point on diagram

Capacity ratio =  $1 + d$  : external load point (capacity is exceeded)

The closest distance ( $d$ ) can alternatively be calculated by finding the corresponding capacity point ( $\phi P_n, \phi M_n$ ) on the diagram which minimizes the following equation:

$$d = \sqrt{\left(\frac{\phi P_n - P_u}{P_{\max}}\right)^2 + \left(\frac{\phi M_n - M_u}{M_{\max}}\right)^2}$$

Additional discussion concerning DCR determination is provided in this article:

[Column Section Demand-Capacity Ratio Determination](#)

## 2.5. Detailing Provisions

---

It is imperative to ensure the final design section is detailed to reflect all the assumptions and inputs used in the structural section model to ensure the calculated capacity can be achieved. Direct detailing requirement of longitudinal and transverse reinforcement in a structural section is not provided by spColumn. The program input and output must be utilized to complete the detailing of final design section.

Confinement choices selected by the user dictate the reduction factors for tied, spiral, and user defined types. User must ensure the final designed section is detailed correctly on design drawings in accordance with the corresponding provisions for confinement in the selected code to match the assumptions made in the model.

Concrete cover to longitudinal and transverse reinforcement used in the model should be reflected in the structural drawings based on the input to reflect the calculated design capacity.

Where slenderness is considered in a model and theoretical end conditions are used, special care must be used to ensure the structural drawings details reflect the assumed end condition used to arrive at the model results and corresponding strength and demand capacity ratios.

### 2.5.1. Lap Splice Requirements

Frequently, the basic gravity load combination will govern the design of the column itself, but a load combination including lateral effects may induce greater tension in some column bars. Each bar splice should be designed for the maximum calculated bar tensile force<sup>69</sup>.

Lap splices are permitted in column reinforcing bars subject to compression or tension. The type of lap splice to be used depends on the bar stress at the splice location, compression or tension, and magnitude if tension, due to all factored load combinations considered in the design of the column. Lap splice type to be used will be governed by the load combination producing the greatest amount of tension in the reinforcing bars being spliced. The design requirements for lap splices in column bars can be illustrated by a typical column interaction diagram as shown in the following figure.

---

<sup>69</sup> ACI 318-19, R10.7.5.1.2;

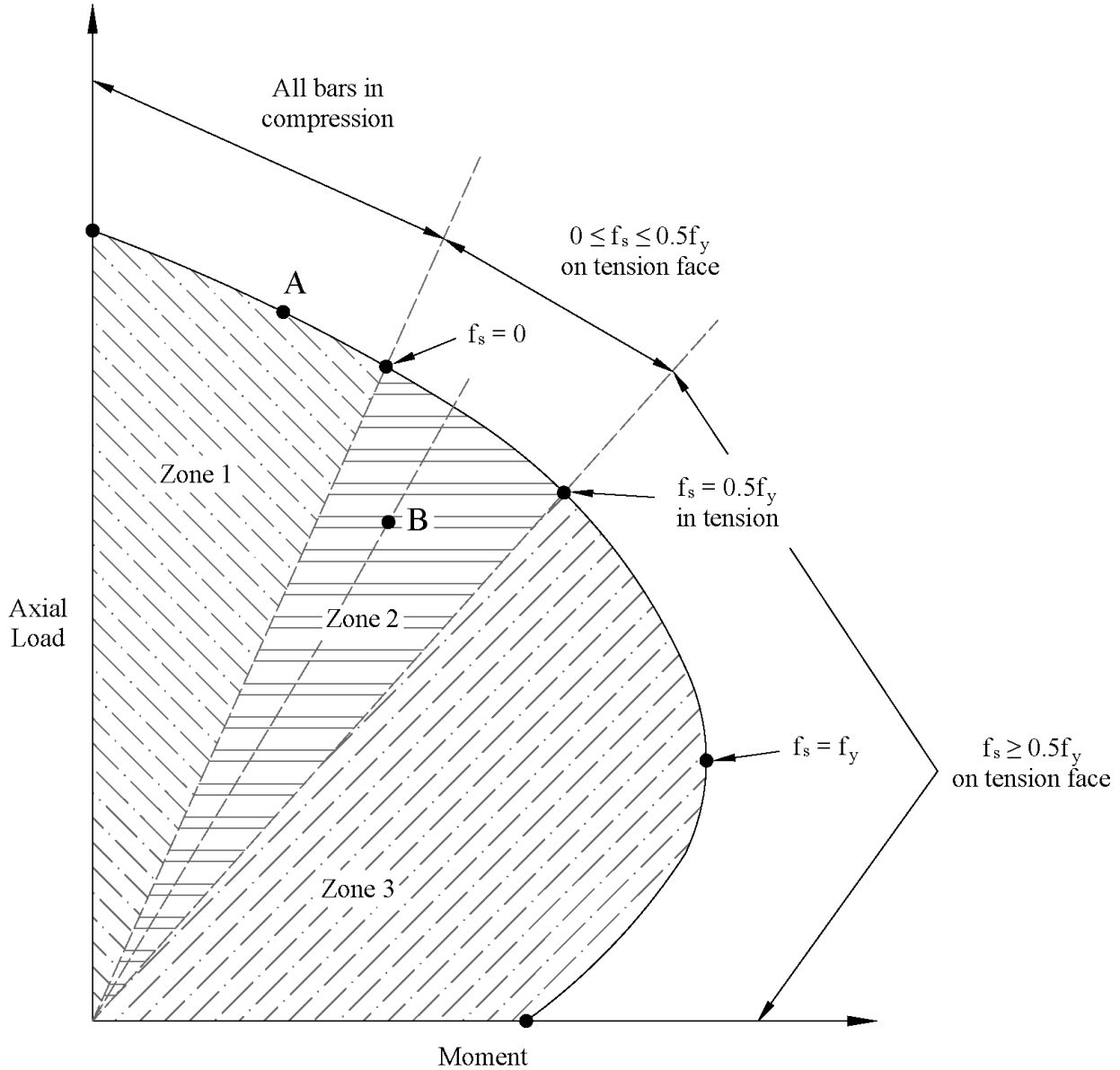

Figure 2.12 – Special Splice Requirements for Columns per Bar Stress

Bar stress at various locations along the column interaction diagram define segments of the strength curve where the different types of lap splices may be used. For factored load combinations along the interaction diagram, bar stress can be readily calculated to determine the type of lap splice required. However, a design dilemma exists for load combinations that do not fall exactly on the interaction diagram (inside the interaction diagram) as there is no simple exact method to calculate bar stress for this condition.

A seemingly rational approach is to consider factored load combinations inside the interaction diagram as producing bar stress of the same type, compression or tension, and of the same approximate magnitude as that produced along the segment of the interaction diagram intersected by radial lines (lines of equal eccentricity) through the load combination point<sup>70</sup>. This assumption becomes more exact as the factored load combinations being investigated fall nearer to the actual strength interaction diagram of the column. Using this approach, zones of “bar stress” can be established as shown in the Figure above.

For factored load combinations in Zone 1, all column bars are considered to be in compression<sup>71</sup>. For load combinations in Zone 2 of the figure, bar stress on the tension face of the column is considered to vary from zero to  $0.5f_y$  in tension<sup>72</sup>. For load combinations in Zone 3, bar stress on the tension face is considered to be greater than  $0.5f_y$  in tension<sup>73</sup>. Type of lap splice to be used will then depend on which zone, or zones, all factored load combinations considered in the design of the column are located. The designer need only locate the factored load combinations on the interaction diagram for the column and bars selected in the design to determine type of lap splice required. Use of the interaction diagram in this manner will greatly facilitate the design of column bar splices.

---

<sup>70</sup> ACI 318-19, 10.7.5; ACI 318-14, 10.7.5; ACI 318-11, 12.17; CSA A23.3-19, 12.17; CSA A23.3-14, 12.17; CSA A23.3-04, 12.17

<sup>71</sup> ACI 318-19, 10.7.5.2.1; ACI 318-14, 10.7.5.2.1; ACI 318-11, 12.17.2.1; CSA A23.3-19, 12.17.3.1; CSA A23.3-14, 12.17.3.1; CSA A23.3-04, 12.17.3.1

<sup>72</sup> ACI 318-19, 10.7.5.2.2; ACI 318-14, 10.7.5.2.2; ACI 318-11, 12.17.2.2; CSA A23.3-19, 12.17.3.2; CSA A23.3-14, 12.17.3.2; CSA A23.3-04, 12.17.3.2

<sup>73</sup> ACI 318-19, 10.7.5.2.2; ACI 318-14, 10.7.5.2.2; ACI 318-11, 12.17.2.3; CSA A23.3-19, 12.17.3.3; CSA A23.3-14, 12.17.3.3; CSA A23.3-04, 12.17.3.3

## 2.6. Special Topics

---

### 2.6.1. High Strength Reinforcing Bars (HSRB)

High Strength Reinforcing Bars (HSRB) are permitted in spColumn with steel tension capacity up to 80 ksi. Steel bars with higher capacity than 80 ksi and up to 100 ksi are permissible in some design standards and will be supported in future versions of spColumn. The user is urged to exercise special care if non standard material properties are used in the input to ensure results are suitably compliant with building code provisions as little or no guidance is adopted for reinforcing steel strength above 100 ksi.

The following technical articles provide some background for HSRB and special considerations for using HSRB in structural members with combined axial and bending. Special observations are outlined in each article highlighting the impact of new ACI 318-19 provisions are by utilizing a simple design example.

[Column Design Capacity Comparison with High Strength Reinforcing Bars per ACI 318-14 and ACI 318-19](#)

[Column Design with High-Strength Reinforcing Bars per ACI 318-19](#)

## 2.6.2. Effective Flexural Stiffness

A primary concern in calculating the critical axial buckling load  $P_c$  is the choice of the stiffness that reasonably approximates the variation in stiffness due to cracking, creep, and concrete nonlinearity.  $(EI)_{eff}$  is used in the process of determining the moment magnification at column ends and along the column length in sway and nonsway frames.  $(EI)_{eff}$  can be calculated as<sup>74</sup>:

$$(EI)_{eff} = \left\{ \begin{array}{l} \text{(a)} \quad \frac{0.4E_c I_g}{1 + \beta_{dns}} \\ \text{(b)} \quad \frac{0.2E_c I_g + E_s I_{se}}{1 + \beta_{dns}} \\ \text{(c)} \quad \frac{E_c I}{1 + \beta_{dns}} \end{array} \right\}$$

The designer may utilize any of the three options for  $(EI)_{eff}$  given the available input data at a given design stage and the desired level of accuracy. spColumn Program utilizes Equation (b)<sup>75</sup> which is more accurate than Equation (a)<sup>76</sup> and less accurate (but less complex) than Equation (c)<sup>77</sup>. The designer may choose between Equations (a) and (b) to optimize the required moment magnification and finalize column size and reinforcement. More information about this topic can be found in the following technical article:

[Effective Flexural Stiffness for Critical Buckling Load of Concrete Columns](#)

<sup>74</sup> ACI 318-19, 6.6.4.4.4; ACI 318-14, 6.6.4.4.4; ACI 318-11, 10.10.6.1; CSA A23.3-19, 10.15.3.1; CSA A23.3-14, 10.15.3.1; CSA A23.3-04, 10.15.3.1

<sup>75</sup> ACI 318-19, 6.6.4.4.4, Eq. 6.6.4.4.4(b); ACI 318-14, 6.6.4.4.4, Eq. 6.6.4.4.4(b); ACI 318-11, 10.10.6.1, Eq. 10-14; CSA A23.3-19, 10.15.3.1, Eq. 10-19; CSA A23.3-14, 10.15.3.1, Eq. 10-19; CSA A23.3-04, 10.15.3.1, Eq. 10-18

<sup>76</sup> ACI 318-19, 6.6.4.4.4, Eq. 6.6.4.4.4(a); ACI 318-14, 6.6.4.4.4, Eq. 6.6.4.4.4(a); ACI 318-11, 10.10.6.1, Eq. 10-15; CSA A23.3-19, 10.15.3.1, Eq. 10-20; CSA A23.3-14, 10.15.3.1, Eq. 10-20; CSA A23.3-04, 10.15.3.1, Eq. 10-19

<sup>77</sup> ACI 318-19, 6.6.4.4.4, Eq. 6.6.4.4.4(c); ACI 318-14, 6.6.4.4.4, Eq. 6.6.4.4.4(c); ACI 318-11, 10.10.6.1

### 2.6.3. CSA Minimum Moment Provisions

CSA provisions for minimum moment,  $M_{2,min}$ , effects on slenderness calculations for non-sway columns per CSA A23.3 has gone through significant changes in the 2004, 2014, and 2019 code cycles. The 2019 edition of CSA A23.3 introduced significant conservatism to non-sway column designs in both slenderness consideration and the moment magnification phases. This article outlines and discusses the evolution of CSA A23.3 in slenderness calculations for non-sway columns where the largest first-order moment,  $M_2$ , is less than the minimum moment,  $M_{2,min}$ . More information about this topic can be found in the following technical article:

[Effects of  \$M\_{2,min}\$  on Slenderness Calculations for Non-Sway Column per CSA A23.3](#)

#### 2.6.4. Bundled Reinforcement Bars

Bundled bars used in large cross sections are frequently encountered in design. In spColumn, bundled bar configurations are treated as irregular reinforcement patterns which can only be run in Investigation mode. However, the program allows the user to define a fictitious bar size under User-defined Bar Set in the define menu instead of using irregular reinforcement pattern. This option also allows the user to utilize the “Design” mode to arrive at the optimal bundled bar configuration.

Definitions
✕

**Properties**

- Concrete
- Reinforcing Steel
- Reduction Factors
- Design Criteria
- Bar Set

**Load Case/Combo.**

- Load Cases
- Load Combinations

### Reinforcement

Bar set: User-defined

+ New
✕ Delete
Import / Export ...

	-	mm	mm <sup>2</sup>	kg/m	
1	#8	8	50.3	0.394	
2	#10	10	78.5	0.616	
3	#12	12	113.1	0.888	
4	#16	16	201.1	1.578	
5	#20	20	314.2	2.466	
6	#25	25	490.9	3.853	
7	#28	28	615.8	4.834	
8	#32	32	804.3	6.313	
9	#36	36	1017.9	7.99	
10	#40	40	1256.6	9.865	
11	#45	45	1608.6	12.626	
12	#50	50	1963.5	15.413	
13	#55	55	2412.9	18.939	
14	#64	64	3217.2	25.252	

OK
Cancel

---

## 2.7. References

---

- [1] Building Code Requirements for Structural Concrete (ACI 318-19) and Commentary (ACI 318R-19), American Concrete Institute, 2019
- [2] Building Code Requirements for Structural Concrete (ACI 318-14) and Commentary (ACI 318R-14), American Concrete Institute, 2014
- [3] Building Code Requirements for Structural Concrete (ACI 318-11) and Commentary (ACI 318R-11), American Concrete Institute, 2011
- [4] Building Code Requirements for Structural Concrete (ACI 318-08) and Commentary (ACI 318R-08), American Concrete Institute, 2008
- [5] Building Code Requirements for Structural Concrete (ACI 318-05) and Commentary (ACI 318R-05), American Concrete Institute, 2005
- [6] Building Code Requirements for Structural Concrete (ACI 318-02) and Commentary (ACI 318R-02), American Concrete Institute, 2002
- [7] Specification for Tolerances for Concrete and Materials and Commentary, An ACI Standard (ACI 117-06), American Concrete Institute, 2006
- [8] CSA23.3-04, Design of Concrete Structures, Canadian Standards Association, 2004
- [9] CSA23.3-94, Design of Concrete Structures, Canadian Standards Association, 1994 (Reaffirmed 2000)
- [10] National Building Code of Canada 2005, Volume 1, Canadian Commission on Buildings and Fire Codes, National Research Council of Canada, 2005
- [11] Notes on ACI 318-08 Building Code Requirements for Structural Concrete with Design Applications, Edited by Mahmoud E. Kamara, Lawrence C. Novak and Basile G. Rabbat, Portland Cement Association, 2008

- [12] Wight J.K. and MacGregor J.G., Reinforced Concrete, Mechanics and Design, Fifth Edition, Pearson Prentice Hall, 2009
- [13] Hassoun M.N. and Al-Manaseer A., Structural Concrete Theory and Design, Fourth Edition, John Wiley & Sons, Inc., 2009
- [14] Salomon C.G. and Johnson J.E., Steel Structures: Design and Behavior, 2nd Edition, Harper & Row Publishers, 1980
- [15] Notes on ACI 318-11 Building Code Requirements for Structural Concrete with Design Applications, Edited by Mahmoud E. Kamara, and Lawrence C. Novak, Portland Cement Association, 2013
- [16] CSA23.3-14, Design of Concrete Structures, Canadian Standards Association, 2014
- [17] National Building Code of Canada 2010, Volume 1, Canadian Commission on Buildings and Fire Codes, National Research Council of Canada, 2010
- [18] CSA23.3-19, Design of Concrete Structures, Canadian Standards Association, 2019

CHAPTER

3

## PROGRAM INTERFACE

---

### 3.1. Start Screen

---

When the Program is launched, a start screen appears as shown below. The Start Screen consists of options to start **New Project**, **Open** existing **Project**, open **Examples** folder, links to available program **Resources** and a list of **Recent** files. The program name and copyright information are located in the bottom right of the start screen. Clicking the **Settings** icon in the bottom-left corner of the start screen opens the SETTINGS dialog, where you can adjust various program settings.

The screenshot shows the spColumn software interface. The window title is "spColumn - Untitled". The interface is divided into three main sections: "Projects", "Resources", and "Recent".

- Projects:** Contains three options: "New project", "Open project", and "Examples".
- Recent:** Lists three recent projects with their file paths:
  - Rectangular Bridge Pier Tied Uniaxial.colx**  
C:\Program Files (x86)\StructurePoint\spColumn\Examples\Examples-Regular
  - Square Bridge Pier Rounded.colx**  
C:\Program Files (x86)\StructurePoint\spColumn\Examples\Examples-Irregular
  - Clover Shaped Column.colx**  
C:\Program Files (x86)\StructurePoint\spColumn\Examples\Examples-Irregular
- Resources:** Contains several links: "Manual...", "Design Examples...", "Tutorial Videos..." (with a video player icon), "spColumn Info...", "Submit a Question...", "Check for Updates...", "Release Notes...", and "About spColumn".

At the bottom of the interface, there is a "Clear all history" button on the left and a copyright notice on the right: "spColumn v10.20 (TM) Copyright © 1988-2025, STRUCTUREPOINT, LLC."

## 3.2. Main Program Window

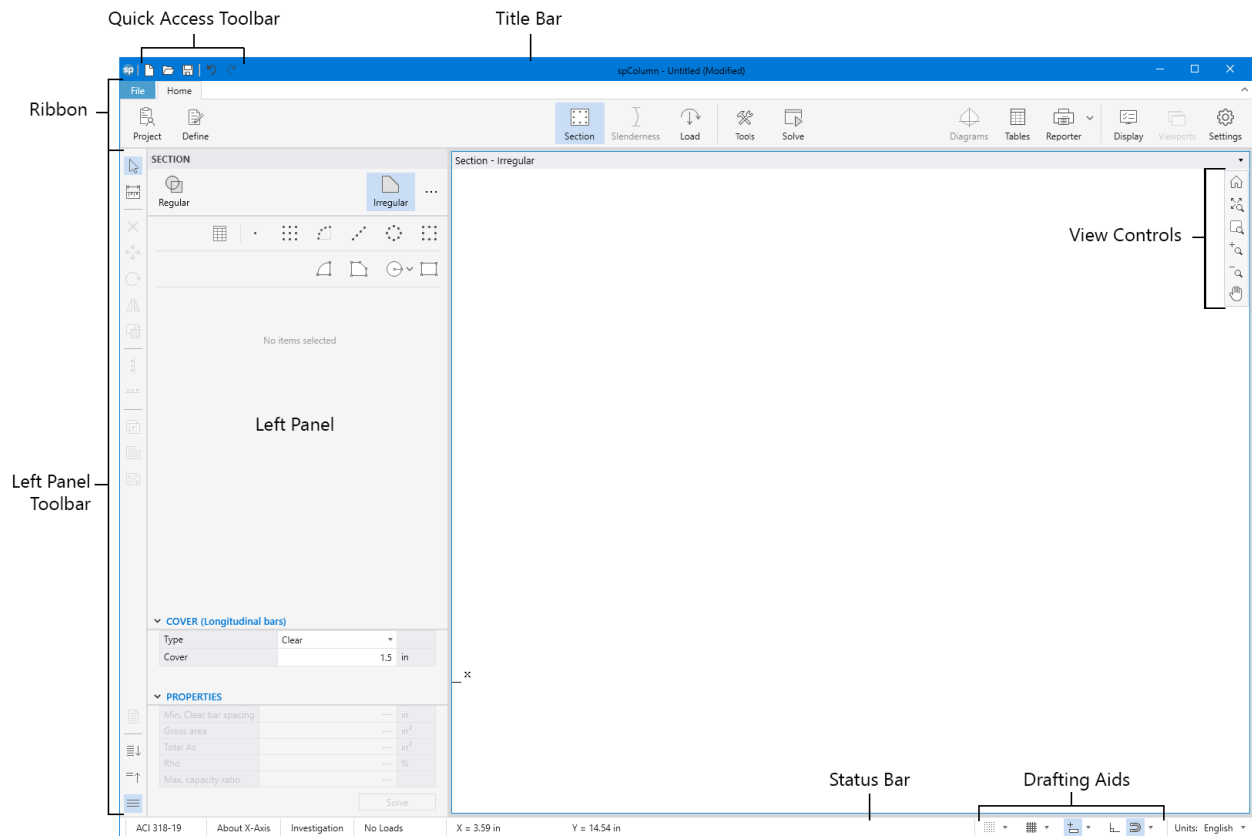

The **Main Program Window** shown above consists of the following:

### Quick Access Toolbar

The **Quick Access Toolbar** includes **New**, **Open**, **Save** and **Undo** and **Redo** commands.

### Title Bar

The Title Bar displays the name of the program, along with the filename of the current data file in use. If the file is new and has not yet been saved, the word “Untitled” is displayed in the **Title Bar**. It also displays “(Modified)” if the file has been changed and not saved yet.

## Ribbon

The **Ribbon** consists **File** and **Home** tabs.

**File** Tab consists of commands to go **Back** to **Home** Tab, create **New** file, **Open** an existing file, **Save** a file, **Save as**, **Import**, **Export** and **Exit**. In addition, the entire **Start Screen** is present under the **File** Tab.

**Home** Tab gives quick access to commands which are needed to complete the task of creating a model, executing it and analyzing solutions. These commands are:

**Project** – enables to enter GENERAL, MATERIALS, RUN OPTIONS, and PROJECT DESCRIPTION.

**Define** – enables to define PROPERTIES, and LOAD CASE/COMBO.

**Section** – enables to create/modify regular and irregular sections and reinforcements.

**Slenderness** – enables to specify various properties related to slenderness.

**Loads** – enables to select load type and assign loads to be used in model.

**Tools** – enables DESIGN TRACE, SUPERIMPOSE, and BATCH PROCESSOR tools.

**Solve** – runs the SOLVER.

**Diagrams** – enables to view PM, MM, 3D-PM, and 3D-MM diagrams.

**Tables** – enables to open **Tables Module** to view tabular input and output.

**Reporter** – enables to open **Reporter Module** to view the Report.

**Display** – enables to toggle on/off model items.

**Viewports** – enables to select from a predefined viewport configuration.

**Settings** – enables to modify various Program settings.

## Left Panel

The properties of active commands under **Home** Tab or the properties of items selected in the **Viewport** are displayed in the **Left Panel** which can then be used to execute the commands or edit the selected items. After execution **Left Panel** displays solutions and also various tools which can be used to explore the graphical results in the **Viewport**.

## Left Panel Toolbar

The **Left Panel Toolbar** contains commands that can be used to edit various items in the **Viewport**.

## Viewport

The **Viewport** covers the majority of the main program window. In the Section scope it is the space where sections can be defined, created and edited. In the Diagrams scope graphical results can be viewed in the viewport. When viewing graphical results of biaxial runs up to 6 viewports can be used at once.

## View Controls

The **View Controls** contains various commands which can be used to adjust the views of **Viewport** both during modeling or viewing the graphical results.

## Drafting Aids

The **Drafting Aids** provides access to various **Viewport** and **Grid** parameters and commands which can facilitate in drafting a model.

## Status Bar

The **Status Bar** displays important information such as the design code being used, run options, loads option, cursor position and current units. It also houses the drafting aid commands.

### 3.3. Tables Window

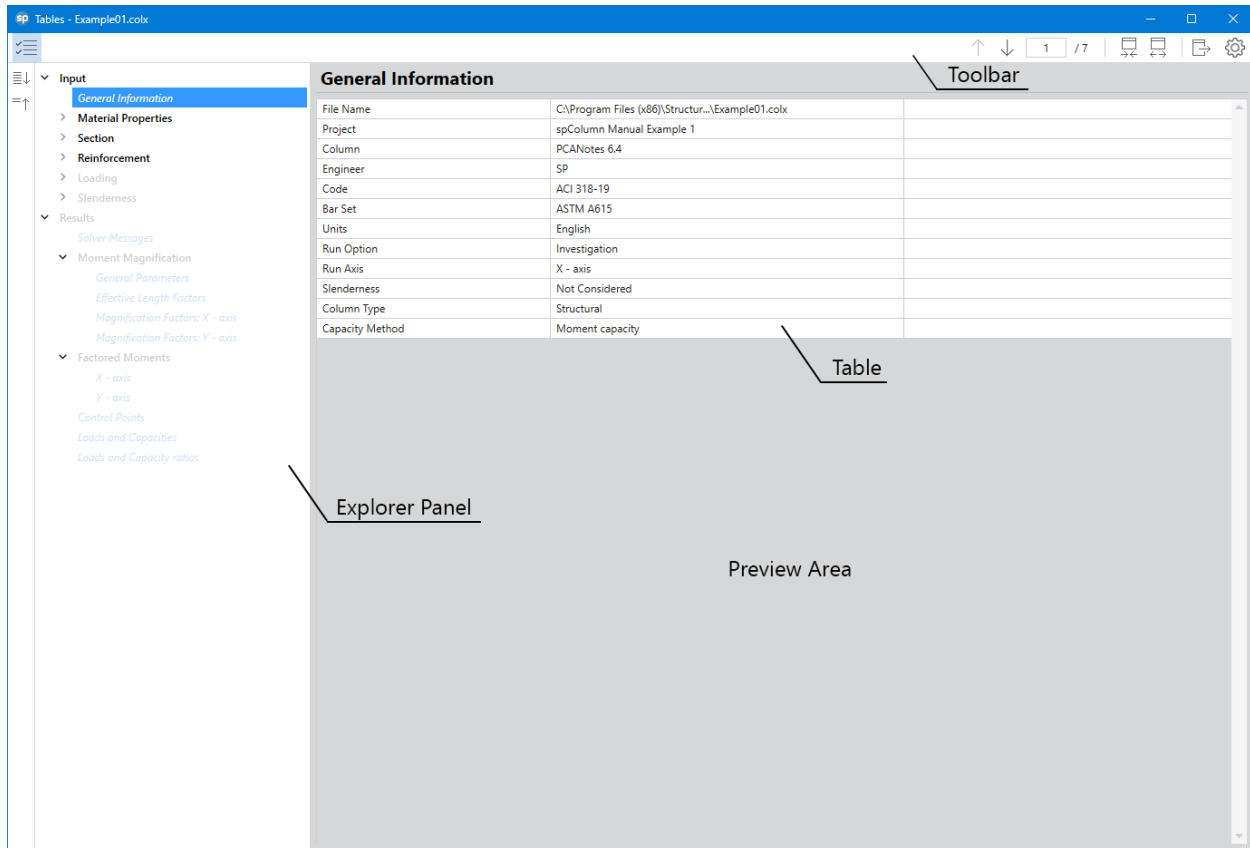

The **Tables Module** interface shown above enables the user to view program inputs and outputs in tables and export them in different formats.

The **Tables Module** is accessed from within the Main Program Window by clicking the **Tables** button from the **Ribbon**. Alternatively, **Tables Module** can also be accessed by pressing the F6 key. If the model has not been executed yet, then the **Tables Module** will only contain a list of input data tables. When a model has been successfully executed, the **Tables Module** will also display the output data tables.

## Toolbar

The **Toolbar** contains commands which can be used to navigate through various Tables

### **Previous table**

Displays the previous table.

### **Next table**

Displays the next table.

### **Table number box**

Displays the table with the table number entered in the box.

### **Auto fit column width to view area**

When toggled on always fits the width of table to the **Preview Area** width.

### **Maintain maximum column width**

Restores all table columns to their default maximum width.

### **Export current table**

Exports the table being viewed in the selected format.

### **Explorer**

Shows or hides the **Explorer Panel**.

## Settings

Contains settings for the **Tables** and **Explorer Panel**.

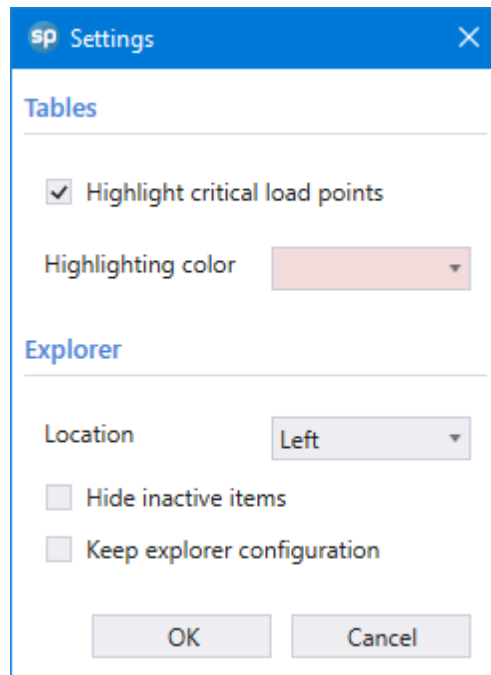

### **Tables settings**

- **HIGHLIGHT CRITICAL ITEMS:** Enables highlighting of critical items in the “Loads and Capacities” table.
- **HIGHLIGHTING COLOR:** Provides color options for highlighting critical items.

### **Explorer settings**

- **LOCATION:** Displays explorer panel on the left or right side of screen depending on selection.
- **HIDE INACTIVE ITEMS:** Hides unused tables from the explorer view.
- **KEEP EXPLORER CONFIGURATION:** Saves the explorer configuration i.e., information about selected tables and opened/closed sections so that it is available next time user opens the tables module.

## Explorer Panel

The **Explorer Panel** consists of all the available items of the inputs and results classified into sections and arranged hierarchically. Any item in the **Explorer Panel** can be clicked on to display the corresponding table in the **Preview Area**.

### **Expand all**

Expands item list.

### **Collapse all**

Collapses item list.

## 3.4. Reporter Window

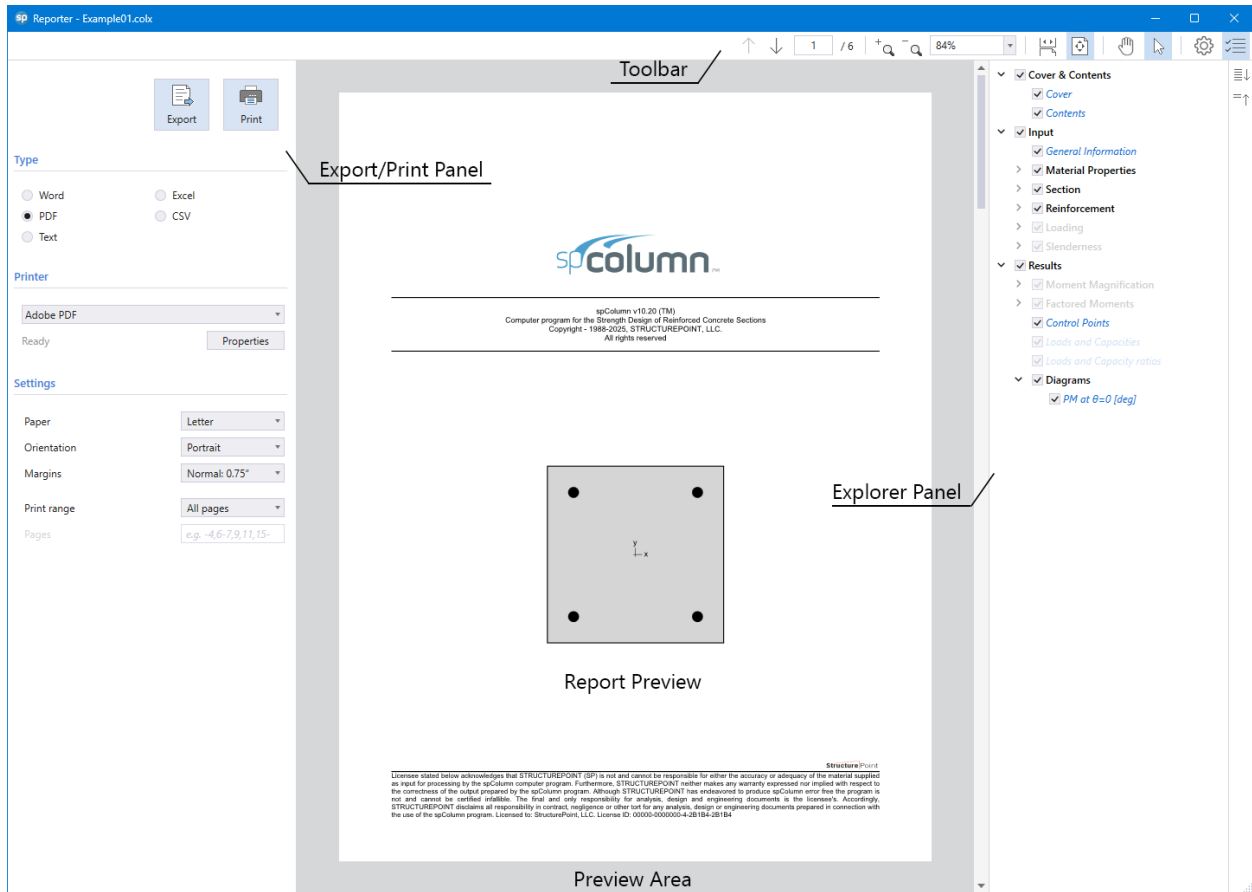

The **Reporter Module** interface shown above enables the user to view, customize, print and export reports in different formats.

The **Reporter Module** is accessed from within the Main Program Window by clicking the **Reporter** button from the **Ribbon**. Alternatively, **Reporter Module** can also be accessed by pressing the F7 key. If the model has not been solved then the **Reporter Module** will only contain a list of input data reports. When a model has been successfully executed, the **Reporter Module** will also display the output data reports. Immediately after opening the **Reporter Module**, you can export and/or print the default report by pressing **Export/Print** button. Various options to customize the report before printing and/or exporting it are also provided. Once the work in **Reporter Module** is complete click the close button in the top right corner to exit **Reporter** window.

## Toolbar

### **Previous page**

Displays the previous page of the report.

### **Next page**

Displays the next page of the report.

### **Page number box**

Displays the page with the page number entered in the box.

### **Zoom in**

Zooms in on the report (Ctrl + Mouse wheel up).

### **Zoom out**

Zooms out on the report (Ctrl + Mouse wheel down).

### **Zoom box**

Zooms on the report preview to the extent typed in the box or selected from the dropdown list.

### **Fit to window width and enable scrolling**

Fits the width of report to the preview space width and enables scrolling.

### **Fit one full page to window**

Fits one full page in the preview space.

### **Pan**

When toggled on and report is bigger than preview window, enables panning the report.

### **Text selection**

When toggled on enables selecting text in the report.

## **Explorer**

Shows or hides the **Explorer Panel**.

## **Settings**

Modifies settings for **Report** and **Explorer Panel**.

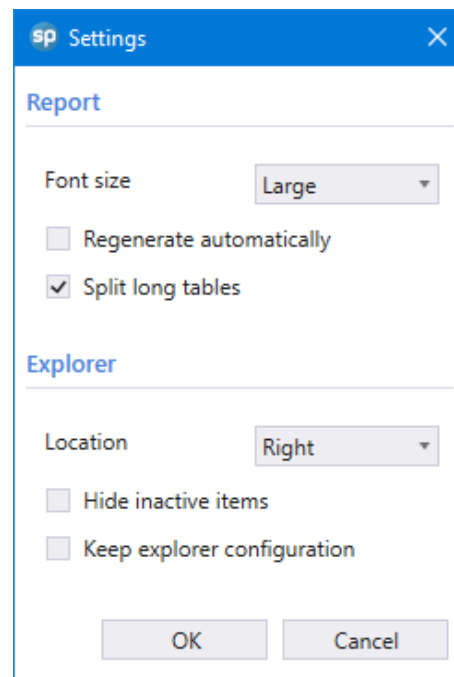

### **Report settings**

- **FONT SIZE:** Provides the options to use small, medium or large font sizes in the report.
- **REGENERATE AUTOMATICALLY:** Enables automatic regeneration of report when content selection is modified by the user.
- **SPLIT LONG TABLES:** Displays table headings in all pages when tables are split along several pages.

### Explorer settings

- LOCATION: Displays **Explorer Panel** on the left or right side of screen depending on selection.
- HIDE INACTIVE ITEMS: Hides unused tables from the explorer view.
- KEEP EXPLORER CONFIGURATION: Saves the explorer configuration i.e. information about selected tables and opened/closed sections so that it is available the next time user opens **Reporter**.

## Export / Print panel

### **Export**

Exports the report in the selected format.

### **Print**

Prints the report in the selected format when the option is available.

### **Type**

Provides 5 format options to print and/or export the reports

- WORD: produces a Microsoft Word file with .docx extension.
- PDF: produces an Adobe Acrobat file with .pdf extension.
- TEXT: produces a Text file with .txt extension.
- EXCEL: produces a Microsoft Excel file with .xlsx extension.
- CSV: produces a Comma Separated file with .csv extension.

### **Printer**

Provides the option to select available printers and change printer properties.

### **Settings**

Provides the options to modify print settings.

- PAPER: Provides the options to select from available paper sizes.
- ORIENTATION: Provides the options to select between landscape or portrait paper orientation.
- MARGINS: Provides the options to use narrow, normal, wide or custom margins to the report
- PRINT RANGE: Provides the options to select the pages to print and/or export.

## Explorer Panel

The **Explorer Panel** consists of all the available report items classified into sections and arranged hierarchically. Each item listed in the **Explorer Panel** is preceded by a checkbox. The user can check/uncheck the checkbox to include or exclude from the report, the items or sections.

### **Expand all**

Expands item list.

### **Collapse all**

Collapses item list

## 3.5. Print/Export Window

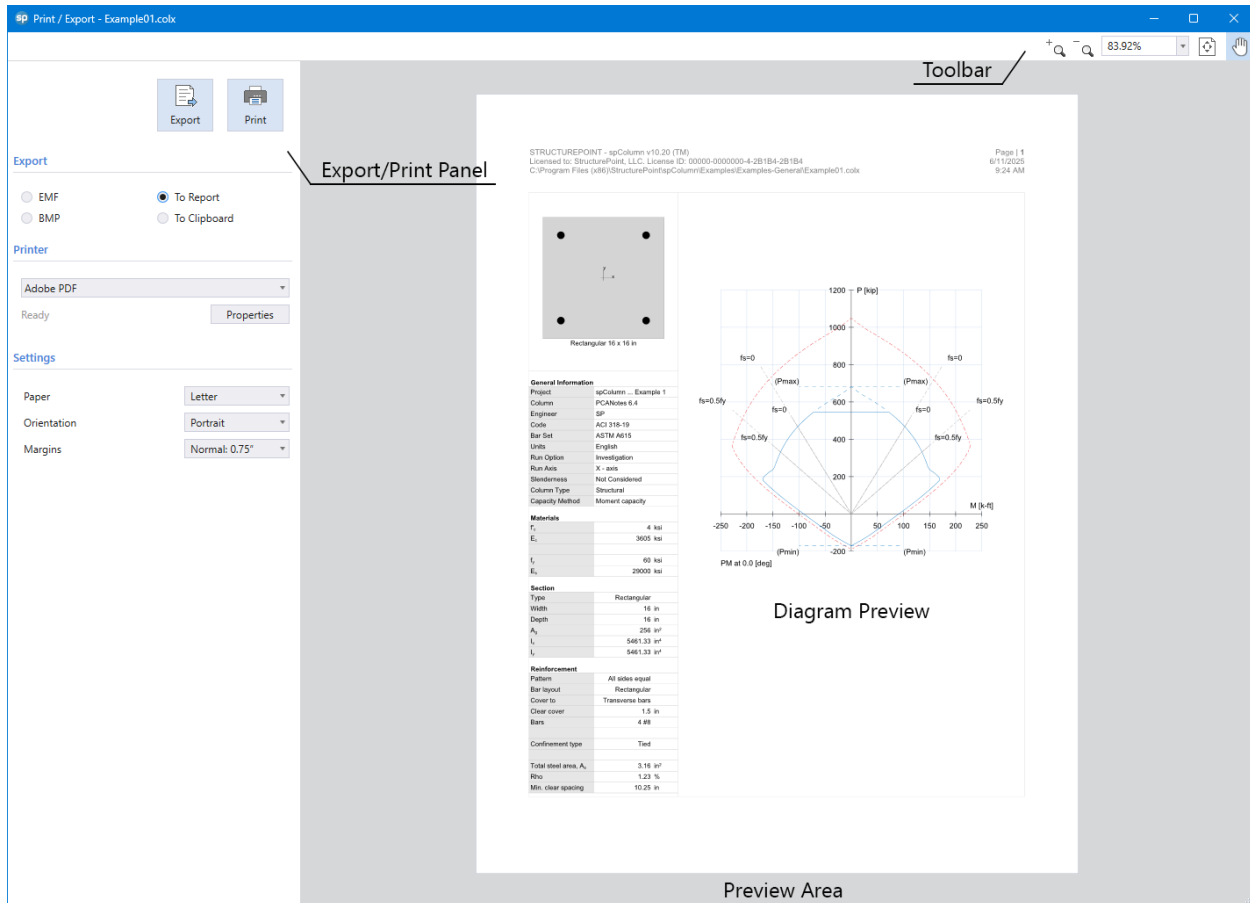

**Print/Export Module** interface shown above enables the user to view, customize, print and export diagrams in different formats.

The **Print/Export Module** is accessed from within the **Main Program Window** by using the **Right Click Menu** in the **Diagrams** scope or from the **Reporter Submenu** in the **Ribbon**.

**Print/Export Module** is only available in the diagrams scope.

Alternatively pressing the “CTRL + P” also opens the **Print/Export Module**. Once the module is open the rest of the program is locked until the **Print/Export Module** is closed.

Immediately after opening the **Print/Export Module**, you can export and/or print the generated diagram by pressing **Export/Print** button. Options to customize the diagram orientation, paper

size and margins are provided. Once the work in **Print/Export Module** is complete click the close button in the top right corner to exit the module.

## Toolbar

### **Zoom in**

Zooms in on the report (Ctrl + Mouse wheel up).

### **Zoom out**

Zooms out on the report (Ctrl + Mouse wheel down).

### **Zoom box**

Zooms on the report preview to the extent typed in the box or selected from the dropdown list.

### **Fit one full page to window**

Fits one full page in the preview space.

### **Pan**

When toggled on and report is bigger than preview window, enables panning the report.

## Export / Print panel

### **Export**

Exports the report in the selected format.

### **Print**

Prints the displayed diagram.

### **Type**

Provides 4 format options to export the reports

- EMF produces a file with .emf extension
- BMP produces a file with .bmp extension
- TO REPORT adds the diagram to the report
- TO CLIPBOARD copies the diagram to clipboard to be pasted elsewhere

### **Printer**

Provides the option to select available printers and change printer properties.

### **Settings**

Provides the options to modify print settings.

- PAPER: Provides the options to select from available paper sizes.
- ORIENTATION: Provides the options to select between landscape or portrait paper orientation.
- MARGINS: Provides the options to use narrow, normal, wide or custom margins to the report.

CHAPTER

4

## MODELING METHODS

---

### 4.1. Model Creation Concepts

---

The key to successful implementation of spColumn in a project is to understand the unique and powerful approach the program takes in modeling, analyzing, designing, and investigating a structural member subjected to combined axial and flexural loads. This chapter provides an overview of assumptions and considerations the design professional must take into account while utilizing spColumn.

As a general rule, the geometry of the analytical model shall correspond to that of the physical member as closely as possible.

The user shall ensure the project criteria aligns correctly with applicable design code and standard provisions on subjects such as load type, load factors, load combinations, material properties and bar sets to name a few.

### 4.1.1. Physical Modeling Terminology

A complete model for a structural member requires detailed knowledge of the target structural member and the adjacent framing elements such as:

1. The design column, pier, wall, or beam
2. Structural element above and below the design member
3. Beams and/or slabs framing at the ends of the member in both orthogonal directions
4. Any other constraints at member ends

**Columns**

- Design Column - X Axis
- Design Column - Y Axis
- Columns Above/Below

**Beams**

- X - Beams
- Y - Beams

**Properties**

- Slenderness Factors

**Design Column**

Design column clear height (lx)  ft

**Sway Criteria**

Nonsway frame  $(\Sigma P_c) / (P_c)$

Sway frame  $(\Sigma P_u) / (P_u)$

2nd order effects along length

**Effective Length Factors**

Compute 'k' factors

Input 'k' factors

k(ns)

k(s)

End conditions:

Copy to Y - Axis

OK Cancel

Refer to [Figure 2.3](#) for additional details of input convention and designations.

### 4.1.2. Structural Member

spColumn allows for designing a new structural member or investigating an existing structural member subject to axial loads with uniaxial or biaxial bending conditions. The components required for successful modeling of structural member is dependent on its slenderness consideration, as follows:

- **Slenderness not considered:** member can be sufficiently modeled with just the section SHAPE geometry, longitudinal BAR arrangement and their material properties.
- **Slenderness considered:** member requires, in addition, the height of design member together with the geometric and material properties of columns and beams/slabs at the top and bottom of the design column. This information is essential for slenderness consideration and is key for the determination of magnified moments and their effects on the structural member.

Slenderness can be considered in spColumn by utilizing the Moment Magnification Method (MMM). When slenderness effects are incorporated elsewhere, the Program can be run by selecting NO for CONSIDER SLENDERNESS run option.

When slenderness effects are considered, the height of the design column is considered in addition to the section dimensions. spColumn allows the effective length factor,  $k$ , either be inputted by the user or computed based on the end conditions. End conditions options enable the user to enter the member properties at the joint or simply assign it to be predefined pin or fixed conditions.

### 4.1.3. Section

The section of the target structural member shall be composed of two essential objects, namely: the SHAPE and the REBAR. The modeling objects available to define the section are:

- **SHAPE** is used to model concrete solids or openings.
- **BAR** is used to model longitudinal reinforcing bars.

In spColumn, the section can be classified as regular or irregular based on the ability of spColumn to perform design based on user specified limits of shape dimensions and commonly used reinforcing bar patterns. Design of regular sections is an iterative process using an advanced algorithm intended to result in an optimal section with adequate strength for the applied loads. Sections that do not qualify as regular are classified as irregular and can be investigated with many variations of shape and bar arrangements as required by the user.

**Regular section** is defined as single solid object with standard shape and regular bar arrangement. Regular sections available in the Program with design options are:

- **Rectangular** is a rectangular solid with rectangular or circular bar layout arranged with all sides equal, equal spacing or sides different.
- **Circular** is a circular solid with rectangular or circular bar layouts arranged with equal spacing.

Design of regular sections is accompanied with a design trace feature allowing the user to follow the progression of design iteration leading to the final proposed design section.

**Irregular section** refers to any representation of single solid or multi-solid section that does not fit the description of a regular section. In other words, it cannot be designed using the standard shapes and bar patterns in the design option. Some of the more common irregular sections are shown as follows:

- Regular solid shape with irregular bar arrangement.

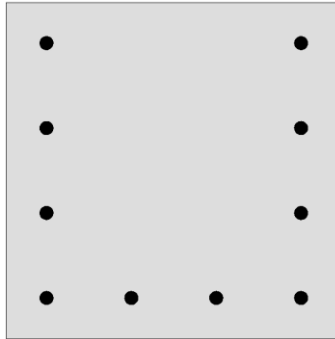

- Irregular solid shape or multiple shapes with regular bar arrangement.

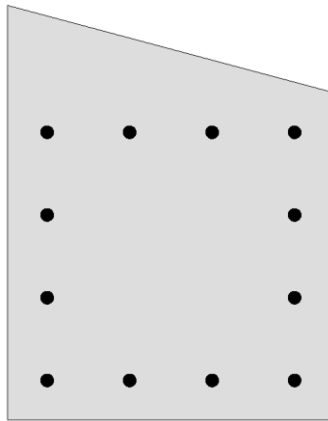

- Irregular solid shape or multiple shapes with irregular bar arrangement.

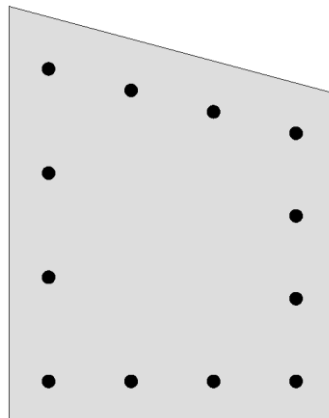

- Solid shape with an interior opening

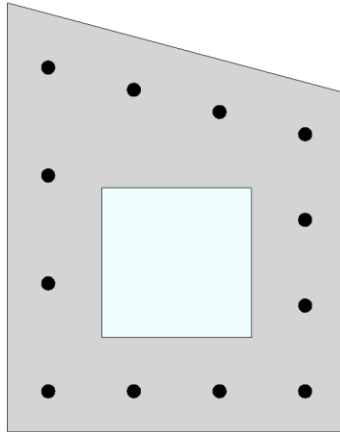

- Solid shape with an exterior opening

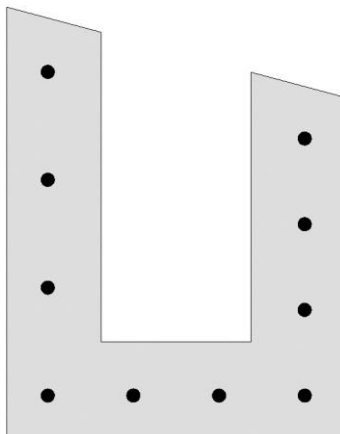

- Section created by advance modeling in spColumn or imported via text or DXF input

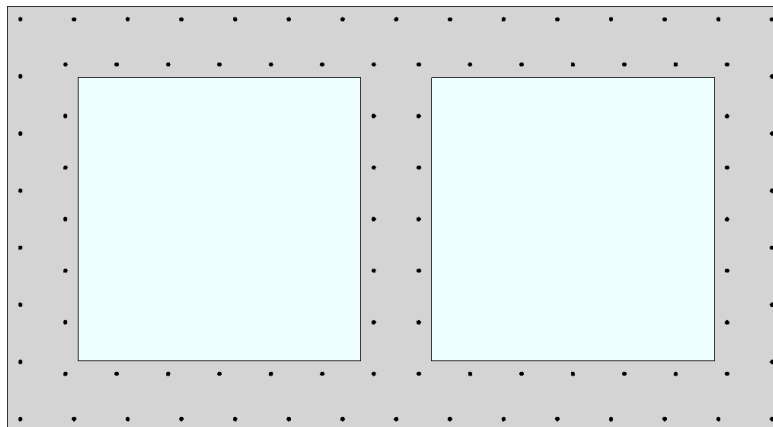

- Sections created using spColumn pre-selected templates

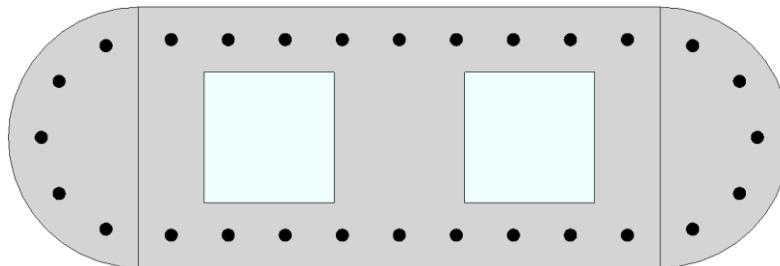
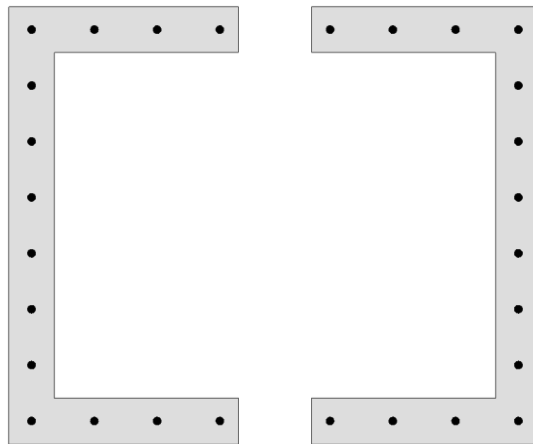
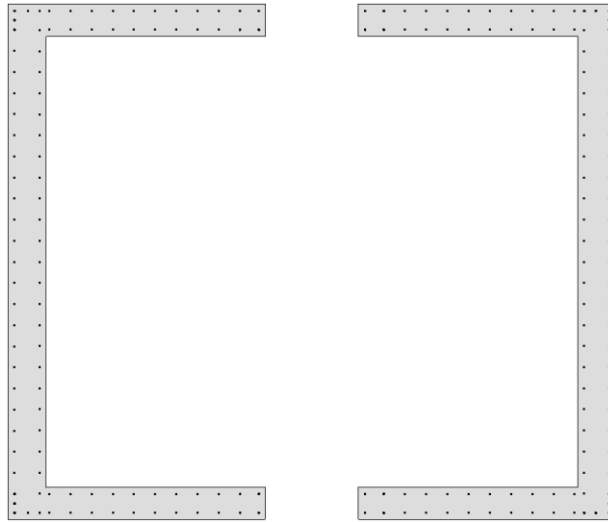

It is the user responsibility to ensure that the program assumptions and relevant code provisions hold true when modeling any irregular sections.

#### 4.1.4. Input Preparation

It is extremely important that all the concepts, assumptions and definitions are understood in order for the analytical model to achieve compliance with supporting provisions permitted by the applicable codes and standards used. It is also essential for the proper interpretation of design and analysis results.

In each model the run option of design or investigation depending is selected by the user based on project needs. The STRENGTH properties of concrete and reinforcing steel are input by the user for modeling the structural member and other members at end conditions. Other material properties are normally calculated per the code standard unless the user elects non-standard manual input.

The BAR SET can be selected as pre-defined sets per American and Canadian standards or the user can create user-defined set for other international design standards or to mimic the area of a bundled bar.

Model input requires a choice of run axis. The BIAXIAL bending consideration constitutes the most comprehensive state that enables the creation of the 3D failure surface and therefore, may be utilized by the user as a default condition in any model. The Uniaxial run option concerns either with ABOUT X-AXIS or ABOUT Y-AXIS runs. If a section does not undergo biaxial bending, the utilization of uniaxial option results in simpler output and fewer input requirements.

The axial load only condition may occur if the bending is negligible. A common case of this is interior column where unbalanced bending moments are negligible. Edge columns may be modeled for axial load with uniaxial bending. Corner columns often require to be modeled for axial load with biaxial bending.

### 4.1.5. Modeling Considerations

The following set of conditions need to be met for spColumn to proceed with a model solution, otherwise, the program shall provide an error message and the user shall resolve them:

- Each opening shape shall be entirely within a solid shape.
- Solid shapes should not overlap.
- Opening shapes should not overlap.

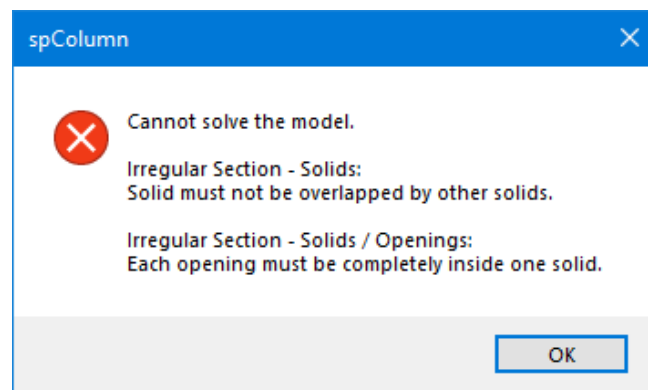

For the following second set of conditions, if any is not met spColumn shall provide a warning message and require user's permission to proceed:

- The rebar shall need to be placed inside the section.
- The rebar shall not overlap with another rebar.
- Reinforcement ratio shall need to be in between the accepted range for columns 1% - 8%. Where reinforcement ration falls below 1% the program will provide the user with a choice between Architectural and Structural column. An article outlines the background of this choice [Columns with Low Reinforcement – Architectural Columns](#)

Models not meeting these conditions may be for academic and research purposes to investigate transformed cracked sections and other theoretical circumstances. StructurePoint does not support the utilization of spColumn and its results for these models, due to numerical instabilities during analysis run.

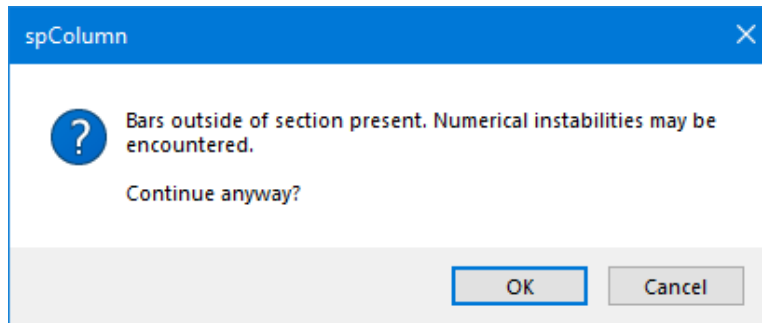

## 4.2. Model Editing Concepts

---

A model file will normally contain base sections for regular rectangular and circular sections to represent a model starting point. Any regular section or template can also be sent to irregular for custom editing and modifications of non-regular (irregular) shapes and reinforcing arrangements. The model file will retain any regular and irregular cross sections created in the spColumn model. These various sections typically will coexist and are hosted in the same model file and may be solved individually using the project criteria and definitions created within one model file. Once a model is solved however for any of these section, the resulting tabular and graphical output is reset for that section that is active. To manage model sections effectively, it is important to note the following

- The user has the added flexibility of retaining three sections in a model file.
- Only one section type can be active at a time and is then available for review and editing.
- The user must review the active section thoroughly before solving to ensure the desired configuration
- Switching between section types allows the user to evaluate options for cross sectional shape and reinforcing arrangement in regular sections before sending to irregular for additional custom editing options.
- New regular cross sections sent to irregular for custom editing will cause previously created irregular sections to be discarded
- Once the solver is engaged, the active cross section (regular or irregular) will be solved and the output files will reflect the results and diagrams for the active cross section.

During the course of creating a model, it may be necessary to edit the model. This can be done by going back to **Section**. The options available per section type are:

- Regular:** In regular sections the size, bar arrangement, reinforcement properties and cover type can be edited automatically by changing any of the parameters in the **Left Panel**. The properties section on the bottom of the **Left Panel** interactively reflects the changes made by the user.
- Template (will be available in spColumn v11.00):** In template sections the geometric dimensions, reinforcement and other template specific options can be edited automatically by changing any of the parameters in the **Left Panel**. The bars arrangement and template shape can also be changed.
- Irregular:** In irregular sections any object that is present on the active **Viewport** can be selected and its properties can be modified in **Left Panel**. When multiple different object types are selected, all applicable parameters will be populated at the **Left Panel**. The objects can also be edited by the tools available within the **Left Panel Toolbar**. These editing tools can also be invoked by right-clicking the mouse button in the active viewport to facilitate additional options for the user to edit.

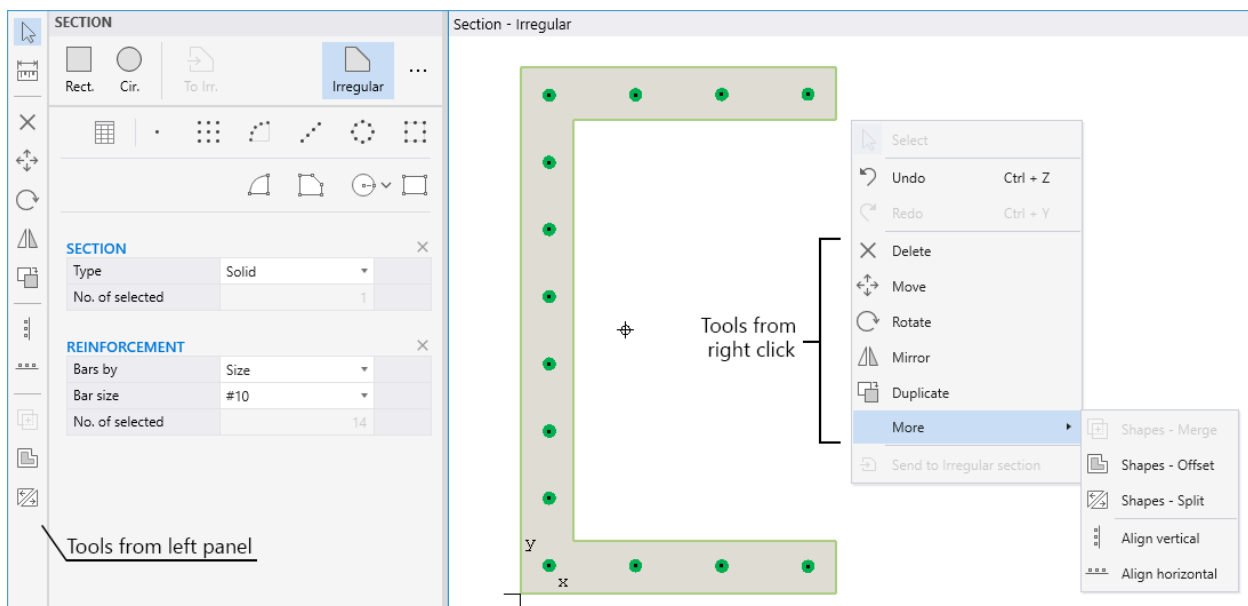

A convenient method for modeling and editing complex sections is to draw base shapes that overlap to create the desired final shape. The MERGE tool can be used to combine the component shapes and avoid any geometric errors.

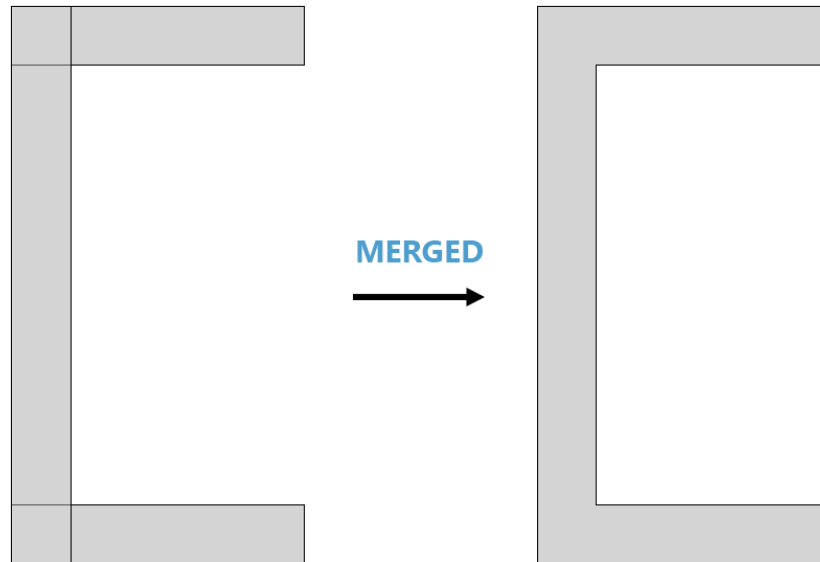

Starting with Version 10.00 of spColumn, a model can be made with multiple solid shapes each capable of containing multiple openings. Models with multi solids can be solved by spColumn to design and determine the strength of member cross sections encountered in buildings, bridges, and numerous other structures. In multi solid models the user has a choice to merge the shapes into one final combined model or keep the shapes separated without merging them. Shapes can be kept separate to facilitate modification to the geometry of the shape and the reinforcing bar arrangement.

The spColumn solver requires merging of multi solid shapes only when they are overlapped. The MERGE tool can be used to combine overlapping solids and prepare the model for solving. It is always feasible to use the SPLIT tool to separate a single solid back to original solid components or new solid components to support further model editing and development. The following figure describes possible scenarios discussed above. Additionally, a video providing a description of this feature showing conceptual models for building and bridge applications is available [here](#). It illustrates editing techniques and examples for merging multiple solids or keeping them separated when they do not overlap.

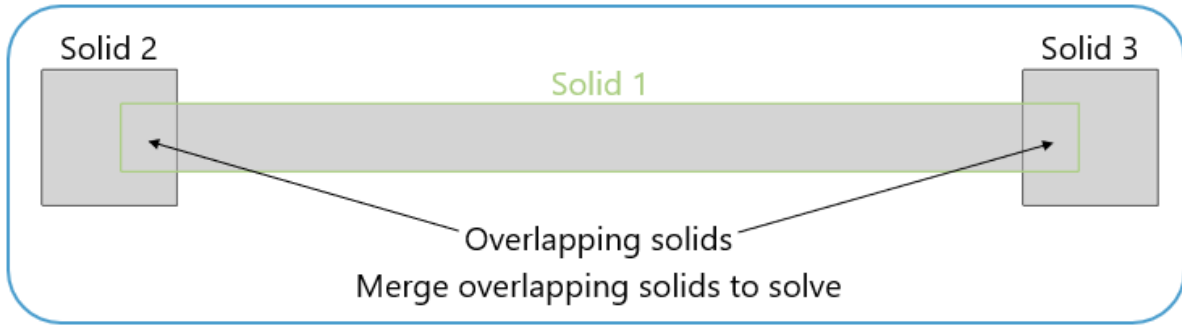

Using the MERGE tool

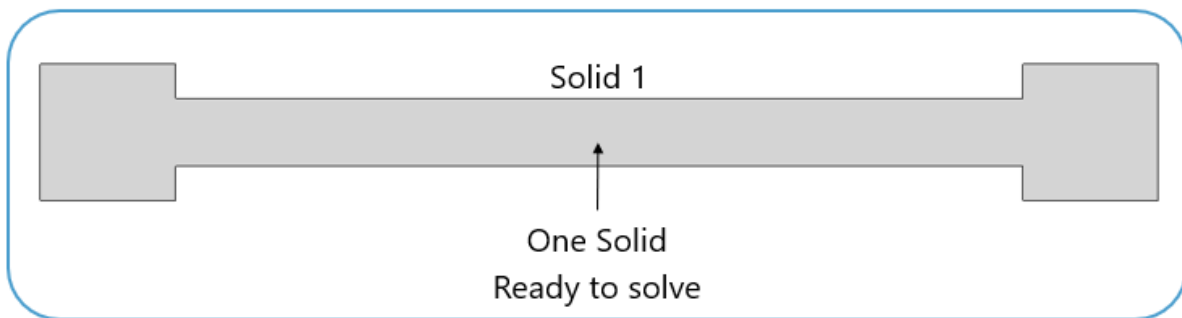

Using the SPLIT tool

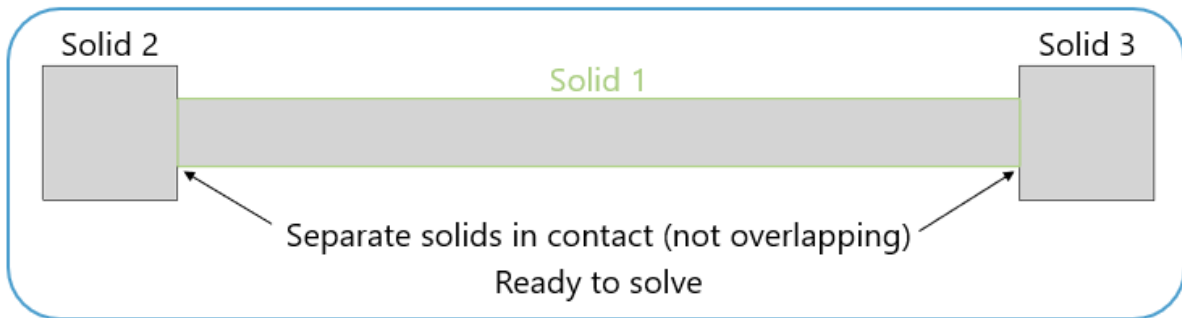

CHAPTER

5

## MODEL DEVELOPMENT

---

### 5.1. Model Creation

---

In spColumn, models can be started by utilizing one of four methods under Projects within **Start Screen**. These are namely; **Open Project**, **New Project**, **Templates** and **Examples**. Each of these methods can be used to create a new model from scratch, edit a model developed previously for an earlier project, start with pre-defined template, or use an existing example file from the provided library. Each of the methods are described in detail in this chapter.

The screenshot shows the spColumn software interface. The window title is "spColumn - Untitled". The interface is divided into three main sections: "Projects", "Recent", and "Resources".

- Projects:** Contains three items: "New project", "Open project", and "Examples".
- Recent:** Lists three recent projects with their file paths:
  - Rectangular Bridge Pier Tied Uniaxial.colx**  
C:\Program Files (x86)\StructurePoint\spColumn\Examples\Examples-Regular
  - Square Bridge Pier Rounded.colx**  
C:\Program Files (x86)\StructurePoint\spColumn\Examples\Examples-Irregular
  - Clover Shaped Column.colx**  
C:\Program Files (x86)\StructurePoint\spColumn\Examples\Examples-Irregular
- Resources:** Contains several links: "Manual...", "Design Examples...", "Tutorial Videos..." (with a play button icon), "spColumn Info...", "Submit a Question...", "Check for Updates...", "Release Notes...", and "About spColumn".

At the bottom of the interface, there is a "Clear all history" button and a copyright notice: "spColumn v10.20 (TM) Copyright © 1988-2025, STRUCTUREPOINT, LLC."

## 5.2. Opening Existing Models

---

In the **Start Screen** under **Projects** select the OPEN PROJECT option and browse to the folder that contains an existing spColumn input file. The input files created in spColumn Version 7.00 and prior (.col) and in spColumn Version 10.00 can be opened. There is no backward compatibility in spColumn which means the input files for newer versions of the Program cannot be opened by a previous version.

## 5.3. Creating New Models

In the **Start Screen** under **Projects** select the NEW PROJECT option. The model development process may require general input regarding a specific project. Project Information, Materials and Run Options are entered through the **Project** command button.

### 5.3.1. Project Information

The project information regarding DESIGN CODE, UNIT SYSTEM, BAR SET, CONFINEMENT, SECTION CAPACITY, CONCRETE STRENGTH, REINFORCING STEEL STRENGTH, RUN OPTIONS, RUN AXIS, SLENDERNESS, PROJECT, COLUMN, and ENGINEER can be entered into the model through the **PROJECT Left Panel**. The Program supports American (ACI 318) and Canadian (CSA A23.3) Design Codes, and English and Metric unit systems.

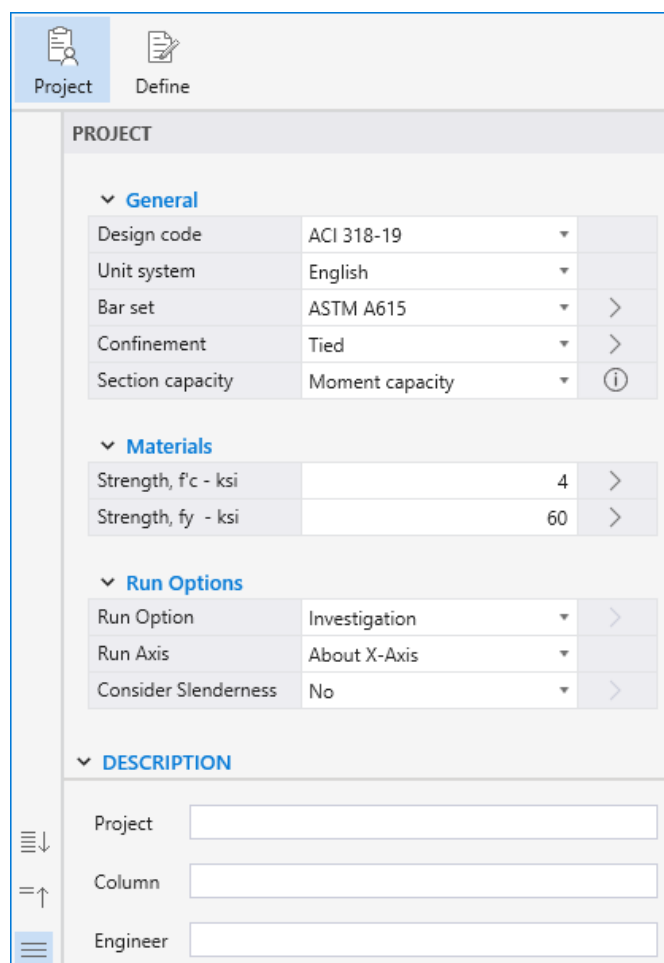

PROJECT	
<b>General</b>	
Design code	ACI 318-19
Unit system	English
Bar set	ASTM A615
Confinement	Tied
Section capacity	Moment capacity
<b>Materials</b>	
Strength, f'c - ksi	4
Strength, fy - ksi	60
<b>Run Options</b>	
Run Option	Investigation
Run Axis	About X-Axis
Consider Slenderness	No
<b>DESCRIPTION</b>	
Project	<input type="text"/>
Column	<input type="text"/>
Engineer	<input type="text"/>

### 5.3.2. Generating Definitions

The DEFINE dialog box contains two categories: PROPERTIES and LOAD CASES/COMBINATIONS.

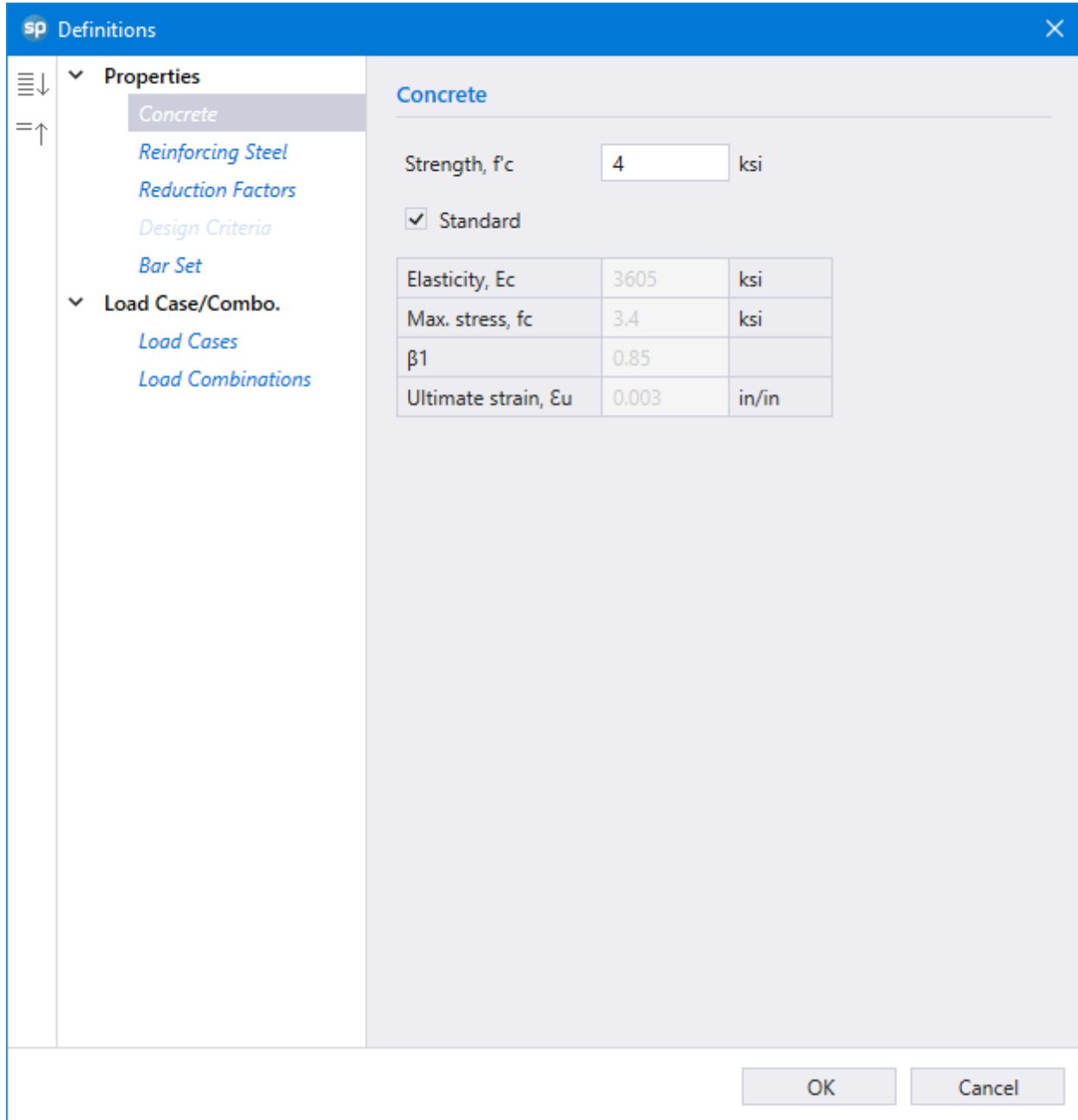

### 5.3.2.1. Properties

The PROPERTIES that can be defined are: CONCRETE, REINFORCING STEEL, REDUCTION FACTORS, DESIGN CRITERIA and BAR SET.

#### **Concrete**

The concrete compressive STRENGTH,  $f_c'$ , is entered by the user. Other concrete properties including:

- Modulus of ELASTICITY,  $E_c$
- MAX STRESS,  $f_c$ , the constant stress intensity at the maximum usable strain used to calculate the force on concrete.
- $\beta_1$ , the factor used to determine the depth of the stress block.
- ULTIMATE STRAIN,  $\epsilon_u$ , maximum usable strain at the extreme concrete compression fiber.

are automatically computed and displayed when STANDARD option is selected. The user can manually modify any of the values by deselecting the option. The user is cautioned when using non standard user defined material properties to observe the corresponding required code provisions.

#### **Reinforcing Steel**

The reinforcing steel yield STRENGTH,  $f_y$ , is entered by the user. when STANDARD option is selected, other reinforcing steel properties:

- Steel ELASTICITY,  $E_s$ , and
- Compression-controlled strain limit,  $\epsilon_{ty}$

are automatically computed (based on the code selected) and displayed. if STANDARD option is deselected, the user needs to input  $E_s$  and  $\epsilon_{ty}$  manually. The  $\epsilon_{ty}$  input can be calculated as  $f_y / E_s$  and shall be smaller than 0.005 for ACI 318-14 and prior, or 0.01 for ACI 318-19.

### **Reduction Factors**

The CAPACITY REDUCTION FACTORS,  $\phi$ , are based on the CONFINEMENT type: TIED, SPIRAL or OTHER. When TIED or SPIRAL are selected, the program will automatically adjust the factors based on the design code and selection. However, if the confinement type selected is OTHER, the user has to enter and modify the values manually.

- The CAPACITY REDUCTION FACTORS available for ACI code:
  - $\phi$  (a), the reduction factor for allowable compression,
  - $\phi$  (b), the reduction factor for tension-controlled failure,
  - $\phi$  (c), the reduction factor for compression-controlled failure.
- The MATERIAL RESISTANCE FACTORS available for CSA code:
  - $\phi$  (a) is the reduction factor for allowable compression,
  - $\phi$  (s) is the material resistance factor for steel,
  - $\phi$  (c) is the material resistance factor for concrete.

Note that two important items require attention when using CSA A23.3-19/14:

1. The reduction factor AXIAL COMPRESSION, (a), is variable and its value is shown as VAR.
2. The minimum section dimension, h, must also be specified for Irregular sections.

### **Design Criteria**

The DESIGN CRITERIA is available with the DESIGN RUN OPTION only. The user can specify the criteria based on COLUMN TYPE, REINFORCEMENT RATIO, REINFORCEMENT BARS, and CAPACITY RATIO.

- The MINIMUM and MAXIMUM reinforcement ratios change depending on the selection of column type: STRUCTURAL or ARCHITECTURAL. USER-DEFINED option allows the user to modify the limiting reinforcement ratios, MINIMUM and MAXIMUM.
- The bars layout criteria are based on MINIMUM NUMBER OF BARS or on MINIMUM AREA OF STEEL, and the MINIMUM CLEAR SPACING BETWEEN BARS.
- The ALLOWABLE CAPACITY RATIO that indicates the level of safety for the design is also required. Ratio that is less than 1.0 indicates the section is safe.

SP Definitions
✕

**Properties**

- Concrete
- Reinforcing Steel
- Reduction Factors
- Design Criteria
- Bar Set

**Load Case/Combo.**

- Load Cases
- Load Combinations

### Column Type

Structural
  User-defined  
 Architectural

### Reinforcement Ratio

Minimum	1	%
Maximum	8	%

### Reinforcement Bars

Bar selection Min. number of bars

Min. clear spacing between bars 1.5 in

### Capacity Ratio

Allowable capacity (Ratio) 1

Ratio < 1 is safe

OK
Cancel

## **Bar Set**

The BAR SET can be selected from pre-defined standard sets or can be USER-DEFINED. For a new USER-DEFINED set entry, the SIZE, DIAMETER, AREA and WEIGHT of the bar are required. USER-DEFINED set can also be imported or exported.

### 5.3.2.2. Load Case/Combo

The LOAD CASE/COMBO that can be defined are: LOAD CASES and LOAD COMBINATIONS.

#### **Load Cases**

The LOAD CASES definition consists of the CASE, TYPE, and SUSTAINED LOAD (%). SUSTAINED LOAD (%) of load cases can only be edited when slenderness is considered in the model. Load type DEAD is sustained at 100% by default.

#### **Load Combinations**

The LOAD COMBINATIONS definition consists of the load combination name, COMBO, LOAD CASE TYPE, and LOAD FACTORS. Default load combinations can also be generated automatically based on the design code in the model.

spColumn allows the user to specify up to 50 load combinations. The service load cases (DEAD, LIVE, WIND, EARTHQUAKE (EQ), and SNOW) are combined based on these combinations. A minimum of one combination must be input.

### 5.3.3. Creating Section

#### Section

A new section can be created from the **Section** scope in the **Ribbon**.

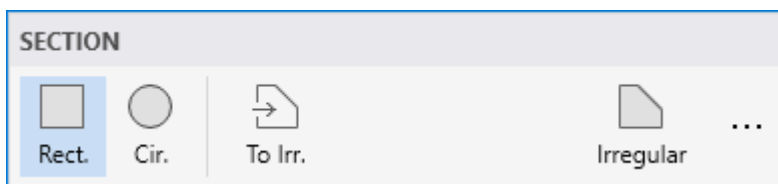

In DESIGN MODE, you can create a REGULAR section using the options available in the **Left Panel**. You can simply select the SECTION, RECTANGULAR or CIRCULAR, and enter the SIZE, BAR ARRANGEMENT, REINFORCEMENT and COVER TYPE data in the **Left Panel**. The section will automatically change according to the data entered.

In INVESTIGATION MODE, in addition to REGULAR sections, TEMPLATES and IRREGULAR sections can also be created.

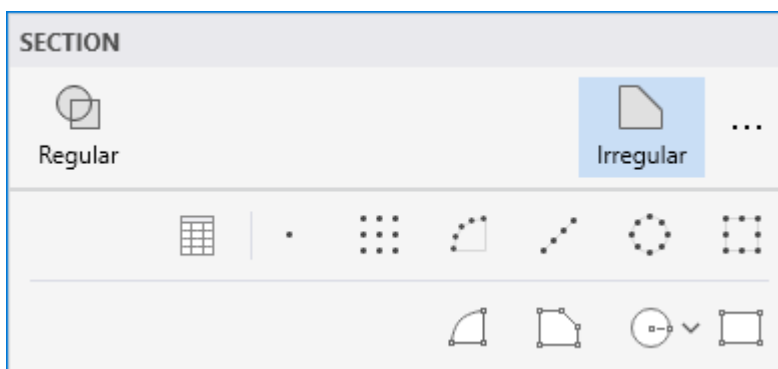

IRREGULAR section option enables the user to investigate irregularly shaped reinforced concrete sections subject to a combination of loadings. Irregular sections may contain multi-solids and multi-openings with reinforcement bars.

The SECTIONS geometry may then be defined by utilizing the drawing tools and options available at the left panel. Drawing tools are available for drawing SHAPES and BARS.

A SHAPE can be created as a solid or an opening by selecting the suitable drawing tool and entering its coordinates and dimensions. This can be done either by clicking on the workspace or by using the dynamic input feature. Other shape properties can be assigned in the left panel. The Shape-drawing tools available in the program are:

- **Rectangle** - Creates rectangular shape.
- **Circle** - Creates circular shape in one of the three methods: by radius, by diameter, by tangent points.
- **Arc** - Creates arc shape.
- **Polygon** - Creates polygon shape by specifying its vertices.

BARS can be laid out in different patterns by quantity (number) or spacing guided by the selected concrete cover. Multiple bars are created based on the active bar layout and specified bar number and spacing. The bar properties can be selected in the left panel. Bars can be created directly on the workspace by clicking on the required points by using the dynamic input feature to enter the precise. The bar-drawing tools available in the program are:

- **Single** – Add single reinforcement bar
- **Linear** – Add bars in linear pattern
- **Rectangular** – Add bars in rectangular pattern
- **Circular** – Add bars in circular pattern
- **Grid** - Add bars in grid pattern
- **Arc** - Add bars in arc pattern

Irregular section and its components can also be edited and modified using Editing Tools available. These tools are added to help ease and speed up drawing complex shapes. The Editing tools available in the program are: MEASURE, DELETE, MOVE, ROTATE, MIRROR, DUPLICATE, ALIGN VERTICAL, ALIGN HORIZONTAL, MERGE, OFFSET AND SPLIT.

### 5.3.4. Generating Loads

The LOAD dialog box contains two categories: LOADS and MODES (NO LOADS).

#### 5.3.4.1. Loads

##### **Factored Loads**

When designing or investigating a non-slender column, factored loads consisting of applied axial loads and moments about the active axis may be input. This type of loads is not available for slender columns.

The screenshot shows the 'Loads' dialog box with the 'Factored Loads' tab selected. The table below represents the data entered in the dialog:

No.	Pu	M(ux)	M(uy)
	kips	kip-ft	kip-ft
1	100	20	20
2	100	-20	-20

The diagram on the left, titled 'Positive Moment Loads', illustrates a vertical column with a coordinate system (x, y, z). The x-axis is horizontal, the y-axis is vertical, and the z-axis is along the length of the column. Moment vectors  $M_{ux}$  and  $M_{uy}$  are shown acting on the column.

## Service Loads

When designing or investigating a non-slender or slender column, service level loads consisting of dead, live, lateral (wind and earthquake), and snow axial loads and moments at both column ends about the active axis may be input. These loads are then factored and combined based on the load combinations.

The screenshot shows the 'Loads' application window with the 'Service Loads' dialog box open. The dialog is divided into several sections:

- Left Panel:** A tree view showing 'Loads' expanded to 'Service Loads'. Below it are 'Modes (No Loads)', 'Axial Load Points', and 'Control Points'. A diagram titled 'Positive Moment Loads' shows a column with coordinate axes (x, y, z) and moment vectors (Mx, My) at the top and bottom ends.
- Service Loads Table:** A table with columns: Load Case, Name, P (kips), Mx (Top) (kip-ft), Mx (Bot) (kip-ft), My (Top) (kip-ft), and My (Bot) (kip-ft).
 

Load Case	Name	P (kips)	Mx (Top) (kip-ft)	Mx (Bot) (kip-ft)	My (Top) (kip-ft)	My (Bot) (kip-ft)
>	Dead	150	0	0	0	0
	Live	100	20	20	20	20
	Wind	0	0	0	0	0
	EQ	0	0	0	0	0
	Snow	0	0	0	0	0
- Buttons:** '+ New', 'X Delete', 'Clear', 'Remove Duplicates', and 'Import / Export'.
- Case List:** A table with columns: No. and [P, Mx (Top), Mx (Bot), My (Top), My (Bot)] for each case.
 

No.	[P, Mx (Top), Mx (Bot), My (Top), My (Bot)] for each case
> 1	D [150, 0, 0, 0, 0]; L [100, 20, 20, 20, 20]; W [0, 0, 0, 0, 0]; E [0, 0, 0, 0, 0]; S [0, 0, 0, 0, 0]
- Bottom Right:** 'OK' and 'Cancel' buttons.

### 5.3.4.2. Modes (No Loads)

#### **Axial Load Points**

When investigating a non-slender column under uniaxial load, grouped factored applied axial loads may be input. The corresponding moment capacity under each axial load is computed and output. This command is not available for biaxial runs, slender columns nor under the DESIGN option.

#### **Control Points**

A non-slender column may be investigated without inputting any loads. The capacity of the section is computed along with other section capacity parameters. This command is not available for slender columns or under the DESIGN option.

In the output file, key points (e.g., balanced point and pure bending) on the interaction diagram are listed. For each point, the axial load and bending moment capacities, along with the corresponding neutral axis depth, distance from extreme compression fiber to centroid of extreme layer of longitudinal tension steel, net tensile strain in extreme layer of longitudinal tension steel at nominal strength, and strength reduction factor (ACI only) are listed. For a biaxial run, these points are listed for bending about positive and negative X and Y axes.

For ACI code, the program flags the unusual increase in axial load capacity in transition zone between the balanced point and the tension control point.

For uniaxial runs, the bar splice requirements for columns<sup>1</sup> are indicated on the interaction diagram as discussed in the method of solution chapter.

---

<sup>1</sup> ACI 318-14, Fig. R10.7.5.2; ACI 318-11, Fig. R12.17; ACI 318-08, Fig. R12.17; ACI 318-05, Fig. R12.17; ACI 318-02, Fig. R12.17; CSA A23.3-14, 12.17.3; CSA A23.3-04, 12.17.3; CSA A23.3-94, 12.17.3

### 5.3.5. Slenderness

The **Slenderness** dialog and commands are active only when slenderness is considered in the model. The **Slenderness** dialog contains three categories: COLUMNS, BEAMS and PROPERTIES.

#### Columns

##### 5.3.5.1. Design Column (X-Axis and Y-Axis)

Properties of the design column related to its SWAY CRITERIA and EFFECTIVE LENGTH in both X-AXIS and Y-AXIS can be assigned in this section. The user should input the DESIGN COLUMN CLEAR HEIGHT,  $l_x$ , and specify whether the model is laterally braced against sidesway or not.

For sway columns, the following two ratios are required:

- The sum of the critical load of all story columns to the critical load of the column under consideration,  $(\Sigma P_c)/P_c$ .
- The sum of the factored axial load of all story columns to the factored axial load of the column under consideration,  $(\Sigma P_u)/P_u$ .

The 2ND ORDER EFFECTS ALONG LENGTH can also be considered. This option is available for ACI 318-19, ACI 318-14, ACI 318-11, and ACI 318-08 codes only.

The EFFECTIVE LENGTH FACTORS can be computed by the program based on the selected END CONDITIONS, or by manually inputting the values for nonsway and sway conditions,  $k(ns)$  and  $k(s)$ , respectively.

sp Slenderness
✕

**Columns**

- Design Column - X Axis
- Design Column - Y Axis
- Columns Above/Below

**Beams**

- X - Beams
- Y - Beams

**Properties**

- Slenderness Factors

### Design Column

Design column clear height (lx)  ft

---

### Sway Criteria

Nonsway frame       $(\sum Pc) / (Pc)$      

Sway frame       $(\sum Pu) / (Pu)$      

2nd order effects along length

---

### Effective Length Factors

Compute 'k' factors      End conditions:

Input 'k' factors

k(ns)

k(s)

### 5.3.5.2. Columns Above/Below

This command is available for slender columns only for which the COMPUTE K FACTORS option is selected in the DESIGN COLUMN-X AXIS or DESIGN COLUMN-Y AXIS Menus.

Specify whether or not a column above or below the design column exists, by selecting other than the “NONE” option. If the columns above or below exist, then their section shape and properties are required. The columns can have similar properties to the design column. Further, if the column above and the column below are the same, the properties of one can be copied to the other.

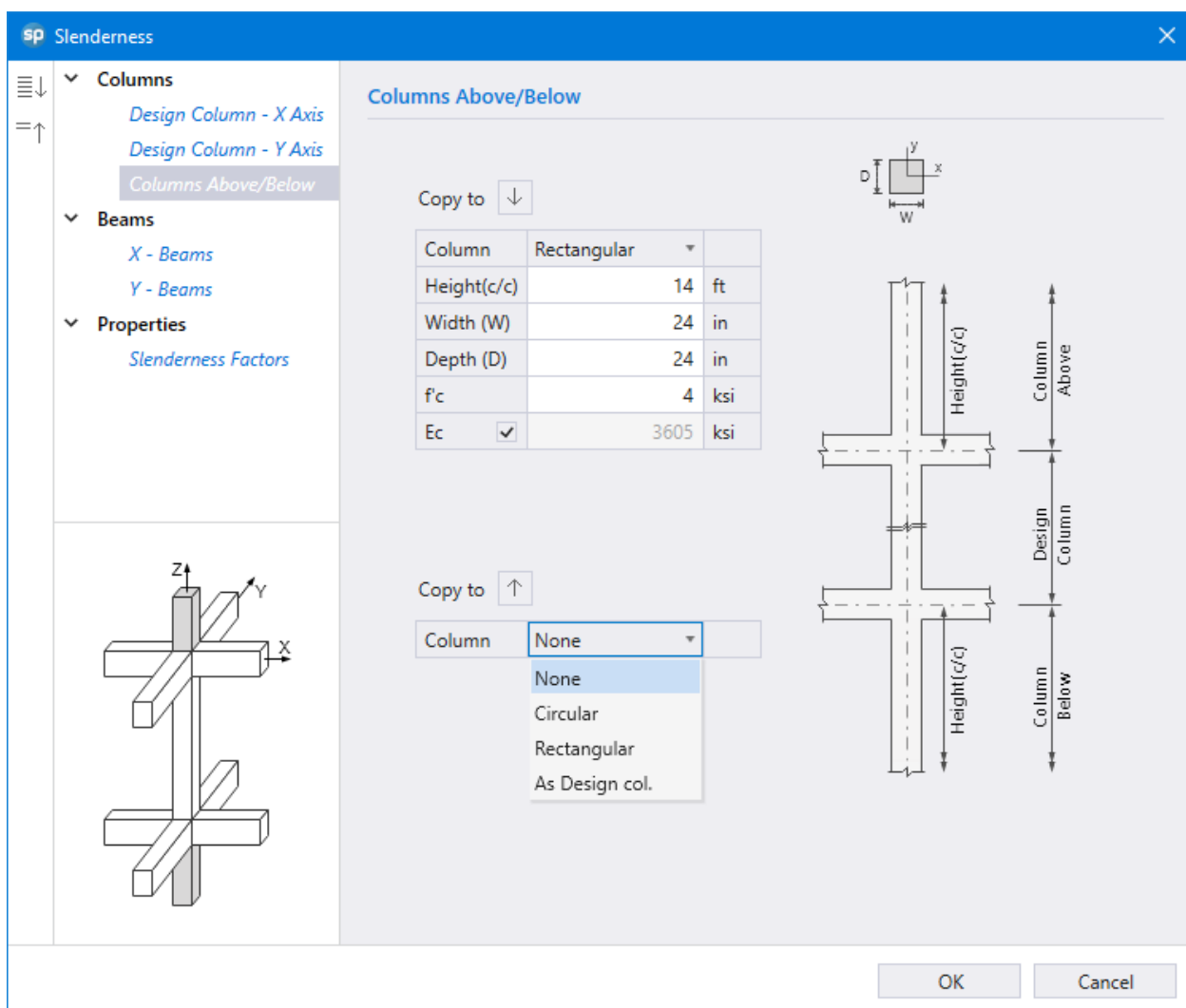

## Beams

### 5.3.5.3. X – Beams and Y – Beams

Beams defined using these commands span perpendicular to the x-axis and y-axis, respectively. These two commands are available for slender columns only for which the COMPUTE K FACTORS option is selected in the DESIGN COLUMN-X AXIS or DESIGN COLUMN-Y AXIS Menus and RUN AXIS is either BIAXIAL or UNIAXIAL ABOUT X-AXIS or UNIAXIAL ABOUT Y-AXIS.

For any selected beam, specify whether or not it exists by selecting other than the “NONE” option. Beams can be RIGID or RECTANGULAR. For RECTANGULAR beams, enter the center-to-center span length, the geometric section dimensions and concrete strength. Material and section properties can be automatically computed by the program or modified manually by the user. Further, the properties of any of the four beams can be copied to one or multiple adjacent beams on the same axis. All the properties of X-Beams and Y-Beams can be copied as well.

Slenderness
✕

**Columns**

- Design Column - X Axis
- Design Column - Y Axis
- Columns Above/Below

**Beams**

- X - Beams
- Y - Beams

**Properties**

- Slenderness Factors

### X - Beams (Perpendicular to X)

Copy to ↓ → all

Beam	Rectangular	
Span(c/c)	18	ft
Width (W)	20	in
Depth (D)	24	in
Inertia <input checked="" type="checkbox"/>	23040	in <sup>4</sup>
f'c	4	ksi
Ec <input checked="" type="checkbox"/>	3605	ksi

Copy to ↓ ← all

Beam

- None
- None
- Rectangular
- Rigid

Copy to ↑ → all

Beam

- Rigid

Copy to ↑ ← all

Beam

- Rigid

OK
Cancel

### 5.3.5.4. Slenderness Factor

The STIFFNESS REDUCTION FACTOR and CRACKED SECTION COEFFICIENTS can be defined in this section. The factors can be default by the design code or manually defined by the user.

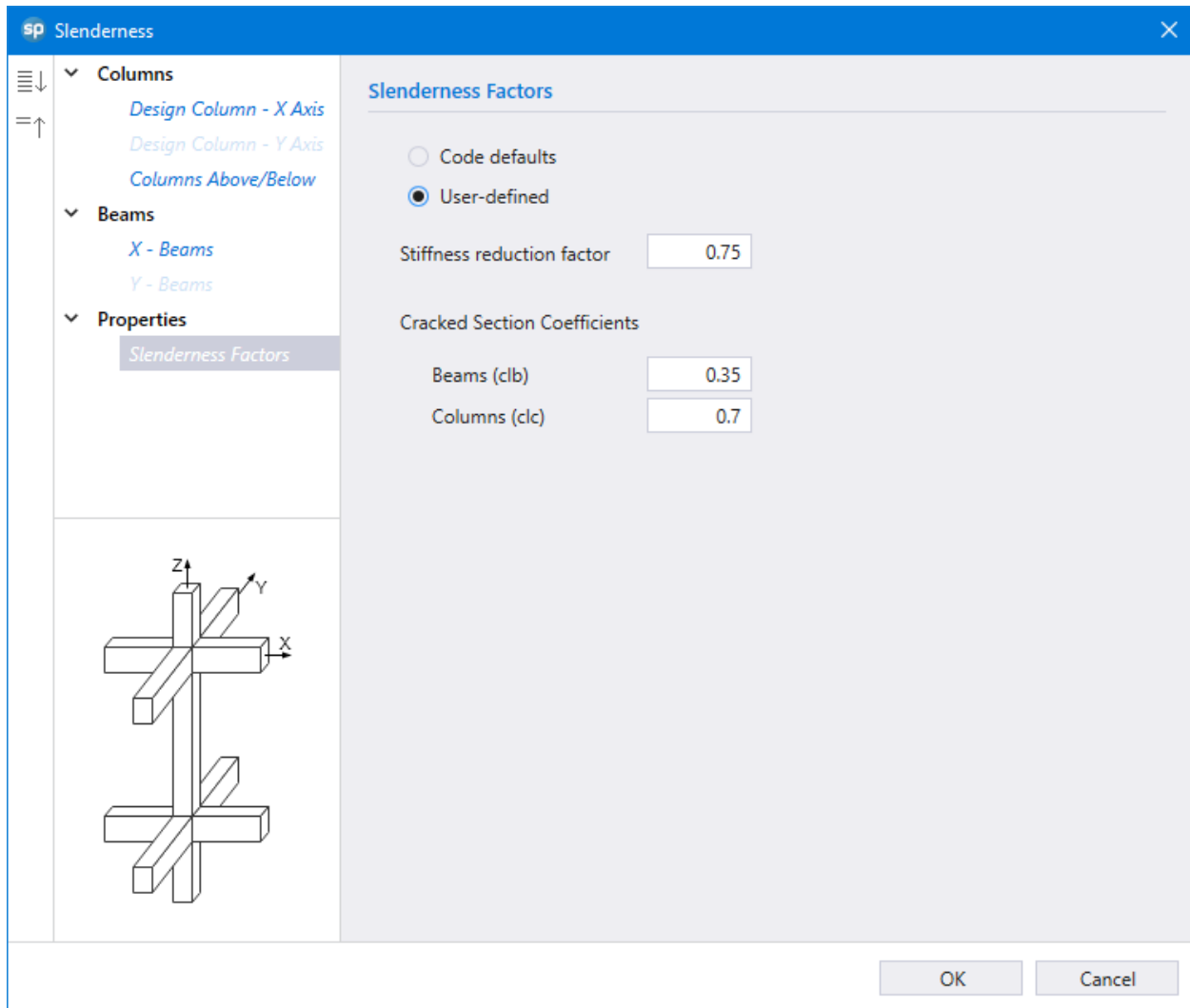

## 5.4. Modeling with Templates

---

This modeling option is currently provided in spColumn v11.00 - Beta and is only available currently to the StructurePoint advanced users group. It will be available for all users when public release is announced by StructurePoint. [Contact](#) StructurePoint to evaluate modeling with templates in advance of public release.

### 5.4.1. Utilizing Templates

TEMPLATES can be accessed from SECTION or from the **Start Screen** under **Projects**.

Utilizing TEMPLATES is a quick and simple option for creating new models in spColumn. Templates can be used in a similar way to REGULAR sections. The user can select from a set of pre-defined templates and edit their properties for simple and quick model generation. Each template focuses on a particular structural shape with specific reinforcement pattern consistent with the shape. The user can edit the geometric dimensions of the shape and the bars properties. Other shape specific options may also be available for some templates.

sp Select section
×

- ▼ Columns
  - Rectangular
  - Circular
- ▼ Walls
  - Rectangular
  - Barbell
  - L, T, I
  - C, E, F
  - Core
- ▼ Piers
  - Rectangular
  - Circular
  - Stadium
  - Others
- User Defined



Stadium

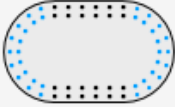

Stadium-MultiLayer

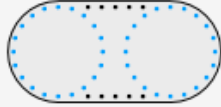

Stadium-Hoops

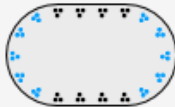

Stadium-Bundled

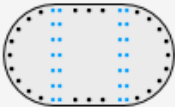





Stadium-InternalLayers

☰ ↓  
☰ ↑

Cancel

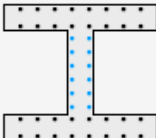
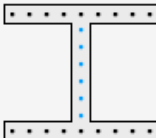
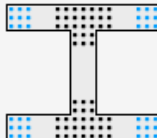
sp Select section
×

- ▼ Columns
  - Rectangular
  - Circular
- ▼ Walls
  - Rectangular
  - Barbell
  - L, T, I
  - C, E, F
  - Core
- ▼ Piers
  - Rectangular
  - Circular
  - Stadium
  - Others
  - User Defined

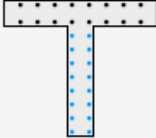
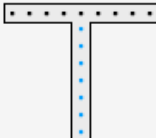
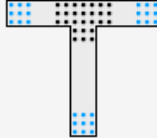
		
I-Perimetric	I-Single	I-Zoned
		
L-Perimetric	L-Single	L-Zoned
		
T-Perimetric	T-Single	T-Zoned

Cancel

## 5.5. Utilizing Predefined Examples

In the **Start Screen** under **Projects** select the **EXAMPLES** option. This will take you to the Examples folder under the spColumn installation directory. If the user is directed to another location on the computer, the user can navigate manually to the Examples file folder located at: C:\Program Files (x86)\StructurePoint\spColumn\Examples

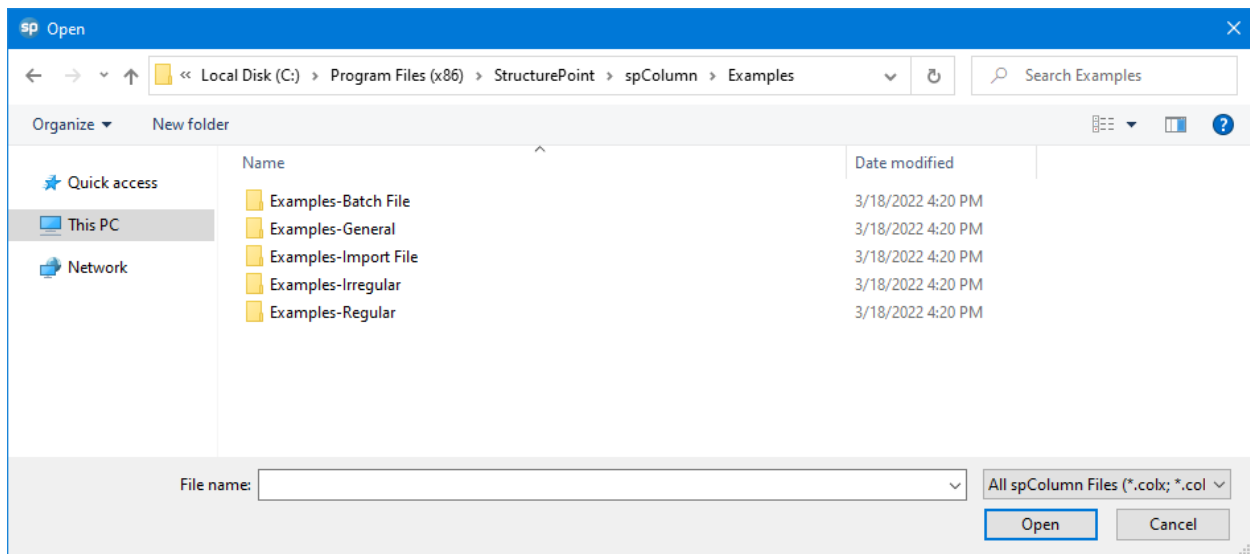

## 5.6. Importing Model Data

spColumn provides multiple options to import SECTION and LOADS data bypassing the standard user interface.

SECTION data can be imported from a:

- Delimited Text File (TXT)
- Drawing Exchange Format file (DXF)

LOADS data can be imported from a

- Delimited Text File (TXT)
- ETABS model - ETABS Exchange Database (EDB)
- Extensible Markup Language (XML)

Import options can be obtained from **File | Import**. Importing a data set will completely replace any existing data of that particular set.

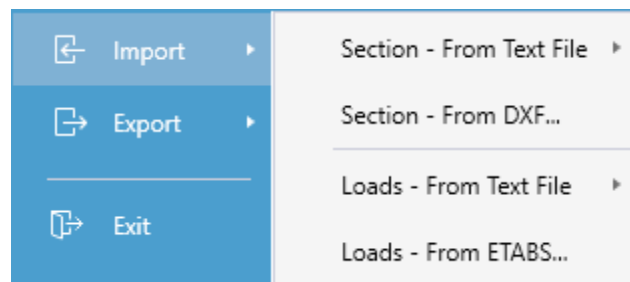

### 5.6.1. Importing Section from Text

Apart from **File | Import**, section data import options are also available in the three-dot overflow menu (...) in the top right of the **Section** left panel. When importing section data from Delimited Text Files (TXT), spColumn provides the options to import the complete SECTION, ONLY GEOMETRY or ONLY REINFORCEMENT. For details on the import file formats please refer to the **Appendix**.

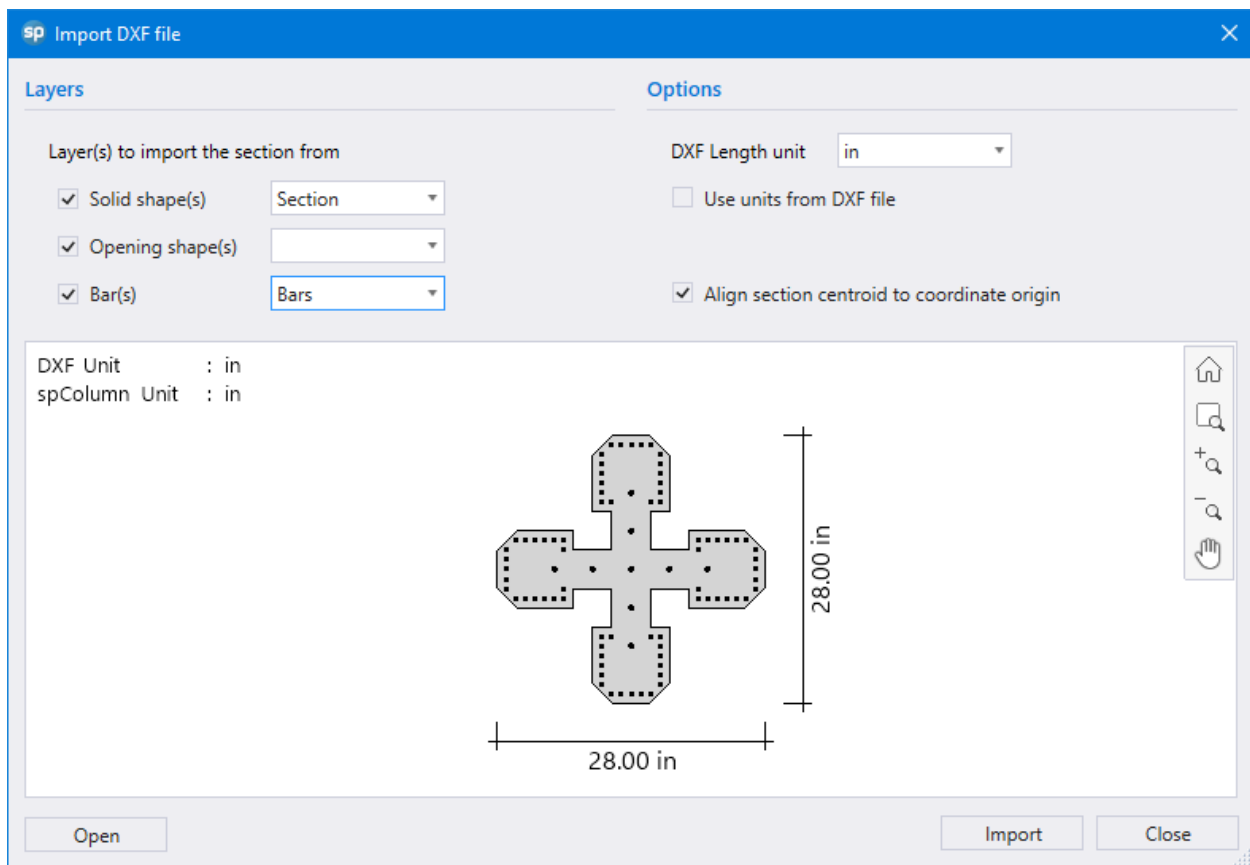

### 5.6.2. Importing Section from DXF

When importing section data from Drawing Exchange Format (DXF) files spColumn only imports the Section, Openings or Reinforcements from the layers selected for each. If the DXF file being imported has the layers SOLIDS, OPENINGS and BARS then the import module automatically selects these layers for Solid shapes(s), Opening shape(s) and Bar(s) respectively. In case of absence of SOLIDS, OPENINGS and BARS layers it is up to the user to select the layers from which to import the various section components. During import, the interpretations of section components are based on the entities available in the selected layers.

- From the layers selected for Solid shapes(s) and/or Opening shapes(s) only Closed POLYLINE, LWPOLYLINE and CIRCLE entities will be interpreted as the section or opening outline. If multiple closed polylines or circles are present then they will be interpreted as multiple sections or openings.
- From the layers selected for Bars(s) only Closed CIRCLE entities will be interpreted as bars.
- Dimensions of imported entities will be automatically converted to current project units based on DXF header variable \$INSUNITS. If the option USE UNIT FROM DXF FILE is unchecked, the DXF file will be assigned the user defined “DXF Length unit” which will then be converted to the current project units.

### 5.6.3. Importing Loads from Text

#### From Delimited Text File (TXT)

Apart from **File | Import**, loads data import options are also available in three-dot overflow menu (...) in the top right of the selected load left panel in LOADS dialog box. spColumn provides the options to import both FACTORED and SERVICE loads. For details on the import file formats please refer to the **Appendix**.

## 5.6.4. Importing Loads from ETABS

### From ETABS

spColumn supports two file formats, EDB and XML, to import **Factored Loads** from ETABS models. The loads can be imported by accessing IMPORT FROM ETABS dialog box from the **File | Import** menu or from the three-dot overflow menu (...) in the top right of the **Factored Loads** dialog box.

If an EDB file is loaded, the program will launch an instance of the latest available version of ETABS application to import the data. The launched ETABS instance will hide but remains connected to spColumn. To avoid running an ETABS instance at a later time, click SAVE MODEL AS XML button to retrieve the required model data. For details on exporting XML files directly from ETABS please refer to the **Appendix**.

After loading the model, the **Members** tab will open:

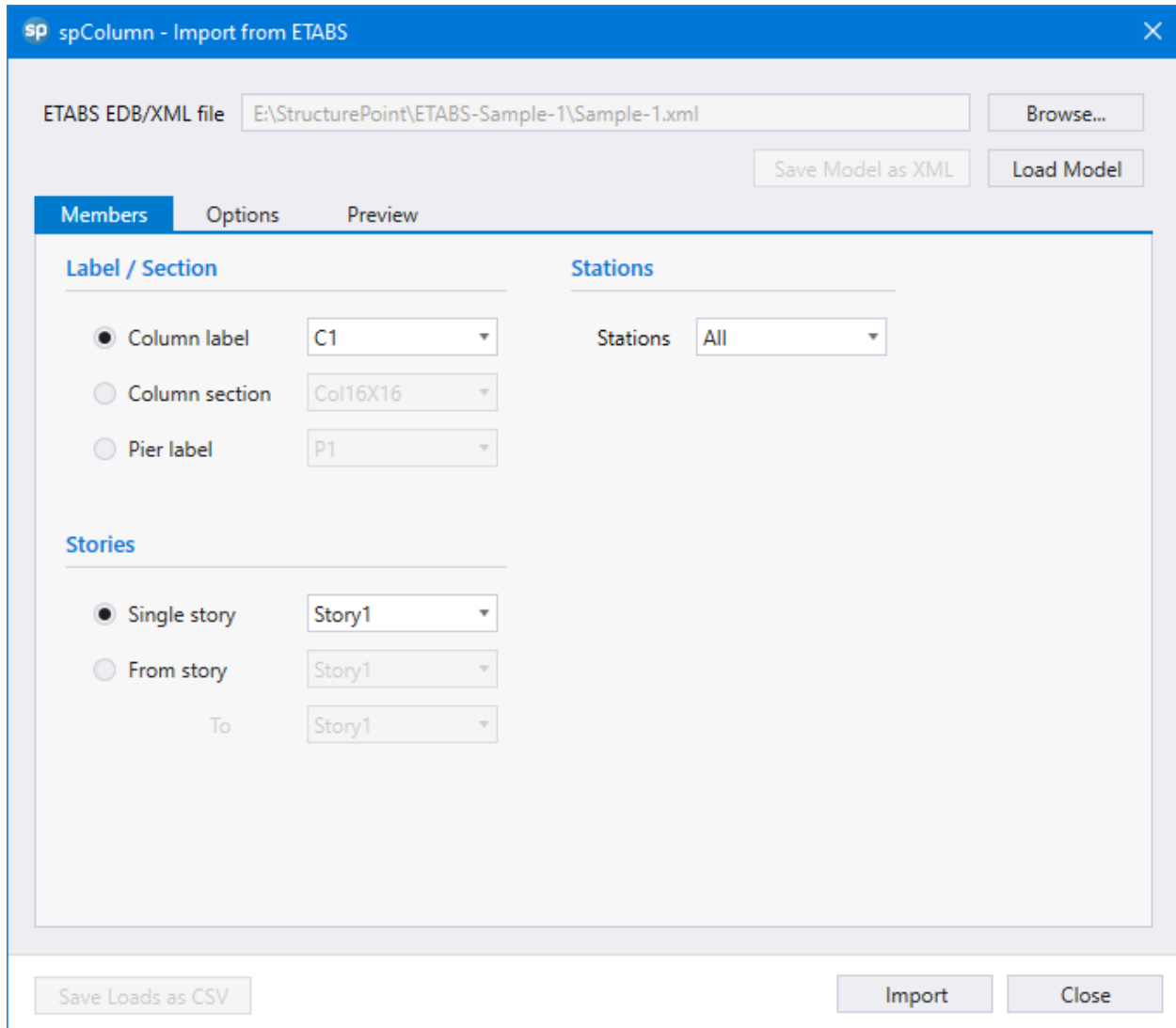

- In the LABEL/SECTION group, select the column or pier that you want to import its loads. Columns can be selected by their assigned labels or sections, but piers can be selected by their assigned labels only.
- In the STORIES group, select if you want to import the member loads for a SINGLE STORY or multiple stories. Then use the drop-down list to select the story number or range of stories to be imported. Note that members are associated with the story level directly above them.
- In the STATIONS group, select the locations you want to import forces from. The forces are output at the TOP, bottom (BOT.), or TOP & BOT. of columns and piers. Column forces can also be imported for multiple output-stations located along the member's length using the option ALL.

Open **Options** tab to select load COMBINATIONS and CASES:

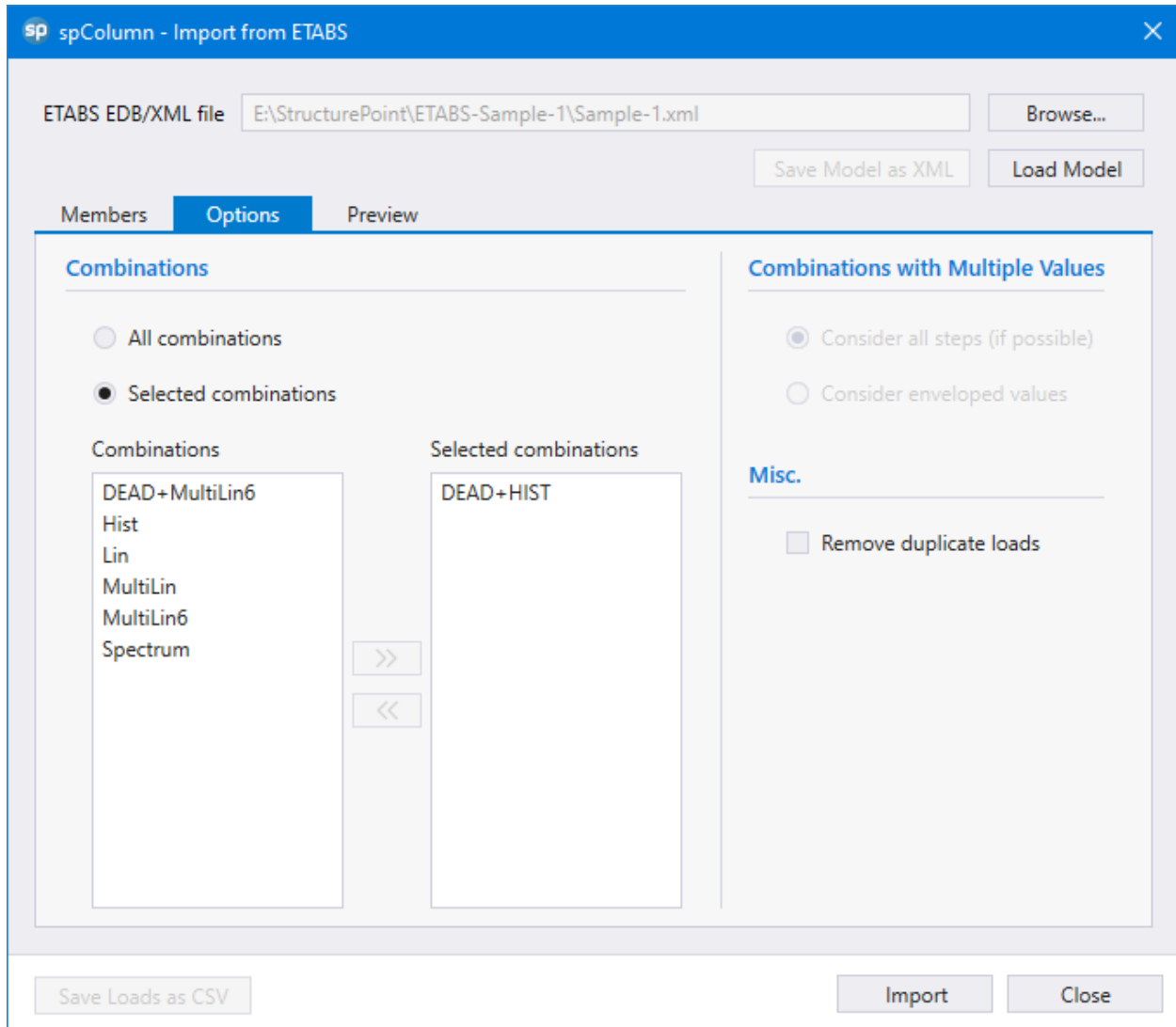

- In the COMBINATIONS group, select if you want to import the loads for ALL COMBINATIONS or SELECTED COMBINATIONS. By default, ALL COMBINATIONS is selected. If you choose SELECTED COMBINATIONS, you can use the dual list-box to choose specific load combinations. After selecting a combination, use the arrows << or >> to move your selection between lists.
- In the CASES WITH MULTIPLE VALUES, select if you want to consider ALL STEPS or ENVELOPED VALUES only. By default, CONSIDER ALL STEPS is selected. If you select CONSIDER ALL STEPS, the forces are imported for every step in all applicable directions. Multiple values are available for Direct-Integration Time-History analysis, Modal Time-History analysis, and Multi-Step Linear

Static analysis. If you select CONSIDER ENVELOPED VALUES, only the extreme values will be imported for multi-step load combinations. Enveloped results are imported for all permutations of minimum and maximum values of  $P$ ,  $M_x$  and  $M_y$ .

The direction of imported forces and moments is transformed from a members' local 1-2-3 coordinate system in ETABS to the global x-y-z system of applied factored loads in spColumn. Axial forces along member length are transformed from positive under tension in the first local axis to positive under compression in the global axis ( $P_z = -P_1$ ). The remaining two axes lie on a plane perpendicular to the positive axial direction and are right-handed in both systems ( $M_y = -M_2$ ,  $M_x = -M_3$ )

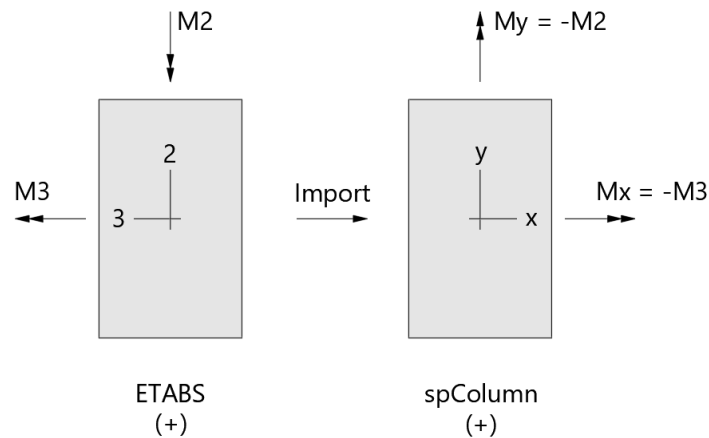

The **Preview** tab displays a table of factored loads for the selected members and load combinations.

Once spColumn has finished importing the file, you will be provided with a message box similar to the one shown below:

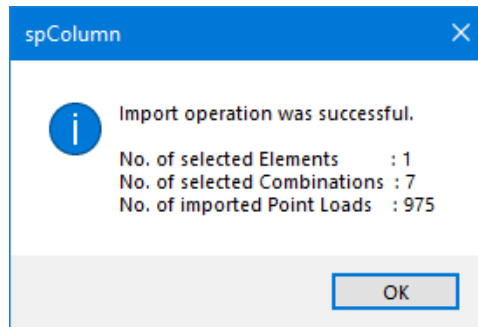

It should be noted that importing a data set will completely replace existing data of that particular set in the program. For details on the import file formats please refer to the Appendix.

## 5.7. Exporting Model Data

spColumn provides the options to export SECTION, LOADS and DIAGRAMS data. Both SECTION and LOADS data can be exported to a Delimited Text (TXT) File. Section data can also be exported to Drawing Exchange Format (DXF) file. The export options can be obtained from **File | Export**

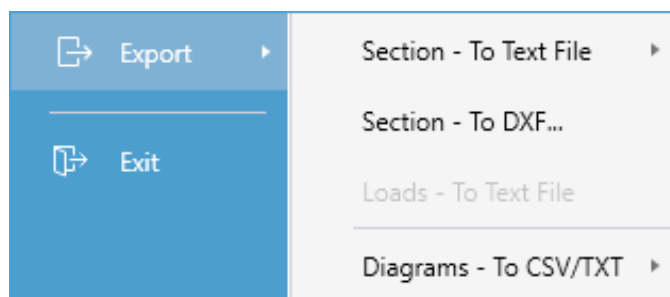

### 5.7.1. Exporting Section Data

The section data export options are available under **File | Export** or the three-dot overflow menu (...) in the top right of the **Section** left panel. When exporting to a DXF, the program automatically exports the Solids, Openings and Bars into three different layers with corresponding names as the section components. The exported DXF file is readable by most CAD software. When exporting to a TXT the program offers to export the complete SECTION, ONLY GEOMETRY or ONLY REINFORCEMENT.

### 5.7.2. Exporting Loads Data

spColumn provides the options to export loads data to a Delimited Text file. The active load data can be exported by selecting LOADS – TO TEXT FILE... under **File | Export** or from the three dot overflow menu (...) in the top right of the selected load left panel in LOADS dialog box.

For both sections and loads the exported TXT data format will be the same as the import data format provided in the **Appendix**.

### 5.7.3. Exporting Diagrams

Once a successful run has been performed, DIAGRAMS can be exported as data files or graphical reports. Options to export diagrams as data files are available in **File | Export**.

- Points from the interaction diagrams or 3D failure surface can be exported to a Comma-Separated Values (CSV) file or a Tab Delimited Text file (TXT). These files can be read by most spreadsheet and mathematical programs where data produced by spColumn can be further analyzed and processed as needed by the user. Coordinates of the points ( $P$ ,  $M_x$ ,  $M_y$ ) are saved together with corresponding location of the neutral axis (depth and angle), maximum steel strain, and, for ACI code, strength reduction factor. The following options are available:
- FACTORED INTERACTION DIAGRAM to export P-M or  $M_x$ - $M_y$  diagram currently displayed on the screen.
- FACTORED 3D FAILURE SURFACE to export 3D failure surface. Available for biaxial runs only.
- NOMINAL INTERACTION DIAGRAM to export nominal (unfactored) P-M or  $M_x$ - $M_y$  diagram corresponding to the one currently displayed on the screen.
- NOMINAL 3D FAILURE SURFACE to export nominal (unfactored) 3D failure surface. Available for biaxial runs only.
- 2D interaction diagrams and contours can be copied to the clipboard to be pasted elsewhere by using the **Copy to Clipboard** command in the menu obtained by right clicking on a viewport displaying 2D diagrams.
- Graphical reports can be exported to a file in Enhanced Metafile Format (EMF) or Bitmap Format (BMP) that is readable by most graphics and word processing programs. The file will include column section, column information, and the interaction diagram currently displayed on the view screen. For additional details on how to export graphical reports check the tutorial available online for the Print/Export Module.

CHAPTER

6

## MODEL SOLUTION

---

Once the model creation and development are completed, the design or investigation of the completed model can begin using the spColumn Solver by choosing one of several methods of running the model. The choice depends on the user preference for design or investigation of the model as well as to run from within the program user interface or via the external API using the Column Text Input (CTI). In all cases the user may **Solve** models individually or in batch mode to facilitate and expedite running multiple models at once.

## 6.1. Running from program

Once the model creation is complete, the **Solve** command can be used to run the solver. The solution steps being carried out are displayed in the Solver dialog.

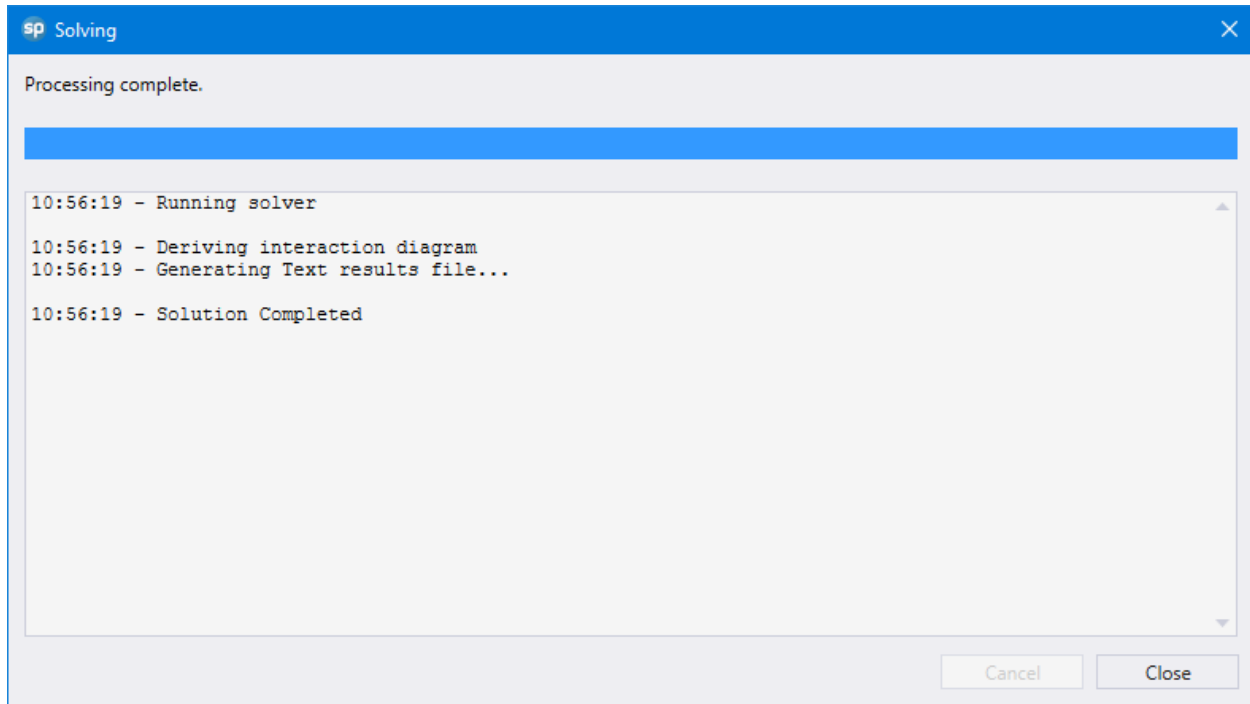

After a successful run the program directly switches to the diagram scope. If, however, the solution procedure is interrupted by errors or warnings, a dialog box appears communicating relevant messages to the user regarding any concerns or issues. The results will not show until successful completion of the analysis.

The user can refer to **Solver Messages** table in the **Tables** module to see additional details of the solution progress or warning and errors, if any.

### Warnings and Errors

Every warning and error should be carefully reviewed by an Engineer as it may have a significant influence on the design results and outcomes. It is essential to understand the reason behind the warnings and errors in order to properly mitigate the issues or make the necessary adjustments to the model under consideration. While some topics are clear in the prompt message as to what is

required to be adjusted by the user, others are fundamental theoretical issues that need a thorough understanding of the issue and its cause in order to properly resolve it.

Model warnings can be bypassed at the user discretion. The program provides the option to continue with the solution in the warning message box. If the user chooses to continue with the solution despite the warning, it is suggested that the user review the results for accuracy and take the responsibility to examine the impact of the violated parameters. Presence of errors in the model will terminate the solver and the model will have to be modified with relevant changes before a solution can be obtained.

Some of the most frequent warnings and errors are listed below along with a brief description.

### **Frequent Warnings**

- Reinforcement ratio is less than 1%.
- Reinforcement ratio exceeds 8%.
- Bar outside of section present. Numerical instabilities may be encountered.
- Section capacity exceeded - This results when the calculated section capacity is less than the loads applied on it.
- Cannot achieve desired accuracy - This results when the program cannot meet the predefined convergence criteria and the corresponding point on the interaction diagram may be slightly off.
- Slenderness  $k \times \ell_u / r$  is greater than 100 - This results when slenderness effects cannot be accounted for using moment magnification procedure.
- Magnified (second-order) moment exceeds 1.4 times first-order moment - This results when the value of total magnified moment including second-order effects exceeds 1.4 times the corresponding moment due to first order effects

**Frequent Errors**

- Need Loads data - In Design Mode, the loads need to be specified. If the model is run without any loads being specified, the following error message appears during the run.
- Applied load is greater than buckling load. - This results when the applied load is greater than the critical buckling load,  $P_c$  of the column.

## 6.2. Running with Batch Processor

spColumn solver can also be run in batch mode using the **Batch Processor** module. Multiple models can be designed and analyzed at once by loading more than one file into the **Batch Processor** module. The desired report format, export file types and solve options can also be selected from the module before invoking the solver. **Batch Processor** module can be utilized along with Column Text Input files (CTI) for automating spColumn runs for projects with large numbers of sections.

After a successful run, a message box will display a brief summary of the Run status. Solution status, section information and capacity ratios (C.R.) for each analyzed section are displayed in the module data grid and exported to a summary file *\_Batch Processing Report.csv* with additional details on warnings and errors.

Data Folder: E:\StructurePoint\spColumn\Examples-Manual

Report Type:  Word,  Excel,  Text,  PDF,  CSV

Export:  Section to DXF file,  Model to Text file (CTI)

Options:  If Rho < 1% - Consider column as Architectural,  If Rho > 8% - Solve the model

Processing 6 of 6

No.	File Name	Status	Section	Size / Diameter	Rho (%)	C.R.
1	Example01.col	Ok	Rectangular	16.00 x 16.00 in	1.23	-
2	Example02.col	Ok	Rectangular	20.00 x 14.00 in	3.34	0.83
3	Example03.col	Ok	Rectangular	18.00 x 18.00 in	4.70	0.60
4	Example04.col	Ok	Irregular	15.00 x 144.00 in	0.97 #	-
5	Example05.col	Warning(s)	Irregular	24.00 x 24.00 in	0.77 #	1.08 #
6	Example06.col	Ok	Rectangular	350 x 200 mm	1.71	0.96

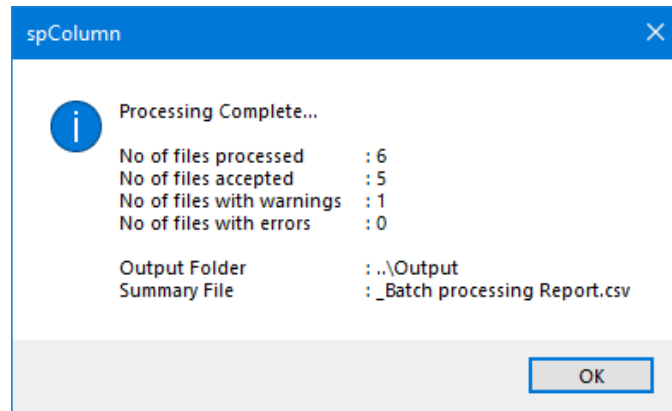

The ORGANIZE feature will create two new folders: “Accepted Data files” and “Accepted Output files” and organize all the input files and corresponding output files of models without errors and warnings into the folders, respectively.

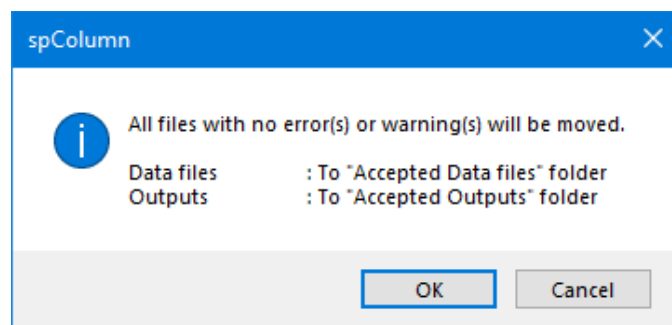

## 6.3. Running from command prompt

spColumn solver can be run in batch mode from the command line prompt. Command line runs can be done by invoking **spColumn.CLI.exe** (spColumn Command Line Interface module) after navigating to the directory in which spColumn is installed. Input data file, output data file, and run options can be passed to the program via parameters. For instance, when in the command prompt, navigating to the directory containing spColumn.CLI.exe and typing

```
spColumn.CLI /i:Examples\Examples-General\Example01.colx
```

will run spColumn and solve the model defined in the input file Example01.colx. Each step of the solve process and its timestamp along with color coded Errors and/or Warnings, if any, will also be listed.

By using the /batch parameter the batch processor module can be invoked in the command line. This facilitates passing a directory containing several input files instead of passing the files one by one. For instance, when in the command prompt, navigating to the directory containing spColumn.CLI.exe and typing

```
spColumn.CLI /i:Examples\Examples-General /batch
```

will invoke the spColumn batch processor module and solve all valid input files within the Examples-General folder. Once complete, a summary report in csv format is generated with the run information of each input file in the directory.

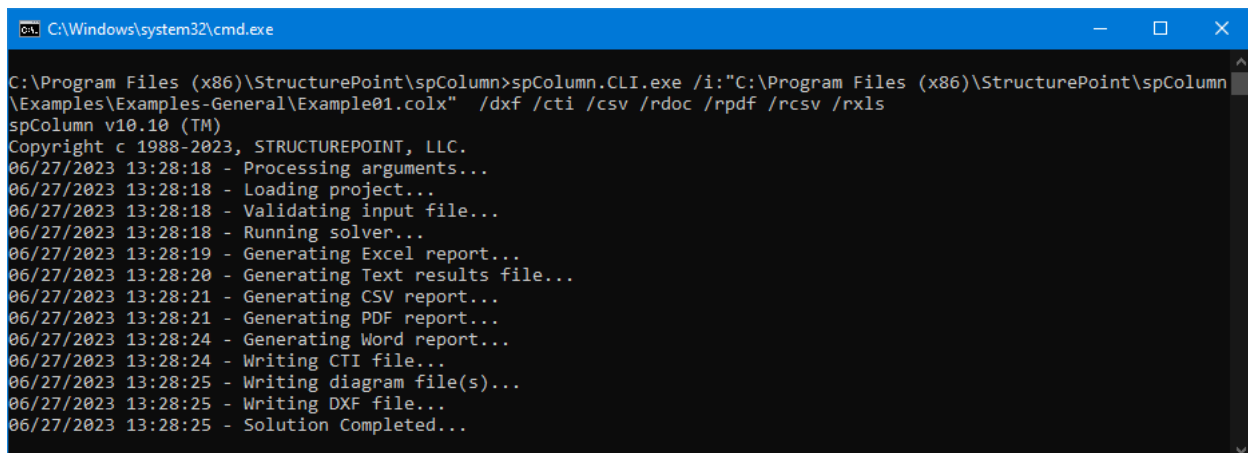

```
C:\Windows\system32\cmd.exe
C:\Program Files (x86)\StructurePoint\spColumn>spColumn.CLI.exe /i:"C:\Program Files (x86)\StructurePoint\spColumn
\Examples\Examples-General\Example01.colx" /dxf /cti /csv /rdoc /rpdf /rcsv /rxls
spColumn v10.10 (TM)
Copyright c 1988-2023, STRUCTUREPOINT, LLC.
06/27/2023 13:28:18 - Processing arguments...
06/27/2023 13:28:18 - Loading project...
06/27/2023 13:28:18 - Validating input file...
06/27/2023 13:28:18 - Running solver...
06/27/2023 13:28:19 - Generating Excel report...
06/27/2023 13:28:20 - Generating Text results file...
06/27/2023 13:28:21 - Generating CSV report...
06/27/2023 13:28:21 - Generating PDF report...
06/27/2023 13:28:24 - Generating Word report...
06/27/2023 13:28:24 - Writing CTI file...
06/27/2023 13:28:25 - Writing diagram file(s)...
06/27/2023 13:28:25 - Writing DXF file...
06/27/2023 13:28:25 - Solution Completed...
```

Multiple cross-sections can be designed and analyzed by running spColumn with multiple input files using batch (BAT) files (see Examples.bat in the spColumn program folder). Combined with Column Text Input files (CTI), this feature can be used for automating spColumn runs for projects involving large numbers of cross-sections.

Help on how to use command line parameters can be obtained by typing `spColumn.CLI /?` or `spColumn.CLI /help` at the command prompt.

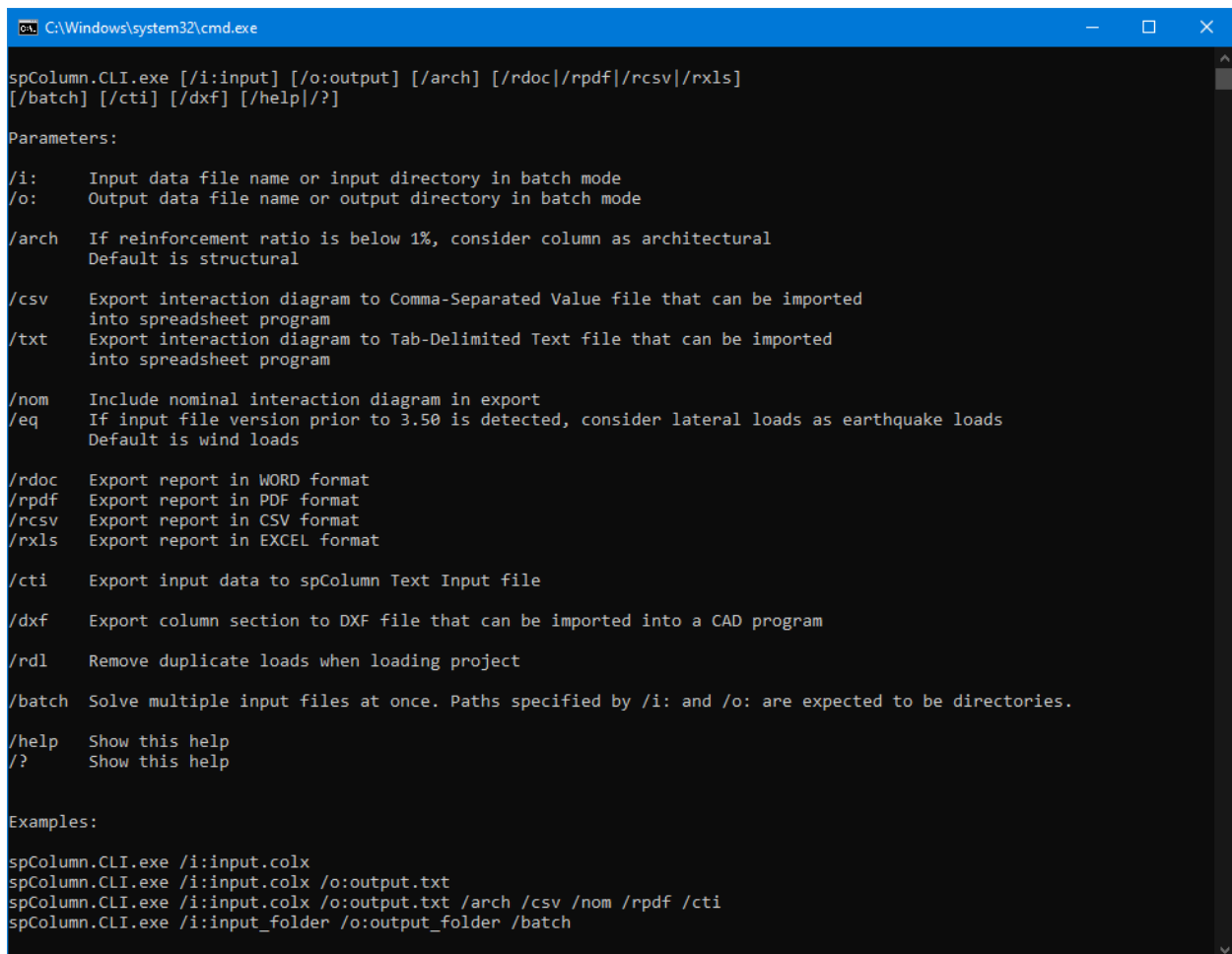

```

C:\Windows\system32\cmd.exe
spColumn.CLI.exe [/i:input] [/o:output] [/arch] [/rdoc|/rpdf|/rcsv|/rxls]
[/batch] [/cti] [/dx] [/help|/?]

Parameters:

/i:      Input data file name or input directory in batch mode
/o:      Output data file name or output directory in batch mode

/arch   If reinforcement ratio is below 1%, consider column as architectural
        Default is structural

/csv    Export interaction diagram to Comma-Separated Value file that can be imported
        into spreadsheet program
/txt    Export interaction diagram to Tab-Delimited Text file that can be imported
        into spreadsheet program

/nom    Include nominal interaction diagram in export
/eq     If input file version prior to 3.50 is detected, consider lateral loads as earthquake loads
        Default is wind loads

/rdoc   Export report in WORD format
/rpdf   Export report in PDF format
/rcsv   Export report in CSV format
/rxls   Export report in EXCEL format

/cti    Export input data to spColumn Text Input file

/dx     Export column section to DXF file that can be imported into a CAD program

/rdl    Remove duplicate loads when loading project

/batch  Solve multiple input files at once. Paths specified by /i: and /o: are expected to be directories.

/help   Show this help
/?     Show this help

Examples:

spColumn.CLI.exe /i:input.colx
spColumn.CLI.exe /i:input.colx /o:output.txt
spColumn.CLI.exe /i:input.colx /o:output.txt /arch /csv /nom /rpdf /cti
spColumn.CLI.exe /i:input_folder /o:output_folder /batch
    
```

## CHAPTER

## 7

# MODEL OUTPUT

---

The results of the analysis are presented as two types of outputs

- **Tabular Output** with result tables including all relevant exact numerical results.
- **Graphical Output** with interaction diagrams, contours and 3D failure surfaces

This chapter provides a detailed description of the output types along with their respective features and settings.

## 7.1. Tabular Output

---

The Tabular output can be found both in the **Tables Module** and the **Reporter Module**. Before a problem is solved, tabular outputs consist of only the input data tables; tables related to results are added after a successful solve. The **Tables Module** may be utilized to view the model output in a fast and convenient way. It also facilitates the exporting of tables that are actively being viewed.

The **Reporter Module** may be utilized to create, export and print customized reports. Both modules have the same output sections. The differences being that the **Reporter Module** contains the cover & contents, and diagrams sections.

The Tabular output contains the following common input and results sections:

### 7.1.1. Input

This section contains the following input subsections and data blocks:

#### General Information

This data block contains the information regarding to the **Project** input entered by the user.

#### Material Properties

This subsection contains the information regarding to the **Material Properties** input entered by the user. This subsection has data blocks for CONCRETE and STEEL input data.

#### Section

This subsection contains the information regarding to the section input entered by the user. This subsection has data blocks for SHAPE and PROPERTIES, SECTION  $\epsilon$ , SOLIDS and OPENINGS input data.

### Reinforcement

This subsection contains the information regarding the Reinforcement input data. This subsection has data blocks for BAR SET, DESIGN CRITERIA, CONFINEMENT AND FACTORS, ARRANGEMENT, and BARS PROVIDED input data.

### Loading

This subsection contains the information regarding the Loading input data. This subsection has data blocks for LOAD CASES, LOAD COMBINATIONS, and SERVICE LOADS input data.

### Slenderness

This subsection contains the information regarding to the Slenderness input data. This subsection has data blocks for SWAY CRITERIA, COLUMNS, X-BEAMS and Y-BEAMS input data.

### 7.1.2. Results

This section contains the following results subsections and data blocks.

#### Moment Magnification

This subsection contains output for the Moment Magnification results. This subsection has data blocks for GENERAL PARAMETERS, EFFECTIVE LENGTH FACTORS, MAGNIFICATION FACTORS: X- AXIS, and MAGNIFICATION FACTORS: Y-AXIS.

#### Factored Moments

This subsection contains output for the Factored Moments results. This subsection has data blocks for X-axis and Y-axis.

#### Control Points

This block contains output for Control Points results.

#### Loads and Capacities

This block contains output for Loads and Capacities results when the Axial Load feature is being used to determine the moment capacity of the column at different axial loads.

#### Loads and Capacity Ratios

This block contains output for Loads and Capacity ratios results when Service or Factored loads are being used.

The **Reporter** module also consists of the **Diagrams** block. Diagrams that have been selected to be automatically included in the report (as set in the program settings) are listed here. Preview of the diagrams in this block can only be seen while viewing the report in Word or PDF formats.

---

## 7.2. Graphical Output

---

The graphical output is available in the DIAGRAMS scope of the program. It is organized into 2D interaction diagrams and contours and 3D failure surfaces. After a successful run the program produces the following types of graphical outputs

- PM interaction diagrams
- $M_x - M_y$  contours (biaxial runs only)
- 3D failure surfaces (biaxial runs only)

Load points are also a part of the graphical output. When factored or service loads are used in the model, they are shown as load points in the above three outputs.

Once the SOLVE button in the ribbon has been used to complete a successful run, the program automatically switches to Diagrams scope. If a solution already exists then diagrams scope can be accessed by clicking the active DIAGRAMS button in the ribbon.

In the DIAGRAMS scope, the Diagrams Left Panel and the Left Panel Toolbar can be used to view and navigate through the graphical output. The four commands at the top of the Diagrams Left Panel can be used to switch between the diagram types being displayed in a viewport.

**DIAGRAMS**

  
PM

  
MM

  
3D-PM

  
3D-MM

**NAVIGATION**

Angle (Mx, My)  < > deg

Axial load  v ^ kip

No.	Load	Combo		Pu	Mux	Muy	Capacity
				kip	k-ft	k-ft	Ratio
1	1	U1	Top	7.0	14.0	28.0	0.31
2	1	U1	Bot	7.0	-21.0	-35.0	0.40
3	1	U2	Top	33.2	37.6	46.4	0.51
4	1	U2	Bot	33.2	-42.0	-50.8	0.56
5	1	U3	Top	23.0	28.0	38.0	0.42

**PROPERTIES**

f'c	4	ksi
fy	60	ksi
Gross area	256	in <sup>2</sup>
Total As	3.16	in <sup>2</sup>
Rho	1.23	%
Max. capacity ratio	0.56	

**SECTION**

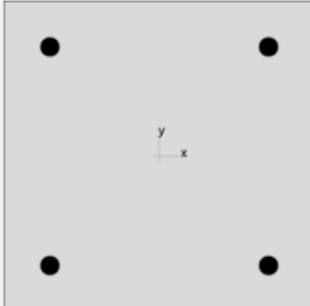

Rectangular 16 x 16 in

## 7.2.1. Diagram Types



### PM Interaction Diagrams

For uniaxial runs the program computes and displays only the PM interaction diagram. For biaxial runs, PM interaction diagrams are created by slicing the calculated 3D failure surface vertically.

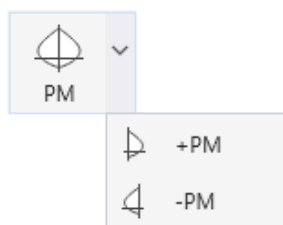
Clicking the PM button in the diagrams left panel prompts the active viewport to display the PM interaction diagram. It is also possible to evaluate only the positive or negative sides of the P-M diagram using the +PM or -PM sub commands of the PM command.



PM interaction diagrams created by slicing the 3D failure surface can be navigated using the **Angle** ( $M_x, M_y$ ) option in the diagrams left panel. This controls the rotation of the vertical plane in the 3D surface, which indicates the location of the P-M interaction diagram.



- To view the desired P-M diagram enter the angle value or select an angle from the dropdown list.
- You can browse through the existing angle values by using   buttons adjacent to the box containing them. The existing angle values are the angles produced by the values of the moments of provided load points.

### **$M_x - M_y$ Contours (Biaxial runs only)**

$M_x - M_y$  contours are available for biaxial runs only. These contours are created by slicing the calculated 3D failure surface horizontally.

Clicking the MM button in the diagrams left panel prompts the active viewport to display the MM contours.

( $M_x, M_y$ ) contours can be navigated using the **Axial load** option in the diagrams left panel. This controls the elevation of the horizontal plane in the 3D surface, which indicates the location of the contour.

- To view the desired contour, enter the axial load value or select an axial load from the drop-down list.
- You can browse through the existing axial load values by using   buttons adjacent to the box containing the axial load values. The existing axial load values are the axial loads of the provided load points.

### 3D Failure Surfaces (Biaxial runs only)

3D failure surfaces are calculated for biaxial runs only.

Clicking the 3D-PM button in the diagrams left panel prompts the active viewport to display the 3D failure surface with a vertical guide plane. The 3D-MM button prompts the active viewport to display the 3D failure surface with a horizontal guide plane.

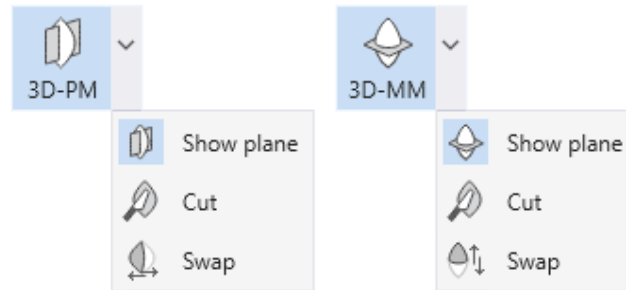

The guide planes can be toggled on/off using the **Show plane** button.

- To cut the 3D failure surface at the location of the guide planes make sure that the guide planes are visible and rotated to the desired angle (or located at the desired axial load) and use the **Cut** command.
- To swap the portion of the 3D diagram visible after the cut, use the **Swap** command.

The commands **PM**, **MM**, **3D-PM** and **3D-MM** and their sub commands are also available in the right click menu of the viewports.

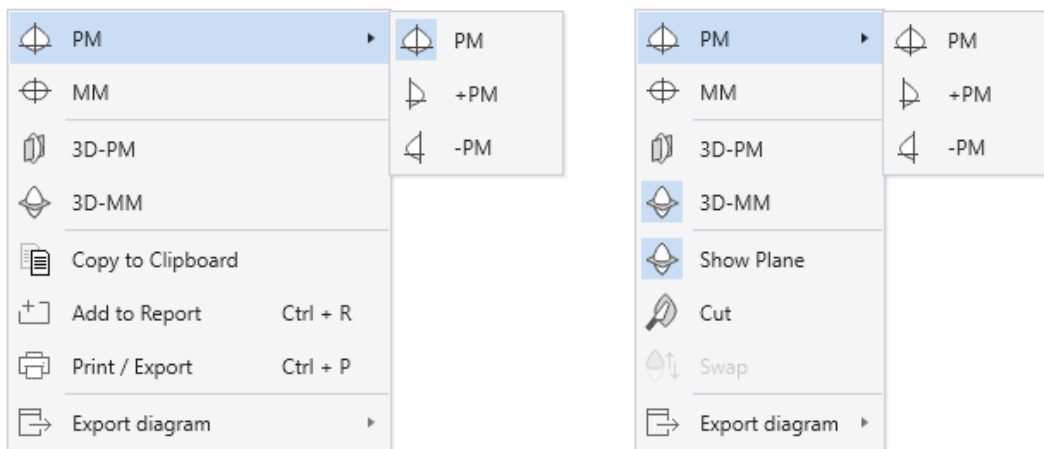

Using **Copy to Clipboard**, **Add to Report** and **Print/Export** commands in the right click menu in viewports displaying 2D diagrams, it is possible to copy the displayed 2D diagram to the clipboard, add the diagram to the report or import it into the Print/Export module for further formatting and customization.

The **Export diagram** feature in the right click menu allows exporting the active factored and/or nominal 2D diagrams and the 3D surfaces as a CSV or TXT file.

## Load Points

Load points are displayed both in the 2D diagrams and contours and the 3D surfaces.

- To investigate a load point, click on the desired load point in the load point list immediately below the **Angle** and **Axial load** options. This creates P-M interaction diagram and ( $M_x$ ,  $M_y$ ) contours at the load point location and also highlights the selected load point for easy observation.

Alternatively, you can also directly click on a load point in the diagram and view its associated angle, axial load and load point details in the diagrams left panel.

- To view details about the load point, right click on the desired load point in the 2D or 3D viewports. This shows the LOAD POINT dialog box with all essential parameters related to the load point.

SP Load Point
✕

**Load Point**

Point No.	1
Load No.	1
Combination	U1
Location	Top
Pu	115.00 kip
M(ux)	11.50 k-ft
M(uy)	293.00 k-ft
Capacity Ratio	0.83

**Capacity Point**

$\Phi$ Pn	115.01 kip
$\Phi$ Mnx	13.89 k-ft
$\Phi$ Mny	354.52 k-ft

The **Filter command** located in the **Left Panel Toolbar** can be used to filter the load points in the load points list and the diagrams based on load point location, capacity ratio and presence in diagram.

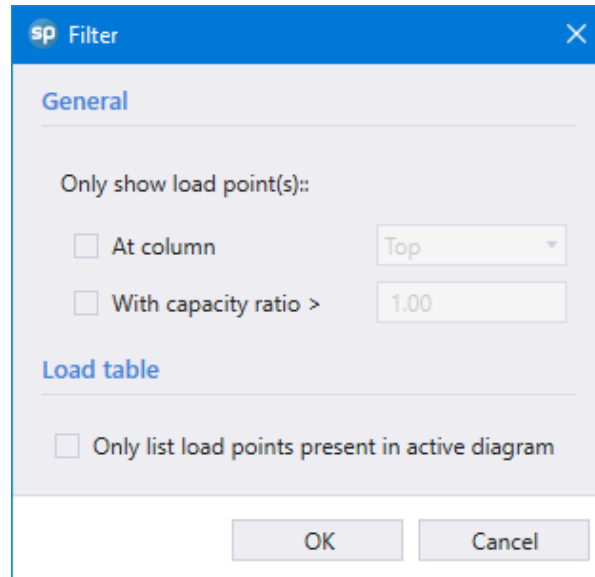

## 7.2.2. Viewing Aids

Viewing aids are those features in the program that facilitate viewing the graphical output results produced by the program.

### Multiple Viewports

For biaxial runs only, multiple viewports can be used to view different diagrams at the same time. The **Viewports** Command in the **Ribbon** can be used to select from a set of pre-defined viewport configurations or create a new viewport window. A maximum of 6 viewports can be used at one time.

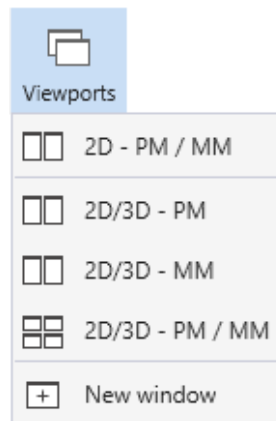

## View Controls

When a viewport is active it has a set of **View Controls** located in the top right corner. These commands can be used to aid in viewing the 2D diagrams or 3D surfaces. Commands listed in the **View Controls** vary depending on if the viewport is displaying 2D diagrams or 3D surfaces.

In case of viewports displaying 2D diagrams, commands in the **View Controls** can be used to ZOOM TO THE WORKSPACE, ZOOM TO WINDOW, ZOOM IN, ZOOM OUT, PAN and TOGGLE the diagram Grid on/off.

For viewports displaying 3D SURFACES, VIEW CONTROLS, apart from ZOOM TO THE WORKSPACE, ZOOM IN, ZOOM OUT and PAN, also contain commands for:

- Rotate Section in 3D: Enables rotating the 3D surfaces in three dimensions (shift + middle mouse button)
- Free guide plane control: Enables free movement of horizontal and vertical guide planes

Contents in both the viewports can be zoomed in and zoomed out using the mouse wheel and panned by holding the middle mouse button and moving the mouse around.



## Display Options

The **Display** Command in the **Ribbon** can be used to open the DISPLAY OPTIONS dialog. This dialog facilitates toggling on/off the different Diagram Types and Diagram Elements for both 2D diagrams and 3D surfaces.

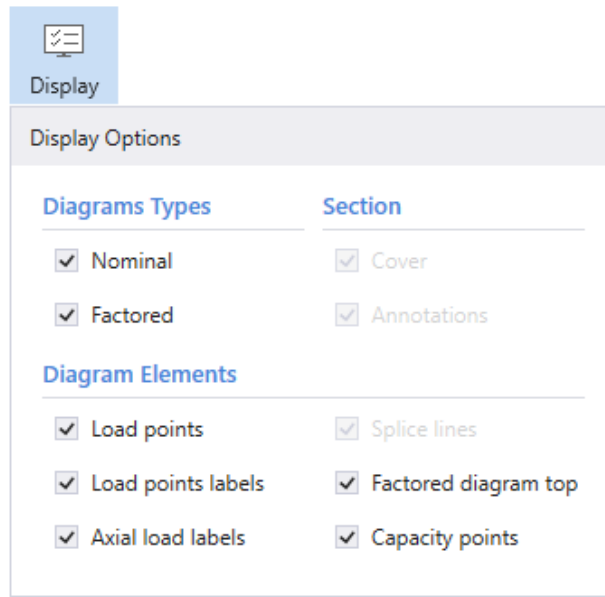

## 7.3. Output Settings

---

The **Settings** Command in the **Ribbon** can be used to open the SETTINGS dialog which can be used to change various program settings. The settings dialog can also be accessed from the settings button at the bottom left of the start screen. Beyond general options and program startup default values the settings provide the user with numerous ways to personalize results reports as well as 2D and 3D diagrams.

### 7.3.1. Settings – Tabular Results

Tabular results settings are simply obtained from the ribbon to provide user options for result tables and reports as follows:

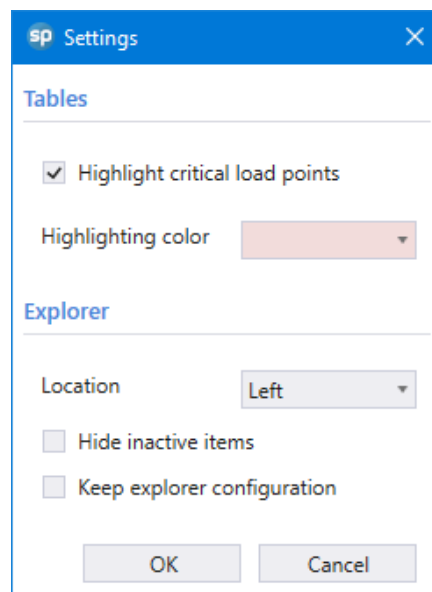
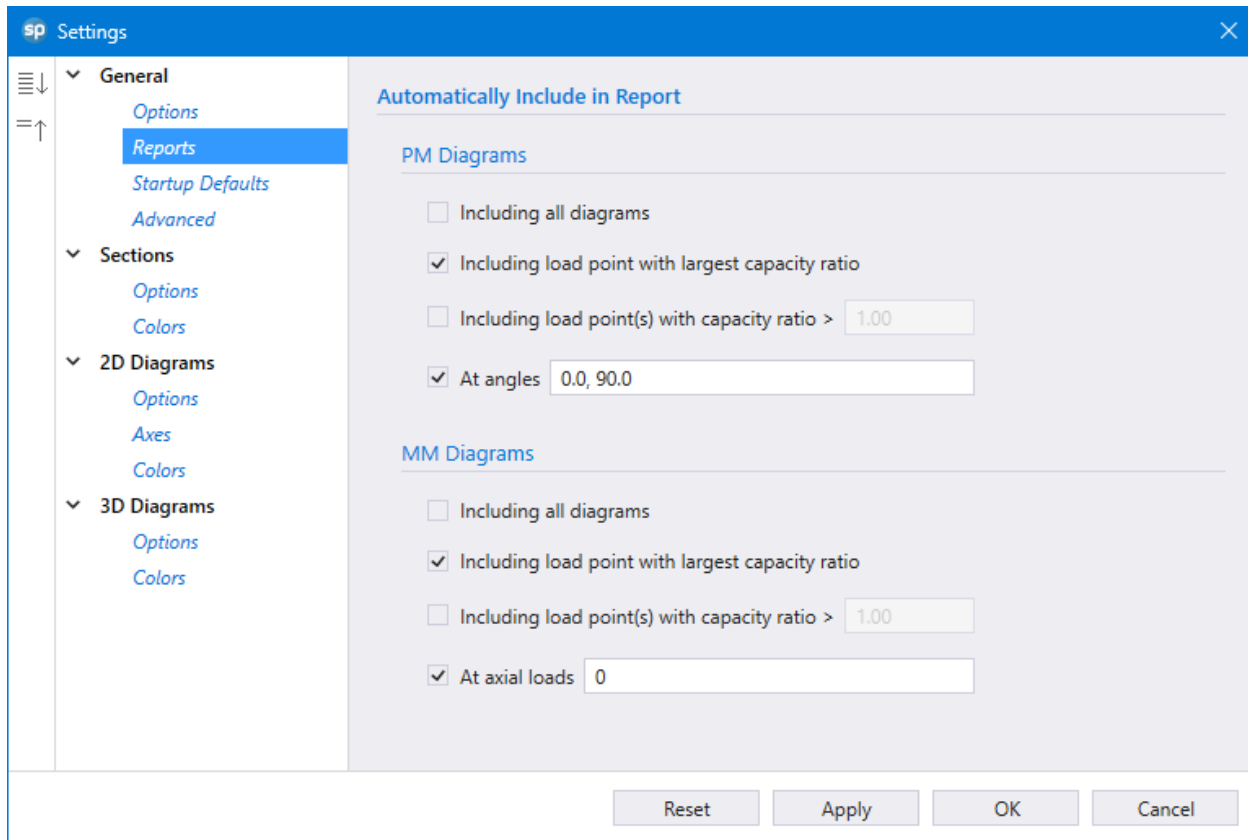

### 7.3.2. Settings – 2D Diagram

Provides users with the options to modify Options, Axes and Color settings for 2D diagrams.

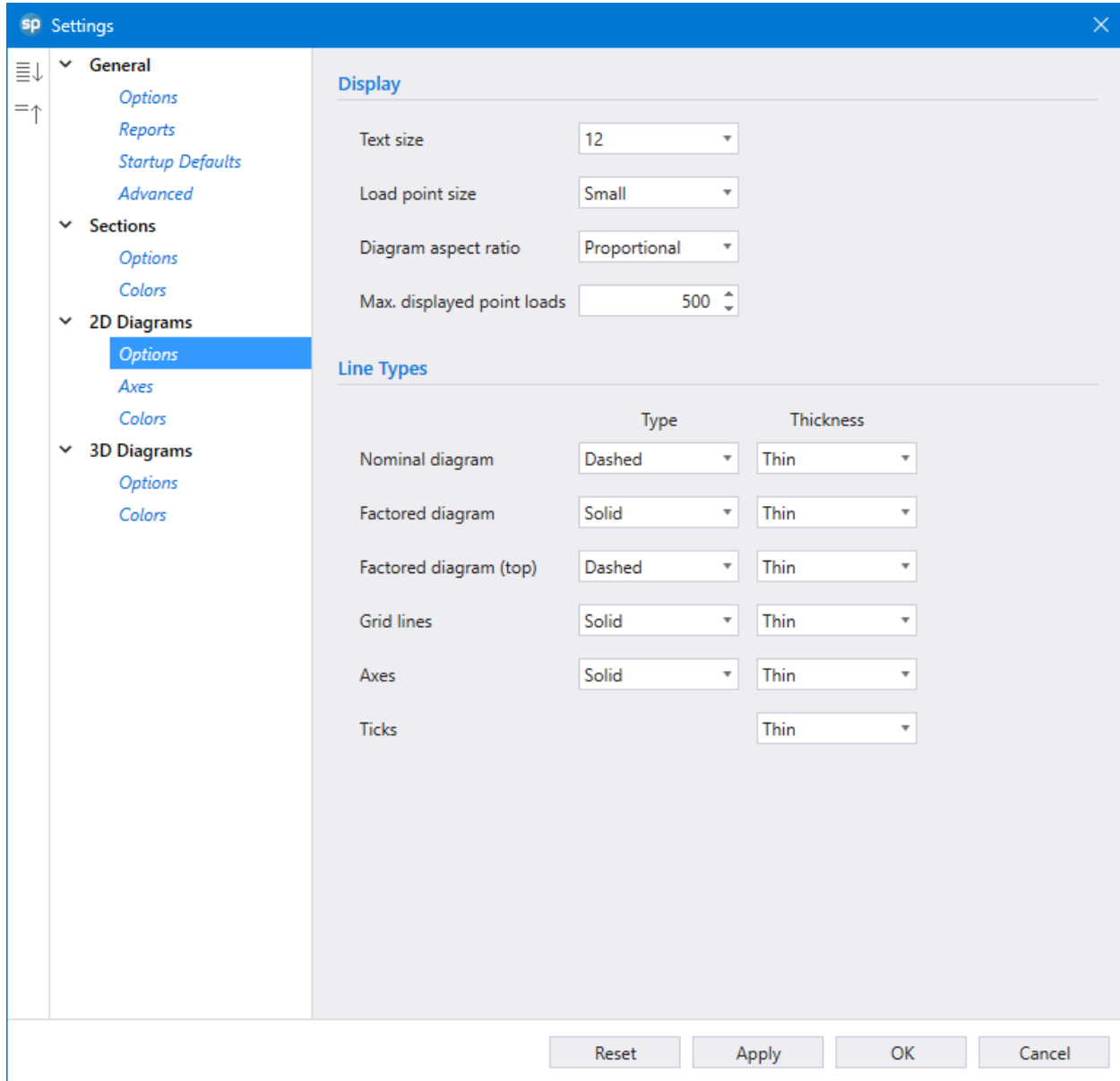

## Options

### **Display**

Text size – Option to select text size for text in 2D diagrams.

Load point size - Small, medium and large size options for load points in 2D diagrams.

Diagram aspect ratio - Diagram aspect ratio - 1:1 or Auto diagram aspect ratios for 2D diagrams

Max. displayed point loads – The maximum number of load points to be displayed in the viewports. 500 by default, maximum value is 10000.

### **Line Types**

Options for line types and line thicknesses for nominal diagram, factored diagram, factored diagram (top), grid lines, axes and ticks.

## Axes

### **Axes**

Axis values - Provides the option to show labels for all ticks on axes or only for ticks representing maximum values in axes.

Uniform “axis values” for M-M diagrams - When checked, all MM diagrams have the same maximum value in each axis making comparisons between different contours easier.

Uniform “axis values” for P-M diagrams - When checked, all MM diagrams have the same maximum value in each axis making comparisons between different interaction diagrams easier.

## Colors

### **Diagrams**

Color options for factored diagram, nominal diagram and splice lines

### **Load Points**

Color options for load points inside the diagram, load points outside the diagram, selected load points and load points with cursor hovering over them.

### **Misc.**

Color options for grid lines, axes and screen background.

### 7.3.3. Settings – 3D Diagram

Provides users with the options to modify Options and Colors for 3D diagrams.

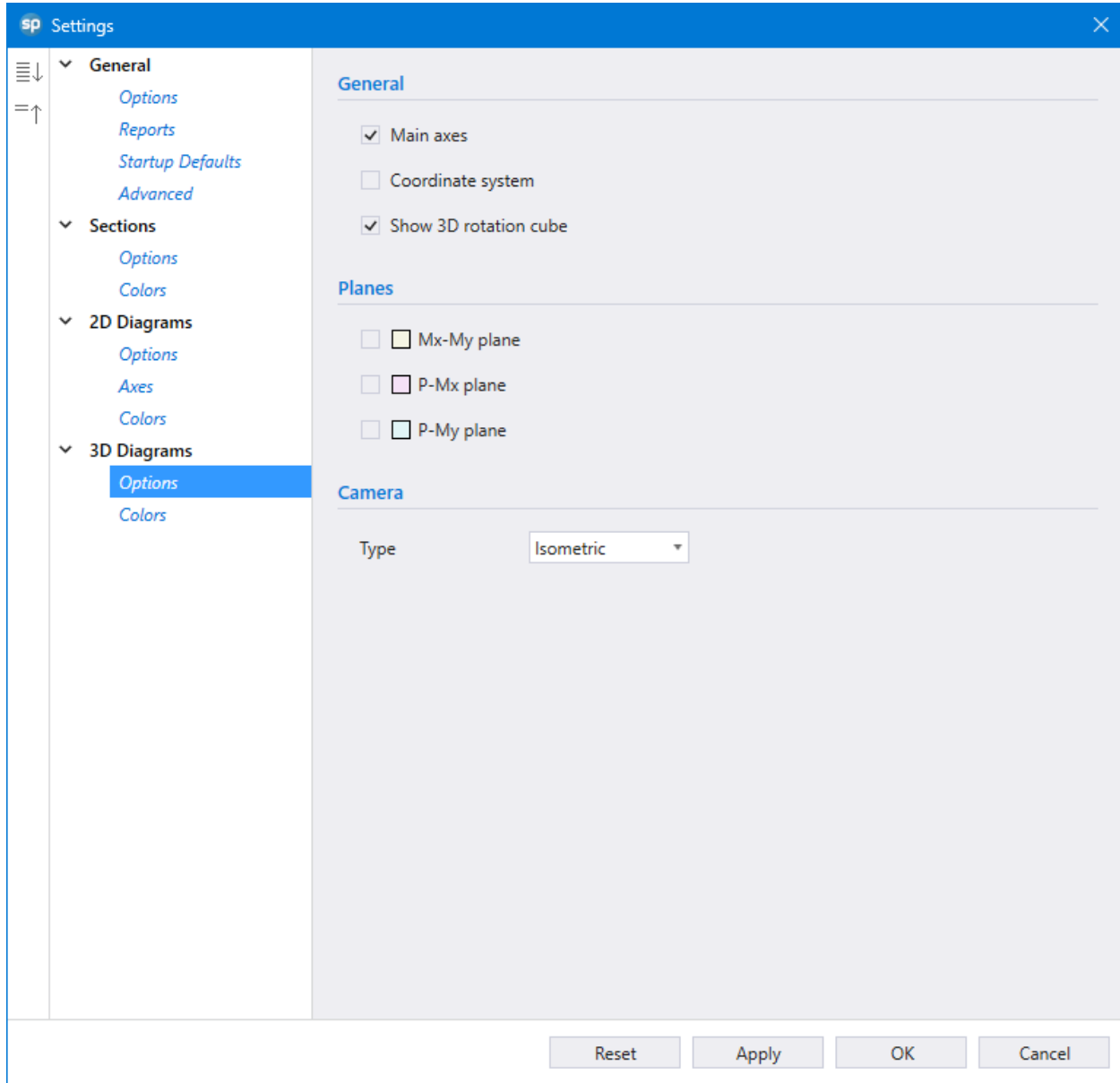

## Options

### **General**

Options to Show/Hide 3D diagram main axes, 3D diagram coordinate system and the 3D rotation cube.

### **Planes**

Options to Show/Hide 3D  $M_x$ - $M_y$ ,  $P$ - $M_x$  and  $P$ - $M_y$  planes.

### **Camera**

Option to switch between perspective and isometric camera types.

## Colors

### **Factored Surface**

Color, opacity and line size options for factored surface

### **Nominal Surface**

Color, opacity and line size options for nominal surface

### **Load Points**

Color and size options for load points inside the diagram, load points outside the diagram, selected load points and load points with cursor hovering over them.

### **Main Axes Planes**

Color and opacity options for  $M_x$ - $M_y$ ,  $P$ - $M_x$  and  $P$ - $M_y$  planes

### **Axes**

Color and opacity options for X, Y and Z axes

### **Cutter Plane**

Color and opacity options for cutter plane

CHAPTER  
A

APPENDIX

---

A.1. Default Load Case and Combination Factors .....	167
A.2. Import File Formats .....	172
A.2.1. Service Loads Data.....	173
A.2.2. Factored Loads Data.....	174
A.2.3. Reinforcement Data.....	175
A.2.4. Geometry Data.....	176
A.3. spColumn Text Input (CTI) file format .....	178
A.4. Exporting XML Model Data File from ETABS .....	203
A.5. Conversion Factors - English to SI .....	205
A.6. Conversion Factors - SI to English .....	206
A.7. Material Strength Value Limits.....	207
A.8. Technical Resources .....	208
A.9. Contact Information .....	209
A.10. Technical Manual Revision History .....	210

---

## A.1. Default Load Case and Combination Factors

---

spColumn allows defining up to 50 load combinations. The user has full control over the combinations. The program contains predefined (built into the program) default primary load combinations for the supported codes. These default combinations are created when starting a new project. The default load combinations of the Dead (D), Live (L), Wind (W), Earthquake (E) and Snow (S) loads considered by the program are shown below.

For the ACI 318-19, 14, 11 codes<sup>1</sup>:

$$U1 = 1.4D$$

$$U2 = 1.2D + 1.6L + 0.5S$$

$$U3 = 1.2D + 1L + 1.6S$$

$$U4 = 1.2D + 0.5W + 1.6S$$

$$U5 = 1.2D - 0.5W + 1.6S$$

$$U6 = 1.2D + 1L + 1W + 0.5S$$

$$U7 = 1.2D + 1L - 1W + 0.5S$$

$$U8 = 1.2D + 1L + 1E + 0.2S$$

$$U9 = 1.2D + 1L - 1E + 0.2S$$

$$U10 = 0.9D + 1W$$

$$U11 = 0.9D - 1W$$

$$U12 = 0.9D + 1E$$

$$U13 = 0.9D - 1E$$

---

<sup>1</sup> ACI 318-19, 5.3; ACI 318-14, 5.3; ACI 318-11, 9.2; (Assuming W and E based on ultimate-level forces)

For the ACI 318-08, 05 and 02 codes<sup>2</sup>:

$$U1 = 1.4D$$

$$U2 = 1.2D + 1.6L + 0.5S$$

$$U3 = 1.2D + 1L + 1.6S$$

$$U4 = 1.2D + 0.8W + 1.6S$$

$$U5 = 1.2D - 0.8W + 1.6S$$

$$U6 = 1.2D + 1L + 1.6W + 0.5S$$

$$U7 = 1.2D + 1L - 1.6W + 0.5S$$

$$U8 = 1.2D + 1L + 1E + 0.2S$$

$$U9 = 1.2D + 1L - 1E + 0.2S$$

$$U10 = 0.9D + 1.6W$$

$$U11 = 0.9D - 1.6W$$

$$U12 = 0.9D + 1E$$

$$U13 = 0.9D - 1E$$

---

<sup>2</sup> ACI 318-08, 9.2; ACI 318-05, 9.2; ACI 318-02, 9.2; (Assuming W based on service-level wind load and E based on ultimate-level forces)

For CSA A23.3-19 and CSA A23.3-14 codes<sup>3</sup>:

$$U1 = 1.4D$$

$$U2 = 1.25D + 1.5L + 1S$$

$$U3 = 0.9D + 1.5L + 1S$$

$$U4 = 1.25D + 1.5L + 0.4W$$

$$U5 = 1.25D + 1.5L - 0.4W$$

$$U6 = 0.9D + 1.5L + 0.4W$$

$$U7 = 0.9D + 1.5L - 0.4W$$

$$U8 = 1.25D + 1L + 1.5S$$

$$U9 = 0.9D + 1L + 1.5S$$

$$U10 = 1.25D + 0.4W + 1.5S$$

$$U11 = 1.25D - 0.4W + 1.5S$$

$$U12 = 0.9D + 0.4W + 1.5S$$

$$U13 = 0.9D - 0.4W + 1.5S$$

$$U14 = 1.25D + 0.5L + 1.4W$$

$$U15 = 1.25D + 0.5L - 1.4W$$

$$U16 = 1.25D + 1.4W + 0.5S$$

$$U17 = 1.25D - 1.4W + 0.5S$$

$$U18 = 0.9D + 0.5L + 1.4W$$

$$U19 = 0.9D + 0.5L - 1.4W$$

$$U20 = 0.9D + 1.4W + 0.5S$$

$$U21 = 0.9D - 1.4W + 0.5S$$

$$U22 = 1D + 0.5L + 1E + 0.25S$$

$$U23 = 1D + 0.5L - 1E + 0.25S$$

---

<sup>3</sup> CSA A23.3-14/19 Annex C, Table C1; NBCC 2010 [10], Table 4.1.3.2A

For the CSA A23.3-04 code<sup>4</sup>:

$$U1 = 1.4D$$

$$U2 = 1.25D + 1.5L + 0.5S$$

$$U3 = 0.9D + 1.5L + 0.5S$$

$$U4 = 1.25D + 1.5L + 0.4W$$

$$U5 = 1.25D + 1.5L - 0.4W$$

$$U6 = 0.9D + 1.5L + 0.4W$$

$$U7 = 0.9D + 1.5L - 0.4W$$

$$U8 = 1.25D + 0.5L + 1.5S$$

$$U9 = 0.9D + 0.5L + 1.5S$$

$$U10 = 1.25D + 0.4W + 1.5S$$

$$U11 = 1.25D - 0.4W + 1.5S$$

$$U12 = 0.9D + 0.4W + 1.5S$$

$$U13 = 0.9D - 0.4W + 1.5S$$

$$U14 = 1.25D + 0.5L + 1.4W$$

$$U15 = 1.25D + 0.5L - 1.4W$$

$$U16 = 1.25D + 1.4W + 0.5S$$

$$U17 = 1.25D - 1.4W + 0.5S$$

$$U18 = 0.9D + 0.5L + 1.4W$$

$$U19 = 0.9D + 0.5L - 1.4W$$

$$U20 = 0.9D + 1.4W + 0.5S$$

$$U21 = 0.9D - 1.4W + 0.5S$$

$$U22 = 1D + 0.5L + 1E + 0.25S$$

$$U23 = 1D + 0.5L - 1E + 0.25S$$

---

<sup>4</sup> CSA A23.3-04, 8.3.2; CSA A23.3-04, Annex C, Table C1; NBCC 2005 [10], Table 4.1.3.2

For the CSA A23.3-94 code<sup>5</sup>:

$$U1 = 1.25D$$

$$U2 = 1.25D + 1.5L + 1.5S$$

$$U3 = 0.85D + 1.5L + 1.5S$$

$$U4 = 1.25D + 1.05L + 1.05W + 1.05S$$

$$U5 = 1.25D + 1.05L - 1.05W + 1.05S$$

$$U6 = 0.85D + 1.05L + 1.05W + 1.05S$$

$$U7 = 0.85D + 1.05L - 1.05W + 1.05S$$

$$U8 = 1.25D + 1.5W$$

$$U9 = 1.25D - 1.5W$$

$$U10 = 0.85D + 1.5W$$

$$U11 = 0.85D - 1.5W$$

$$U12 = 1D + 1E$$

$$U13 = 1D - 1E$$

$$U14 = 1D + 0.5L + 1E + 0.5S$$

$$U15 = 1D + 0.5L - 1E + 0.5S$$

---

<sup>5</sup> CSA A23.3-94, 8.3.2 (conservatively assuming storage and assembly occupancies)

## A.2. Import File Formats

---

Geometry, reinforcement or load data may be imported from a text file. The import file must be saved in pure ASCII (text) format. Data fields on each line should be separated by spaces or TABs.

Import data for geometry, reinforcement and loads can all be stored in separate files or it can be stored as individual datasets in a single text file. While using a single file, each dataset should be preceded by the correct keyword. It is also possible to add comment lines (lines beginning with // and followed by comment text) or blank lines in an import file, however, these should only be added at the beginning or the end of a dataset; adding them in the middle of a dataset is not supported.

Samples text files are provided as a reference for the user to preview and edit as needed here:  
C:\Program Files (x86)\StructurePoint\spColumn\Examples\Examples-Import File

### A.2.1. Service Loads Data

Each service load point has five lines of data (one line for each load case, i.e. Dead, Live, Wind, Earthquake and Snow). Each data line has five values. For a service load point  $i$ :

$P_{i\_D}$	Axial load
$M_{i\_DT}$	$M_x$ at top
$M_{i\_DB}$	$M_x$ at bottom
$M_{i\_DT}$	$M_y$ at top
$M_{i\_DB}$	$M_y$ at bottom

Example:

```

SERVICELoads          // Keyword
2                      // Number of load points
10 20 30 40 50       // P1_D  M1x_DT  M1x_DB  M1y_DB  M1y_DB
11 21 31 41 51       // P1_L  M1x_LT  M1x_LB  M1y_LT  M1y_LB
12 22 32 42 52       // P1_W  M1x_WT  M1x_WB  M1y_WT  M1y_WB
13 23 33 43 53       // P1_EQ M1x_EQT M1x_EQB M1y_EQT M1y_EQB
14 24 34 44 54       // P1_S  M1x_ST  M1x_SB  M1y_ST  M1y_SB
10 20 30 40 50       // P2_D  M2x_DT  M2x_DB  M2y_DB  M2y_DB
11 21 31 41 51       // P2_L  M2x_LT  M2x_LB  M2y_LT  M2y_LB
12 22 32 42 52       // P2_W  M2x_WT  M2x_WB  M2y_WT  M2y_WB
13 23 33 43 53       // P2_EQ M2x_EQT M2x_EQB M2y_EQT M2y_EQB
14 24 34 44 54       // P2_S  M2x_ST  M2x_SB  M2y_ST  M2y_SB
    
```

The notations D, L, W, EQ, and S designate the Dead, Live, Wind, Earthquake, and Snow load cases, respectively.

## A.2.2. Factored Loads Data

For a factored load point  $i$ :

$P_i$             Factored axial load,  
 $M_{ix}$            Factored moment about x and  
 $M_{iy}$            Factored moment about y

Example:

```

FACTOREDLOADS        // Keyword
4                     // Number of load points
10 20 30             // P1   M1x   M1y
11 21 31             // P2   M2x   M2y
12 22 32             // P3   M3x   M3y
13 23 33             // P4   M4x   M4y
  
```

### A.2.3. Reinforcement Data

For a reinforcement bar  $i$ :

$A_i$  Bar area,

$X_i$  X-coordinate and

$Y_i$  Y-coordinate

Example:

```

REINFORCEMENT           // Keyword
4                         // Number of reinforcement bars
0.79 -5.625  5.625      // A1  X1  Y1
0.79 -5.625 -5.625     // A3  X3  Y3
0.79 -5.625 -5.625     // A3  X3  Y3
0.79  5.625 -5.625     // A4  X4  Y4
  
```

### A.2.4. Geometry Data

In spColumn 10.00 a section can consist of one or multiple solids and openings. Given a section, for a solid in it  $s_i$  with node  $s_{i\_i}$

$X_{s_{i\_i}}$  X-coordinate of the node

$Y_{s_{i\_i}}$  Y-coordinate of the node

For an opening in it  $o_i$  with node  $o_{i\_i}$

$X_{o_{i\_i}}$  X-coordinate of the node

$Y_{o_{i\_i}}$  Y-coordinate of the node

If the section does not contain an opening, the value of number of opening should be given as 0.

## Example:

```

SOLIDS                                // Keyword
2                                     // Number solid shapes
5                                     // Number of nodes in the 1st solid shape
-8.0000 -8.0000                       // Xs1_1  Ys1_1
-8.0000  8.0000                       // Xs1_2  Ys1_2
 8.0000  8.0000                       // Xs1_3  Ys1_3
 8.0000 -8.0000                       // Xs1_4  Ys1_4
-8.0000 -8.0000                       // Xs1_5  Ys1_5
5                                     // Number of nodes in the 2nd solid shape
13.0000 -8.0000                       // Xs2_1  Ys2_1
13.0000  8.0000                       // Xs2_2  Ys2_2
29.0000  8.0000                       // Xs2_3  Ys2_3
29.0000 -8.0000                       // Xs2_4  Ys2_4
13.0000 -8.0000                       // Xs2_5  Ys2_5
OPENINGS                              // Keyword
1                                     // Number of openings
5                                     // Number of nodes in the 1st opening
-3.0000 -3.0000                       // Xo1_1  Yo1_1
 3.0000 -3.0000                       // Xo1_2  Yo1_2
 3.0000  3.0000                       // Xo1_3  Yo1_3
-3.0000  3.0000                       // Xo1_4  Yo1_4
-3.0000 -3.0000                       // Xo1_5  Yo1_5
  
```

---

### A.3. spColumn Text Input (CTI) file format

---

spColumn is able to read three file formats, COL, COLX and CTI and save its input data into two file formats, COLX file or CTI file. CTI files are plain text files that can be edited by any text editing software.

Caution must be used when editing a CTI file because some values may be interrelated. If one of these values is changed, then other interrelated values should be changed accordingly. While this is done automatically when a model is edited in the spColumn user graphic user interface (GUI), one must update all the related values in a CTI file manually in order to obtain correct results. For example, if units are changed from English to Metric in GUI, all the related input values are updated automatically. If this is done by editing a CTI file, however, not only the unit flag but also all the related input values must be updated manually.

The best way to create a CTI file is by using the spColumn GUI and selecting CTI file type in the Save As menu command. Then, any necessary modifications to the CTI file can be applied with any text editor. However, it is recommended that users always verify modified CTI files by loading them in the spColumn GUI to ensure that the modifications are correct before running manually revised CTI files in batch mode.

The CTI file is organized by sections. Each section contains a title in square brackets, followed by values required by the section. The CTI file contains the following sections.

```
[spColumn Version]
[Project]
[Column ID]
[Engineer]
[Investigation Run Flag]
[Design Run Flag]
[Slenderness Flag]
[User Options]
[Irregular Options]
[Ties]
[Investigation Reinforcement]
```

[Design Reinforcement]  
[Investigation Section Dimensions]  
[Design Section Dimensions]  
[Material Properties]  
[Reduction Factors]  
[Design Criteria]  
[External Points]  
[Internal Points]  
[Reinforcement Bars]  
[Factored Loads]  
[Slenderness: Column]  
[Slenderness: Column Above And Below]  
[Slenderness: Beams]  
[EI]  
[SldOptFact]  
[Phi\_Delta]  
[Cracked I]  
[Service Loads]  
[Load Combinations]  
[BarGroupType]  
[User Defined Bars]  
[Sustained Load Factors]

Each section of a CTI file and allowable values of each parameter are described in details below. Corresponding GUI commands are presented in parenthesis.

#spColumn Text Input (CTI) File

The number sign, #, at the beginning of a line of text indicates that the line of text is a comment. The # sign must be located at the beginning of a line. Comments may be added anywhere necessary in a CTI file to make the file more readable. If a comment appears in multiple lines, each line must be started with a # sign

[spColumn Version]

Reserved. Do not edit.

[Project]

There is one line of text in this section.

Project name (Project left panel | Description)

[Column ID]

There is one line of text in this section.

Column ID (Project left panel | Description)

[Engineer]

There is one line of text in this section.

Engineer name (Project left panel | Description)

[Investigation Run Flag]

Reserved. Do not edit.

[Design Run Flag]

Reserved. Do not edit.

[Slenderness Flag]

Reserved. Do not edit.

---

[User Options]

There are 27 values separated by commas in one line in this section. These values are described below in the order they appear from left to right.

1. 0-Investigation Mode; 1-Design Mode; (Run Option in Project left panel | Run Options)
2. 0-English Unit; 1-Metric Units; (Unit system in Project left panel | General)
3. 0-ACI 318-02; 1- CSA A23.3-94; 2-ACI 318-05; 3-CSA A23.3-04; 4-ACI 318-08; 5-ACI 318-11; 6-ACI 318-14; 7-CSA A23.3-14; 8-ACI 318-19; 9-CSA A23.3-19 (Design Code in Project left panel | General)
4. 0-X Axis Run; 1-Y Axis Run; 2-Biaxial Run; (Run Axis in Project left panel | Run Options)
5. Reserved. Do not edit.
6. 0-Slenderness is not considered; 1-Slenderness is considered; (Consider Slenderness in Project left panel | Run Options)
7. 0-Design for minimum number of bars; 1-Design for minimum area of reinforcement; (Bar selection in Definitions dialog | Properties | Design Criteria | Reinforcement Bars)
8. Reserved. Do not edit.
9. 0-Rectangular Column Section; 1-Circular Column Section; 2-Irregular Column Section; (Section left panel)
10. 0-Rectangular reinforcing bar layout; 1-Circular reinforcing bar layout; (Layout in Section left panel | Rect. Or Cir. | Bar Arrangement - when Type is All Sides Equal)
11. 0-Structural Column Section; 1-Architectural Column Section; 2-User Defined Column Section; (Column Type in Definitions dialog | Properties | Design Criteria)
12. 0-Tied Confinement; 1-Spiral Confinement; 2-Other Confinement; (Confinement in Definitions dialog | Properties | Reduction Factors | Confinement)

13. Load type for investigation mode: (Loads dialog) 0-Factored; 1-Service; 2-Control Points; 3-Axial Loads
14. Load type for design mode: (Loads dialog)
  - 0-Factored; 1-Service; 2-Control Points; 3-Axial Loads
15. Reinforcement layout for investigation mode: (Layout in Section left panel | Rect. Or Cir. Bar Arrangement) 0-All Side Equal; 1-Equal Spacing; 2-Sides Different; 3-Irregular Pattern
16. Reinforcement layout for design mode: (Layout in Section left panel | Rect. Or Cir. Bar Arrangement)
  - 0-All Side Equal; 1-Equal Spacing; 2-Sides Different; 3-Irregular Pattern
17. Reserved. Do not edit for regular bars. No of bars for irregular bars.
18. Number of factored loads (Factored Loads in Loads dialog | Loads)
19. Number of service loads (Service Loads in Loads dialog | Loads)
20. If there is only one exterior column section then Number of points on exterior column section. If there are more than one exterior column sections then 0.
21. If there is only one interior section opening then Number of points on the interior section opening. If there are more than one interior section openings then 0.
22. Reserved. Do not edit.
23. Reserved. Do not edit.
24. Cover type for investigation mode: (Clear cover to in Section left panel | Rect. Or Cir. | Cover Type) 0-To transverse bar; 1-To longitudinal bar
25. Cover type for design mode: (Clear cover to in Section left panel | Rect. Or Cir. | Cover Type) 0-To transverse bar; 1-To longitudinal bar

26. Number of load combinations; (Load combinations in Definitions dialog | Load Case/Combo)
27. Section capacity: 0-Moment capacity method; 1-Critical Capacity method; (Section capacity in Project left panel | General)

#### [Irregular Options]

There are 13 values separated by commas in one line in this section. These values are described below in the order they appear from left to right. (Section left panel | Irregular)

1. Reserved. Do not edit.
2. Reserved. Do not edit.
3. Reserved. Do not edit.
4. Reserved. Do not edit.
5. Area of reinforcing bar that is to be added through irregular section editor
6. Maximum X value of drawing area of irregular section editor
7. Maximum Y value of drawing area of irregular section editor
8. Minimum X value of drawing area of irregular section editor
9. Minimum Y value of drawing area of irregular section editor
10. Grid step in X of irregular section editor
11. Grid step in Y of irregular section editor
12. Grid snap step in X of irregular section editor
13. Grid snap step in Y of irregular section editor

### [Ties]

There are 3 values separated by commas in one line in this section. These values are described below in the order they appear from left to right. (Section left panel | Rect. or Cir. | Cover Type)

1. Index (0 based) of tie bars for longitudinal bars smaller than the one specified in the 3<sup>rd</sup> item in this section in the drop-down list
2. Index (0 based) of tie bars for longitudinal bars bigger than the one specified in the 3<sup>rd</sup> item in this section in the drop-down list
3. Index (0 based) of longitudinal bar in the drop-down list

### [Investigation Reinforcement]

This section applies to investigation mode only. There are 12 values separated by commas in one line in this section. These values are described below in the order they appear from left to right.

If Side Different (Type is Sides Different in Section left panel | Rect. | Bar Arrangement) is selected:

1. Number of top bars
2. Number of bottom bars
3. Number of left bars
4. Number of right bars
5. Index (0 based) of top bars (Top Bar Size drop-down list)
6. Index (0 based) of bottom bars (Bottom Bar Size drop-down list)
7. Index (0 based) of left bars (Left Bar Size drop-down list)
8. Index (0 based) of right bars (Right Bar Size drop-down list)

9. Clear cover to top bars
10. Clear cover to bottom bars
11. Clear cover to left bars
12. Clear cover to right bars

If All Sides Equal (Type is All Sides Equal in Section left panel | Rect. Or Cir. | Bar Arrangement) or Equal Spacing (Type is Equal Spacing in Section left panel | Rect. | Bar Arrangement) is selected:

1. Number of bars (No. of Bars text box)
2. Reserved. Do not edit.
3. Reserved. Do not edit.
4. Reserved. Do not edit.
5. Index (0 based) of bar (Bar Size drop-down list)
6. Reserved. Do not edit.
7. Reserved. Do not edit.
8. Reserved. Do not edit.
9. Clear cover to bar (Clear Cover text box)
10. Reserved. Do not edit.
11. Reserved. Do not edit.
12. Reserved. Do not edit.

If Irregular Pattern (Section left panel | Irregular) is selected: Reserved. Do not edit.

[Design Reinforcement]

This section applies to design mode only. There are 12 values separated by commas in one line in this section. These values are described below in the order they appear from left to right.

If Side Different (Type is Sides Different in Section left panel | Rect. | Bar Arrangement) is selected:

1. Minimum number of top and bottom bars
2. Maximum number of top and bottom bars
3. Minimum number of left and right bars
4. Maximum number of left and right bars
5. Index (0 based) of minimum size for top and bottom bars
6. Index (0 based) of maximum size for top and bottom bars
7. Index (0 based) of minimum size for left and right bars
8. Index (0 based) of maximum size for left and right bars
9. Clear cover to top and bottom bars
10. Reserved. Do not edit.
11. Clear cover to left and right bars
12. Reserved. Do not edit.

If All Sides Equal (Type is All Sides Equal in Section left panel | Rect. Or Cir. | Bar Arrangement) or Equal Spacing (Type is Equal Spacing in Section left panel | Rect. | Bar Arrangement) is selected:

1. Minimum number of bars
2. Maximum number of bars
3. Reserved. Do not edit.
4. Reserved. Do not edit.
5. Index (0 based) of minimum size of bars
6. Index (0 based) of maximum size of bars
7. Reserved. Do not edit.
8. Reserved. Do not edit.
9. Clear cover
10. Reserved. Do not edit.
11. Reserved. Do not edit.
12. Reserved. Do not edit.

### [Investigation Section Dimensions]

This section applies to investigation mode only. There are 2 values separated by commas in one line in this section. These values are described below in the order they appear from left to right.

If rectangular section (Section left panel | Rect.) is selected:

1. Section width (along X)
2. Section depth (along Y)

If circular section (Section left panel | Cir.) is selected:

1. Section diameter
2. Reserved. Do not edit.

If irregular section (Section left panel | Irregular) is selected:

1. Reserved. Do not edit.
2. Reserved. Do not edit.

[Design Section Dimensions]

This section applies to design mode only. There are 6 values separated by commas in one line in this section. These values are described below in the order they appear from left to right.

If rectangular section (Section left panel | Rect.) is selected:

1. Section width (along X) Start
2. Section depth (along Y) Start
3. Section width (along X) End
4. Section depth (along Y) End
5. Section width (along X) Increment
6. Section depth (along Y) Increment

If circular section (Section left panel | Cir.) is selected:

1. Diameter start
2. Reserved. Do not change.
3. Diameter end
4. Reserved. Do not change.
5. Diameter increment
6. Reserved. Do not change.

[Material Properties]

There are 11 values separated by commas in one line in this section. These values are described below in the order they appear from left to right. (Concrete and Reinforcing Steel in Definitions dialog | Properties)

1. Concrete strength,  $f'_c$
2. Concrete modulus of elasticity,  $E_c$
3. Concrete maximum stress,  $f_c$
4. Beta (1) for concrete stress block
5. Concrete ultimate strain
6. Steel yield strength,  $f_y$
7. Steel modulus of elasticity,  $E_s$
8. Precast material for concrete. Only applicable for CSA A23.3-14 and CSA A23.3-04. 0-non-precast; 1-Precast
9. Standard material for concrete 0-Non-standard; 1-Standard
10. Standard material for reinforcing steel 0-Non-standard; 1-Standard
11. Compression-controlled strain limit

### [Reduction Factors]

There are 5 values separated by commas in one line in this section. These values are described below in the order they appear from left to right. (Capacity Reduction Factors/Material Resistance Factors in Definitions dialog | Properties | Reduction Factors)

1.  $\Phi(a)$  for axial compression
2.  $\Phi(b)$  for tension-controlled failure
3.  $\Phi(c)$  for compression-controlled failure
4. Reserved. Do not edit
5. Minimum dimension of tied irregular sections for CSA A23.3-14 and CSA A23.3-19; 0- for all other cases

### [Design Criteria]

There are 4 values separated by commas in one line in this section. These values are described below in the order they appear from left to right. (Reinforcement Ratio, Reinforcement Bars and Capacity Ratio in Definitions dialog | Properties | Reduction Factors)

1. Minimum reinforcement ratio
2. Maximum reinforcement ratio
3. Minimum clear spacing between bars
4. Allowable Capacity (Ratio)

### [External Points]

This section applies to irregular section in investigation mode only. The first line contains the number of solids. The second line contains the number of points on the perimeter of the first solid. Each of the following lines contains 2 values: X and Y coordinates (separated by comma) of a point. The number of points on the perimeter of the solid and the values of X and Y coordinates are listed one after the other for each solid present. The coordinates provided should be such that no two solids should overlap.

```

Number of solids
Number of Points in 1st solid, n1
Point_1_X, Point_1_Y
Point_2_X, Point_2_Y...
Point_n1_X, Point_n1_Y
Number of Points in 2nd solid, n2
Point_1_X, Point_1_Y
Point_2_X, Point_2_Y...
Point_n2_X, Point_n2_Y
  
```

### [Internal Points]

This section applies to irregular section in investigation mode only. The first line contains the number of openings. The second line contains the number of points on the perimeter of the first opening. Each of the following lines contains 2 values: X and Y coordinates (separated by comma) of a point. The number of points on the perimeter of the opening and the values of X and Y coordinates are listed one after the other for each opening present. If no openings exist, then the first line (Number of openings) must be 0. The coordinates provided should be such that no two openings overlap and an opening is completely inside a solid.

```

Number of openings
Number of Points in 1st opening, n1
Point_1_X, Point_1_Y
Point_2_X, Point_2_Y...
Point_n1_X, Point_n1_Y
Number of Points in 2nd opening, n2
Point_1_X, Point_1_Y
Point_2_X, Point_2_Y...
Point_n2_X, Point_n2_Y
  
```

### [Reinforcement Bars]

This section applies to irregular section in investigation mode only. The first line contains the number of reinforcing bars. Each of the following lines contains 3 values: area, X and Y coordinates (separated by comma) of a bar.

```

Number of bars,
n Bar_1_area, Bar_1_X, Bar_1_Y
Bar_2_area, Bar_2_X, Bar_2_Y
...
Bar_n_area, Bar_n_X, Bar_n_Y
  
```

### [Factored Loads]

The first line contains the number of factored loads defined. Each of the following lines contains 3 values: axial load, X-moment, and Y-moment separated by commas. (Factored Loads in Loads dialog | Loads)

```
Number of Factored Loads, n  
Load_1, X-Moment_1, Y-Moment_1  
Load_2, X-Moment_2, Y-Moment_2  
...  
Load_n, X-Moment_n, Y-Moment_n
```

---

[Slenderness: Column]

This section contains 2 lines describing slenderness parameters for column being designed. The first line is for X-axis parameters, and the second line is for Y-axis parameters.

There are 9 values<sup>6</sup> separated by commas in each line. These values are described below in the order they appear from left to right. (Design Column X – Axis and Design Column Y – Axis in Slenderness dialog | Columns)

1. Column clear height
2. k(nonsway)
3. k(sway)
4. 0-Sway frame; 1-Nonsway frame
5. 0-Compute 'k' factors; 1-Input k factors
6.  $(\Sigma P_c)/P_c$
7.  $(\Sigma P_u)/P_u$
8. 0-Do not ignore moment magnification along column length in sway frames; 1-Ignore moment magnification along column length in sway frames. Use for ACI 318-11 and ACI 318-08 only. For all other codes the value must be 0.

---

<sup>6</sup> Value No 8 introduced in spColumn v4.60.

9. Column end conditions. Values for conditions as in the image given below

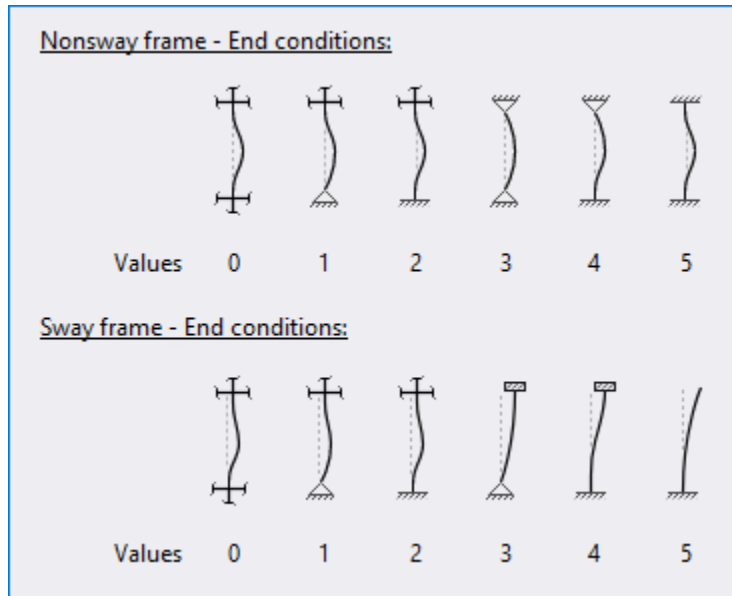

---

[Slenderness: Column Above And Below]

This section contains 2 lines describing slenderness parameters for column above and column below. The first line is for column above, and the second line is for column below. (Columns Above/Below in Slenderness dialog | Columns)

There are 6 values separated by commas in line 1 for column above. These values are described below in the order they appear from left to right.

1. 0-No column specified; 1-Circular column specified; 2-Rectangular column specified; 3-Column above section taken as design column section
2. Column Height
3. Column width (along X)
4. Column depth (along Y)
5. Concrete compressive strength,  $f'_c$
6. Concrete modulus of elasticity,  $E_c$

There are 6 values separated by commas in line 2 for column below. These values are described below in the order they appear from left to right.

1. 0-No column specified; 1-Circular column specified; 2-Rectangular column specified; 3-Column below section taken as design column section
2. Column Height
3. Column width (along X)
4. Column depth (along Y)
5. Concrete compressive strength,  $f'_c$
6. Concrete modulus of elasticity,  $E_c$

[Slenderness: Beams]

This section contains 8 lines. Each line describes a beam.

Line 1: X-Beam (perpendicular to X), Above Left

Line 2: X-Beam (perpendicular to X), Above Right

Line 3: X-Beam (perpendicular to X), Below Left

Line 4: X-Beam (perpendicular to X), Below Right

Line 5: Y-Beam (perpendicular to Y), Above Left

Line 6: Y-Beam (perpendicular to Y), Above Right

Line 7: Y-Beam (perpendicular to Y), Below Left

Line 8: Y-Beam (perpendicular to Y), Below Right

There are 7 values separated by commas for each beam in each line. (X-Beams and Y-Beams in Slenderness dialog | Beams) These values are described below in the order they appear from left to right.

1. 0-Rectangular Beam specified; 1-No beam specified; 2-Rigid beam specified
2. Beam span length (c/c)
3. Beam width
4. Beam depth
5. Beam section moment of inertia
6. Concrete compressive strength,  $f'_c$
7. Concrete modulus of elasticity,  $E_c$

[EI]

Reserved. Do not edit.

[SldOptFact]

There is 1 value in this section for slenderness factors. (Code Default and User Defined radio buttons in Slenderness dialog | Properties | Slenderness Factors)

Code default; 1-User defined

[Phi\_Delta]

There is 1 value in this section for slenderness factors. (Stiffness reduction factor in Slenderness dialog | Properties | Slenderness Factors)

Stiffness reduction factor

[Cracked I]

There are 2 values separated by commas in one line in this section. These values are described below in the order they appear from left to right. (Beams and Columns Cracked Section Coefficients in Slenderness dialog | Properties | Slenderness Factors)

1. Beam cracked section coefficient
2. Column cracked section coefficient

### [Service Loads]

This section describes defined service loads. (Service Loads in Loads dialog | Loads) The first line contains the number of service loads. Each of the following lines contains values for one service load.

There are 25 values for each service load in one Line separated by commas. These values are described below in the order they appear from left to right.

1. Dead Axial Load
2. Dead X-moment at top
3. Dead X-moment at bottom
4. Dead Y-moment at top
5. Dead Y-moment at bottom
6. Live Axial Load
7. Live X-moment at top
8. Live X-moment at bottom
9. Live Y-moment at top
10. Live Y-moment at bottom
11. Wind Axial Load
12. Wind X-moment at top
13. Wind X-moment at bottom
14. Wind Y-moment at top
15. Wind Y-moment at bottom

16. EQ. Axial Load

17. EQ. X-moment at top

18. EQ. X-moment at bottom

19. EQ. Y-moment at top

20. EQ. Y-moment at bottom

21. Snow Axial Load

22. Snow X-moment at top

23. Snow X-moment at bottom

24. Snow Y-moment at top

25. Snow Y-moment at bottom

### [Load Combinations]

This section describes defined load combinations. (Lod combinations in Definitions dialog | Load Case/Combo) The first line contains the number of load combinations. Each of the following lines contains load factors for one load combination.

```

Number of load combinations, n
Dead_1, Live_1, Wind_1, E.Q._1, Snow_1
Dead_2, Live_2, Wind_2, E.Q._2, Snow_2
...
Dead_n, Live_n, Wind_n, E.Q._n, Snow_n
  
```

### [BarGroupType]

There is 1 value in this section. (Bar Set drop-down list on menu Options | Reinforcement...)

#### 0-User Defined

1. ASTM615
2. CSA G30.18
3. prEN 10080
4. ASTM615M

### [User Defined Bars]

This section contains user-defined reinforcing bars. (Bar set in Project left panel | General) The first line contains the number of defined bars. Each of the following lines contains values for one bar separated by commas.

Number of user-defined bars, n

Bar\_1\_size, Bar\_1\_diameter, Bar\_1\_area, Bar\_1\_weight

Bar\_2\_size, Bar\_2\_diameter, Bar\_2\_area, Bar\_2\_weight

...

Bar\_n\_size, Bar\_n\_diameter, Bar\_n\_area, Bar\_n\_weight

### [Sustained Load Factors]

There are 5 values separated by commas in one line in this section. Each value respectively represents percentage of Dead, Live, Wind, EQ, and Snow load case that is considered sustained (Load Cases in Definitions dialog | Load Case/Combo.).

## A.4. Exporting XML Model Data Files from ETABS

ETABS provides the option to export database tables as Extensible Markup Language (XML) files.

From the FILE menu select EXPORT | ETABS DATABASE TABLES TO XML.

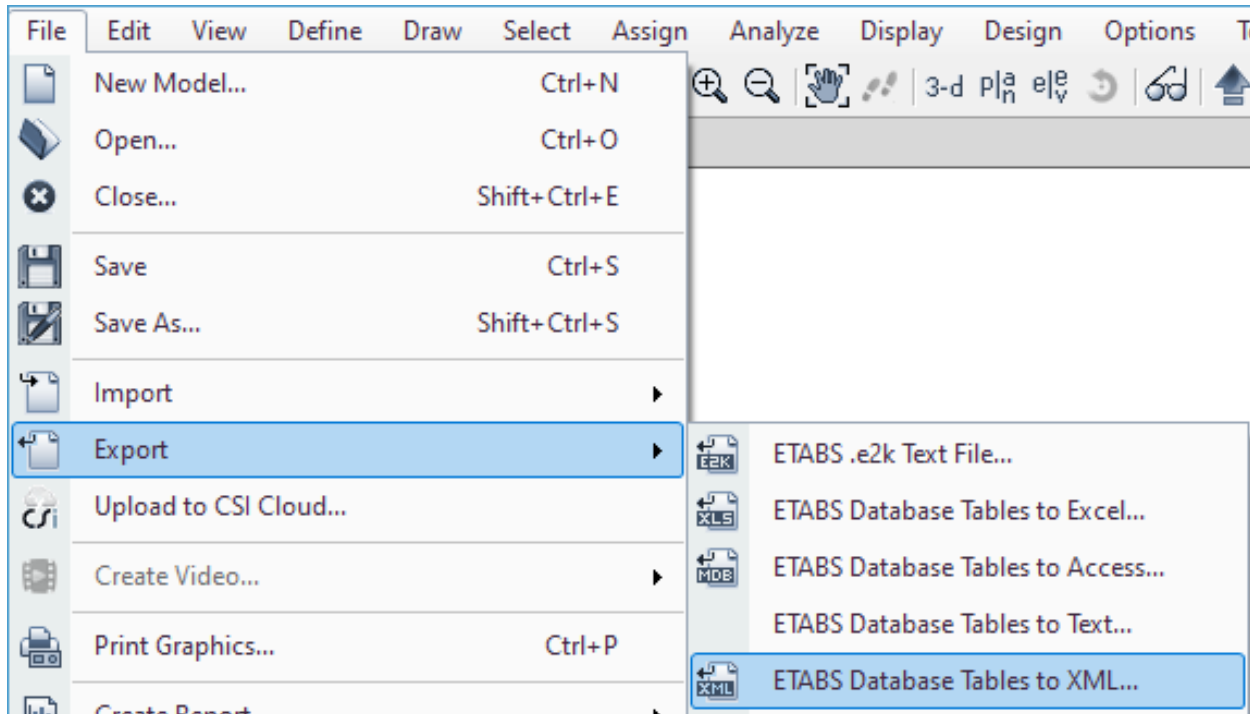

1. Make sure that all the following items are selected:

- System data
- Load Case Definitions
- Frame Assignments
- Frame Output
- Wall Output

2. Select Load Combos that need to be imported to spColumn

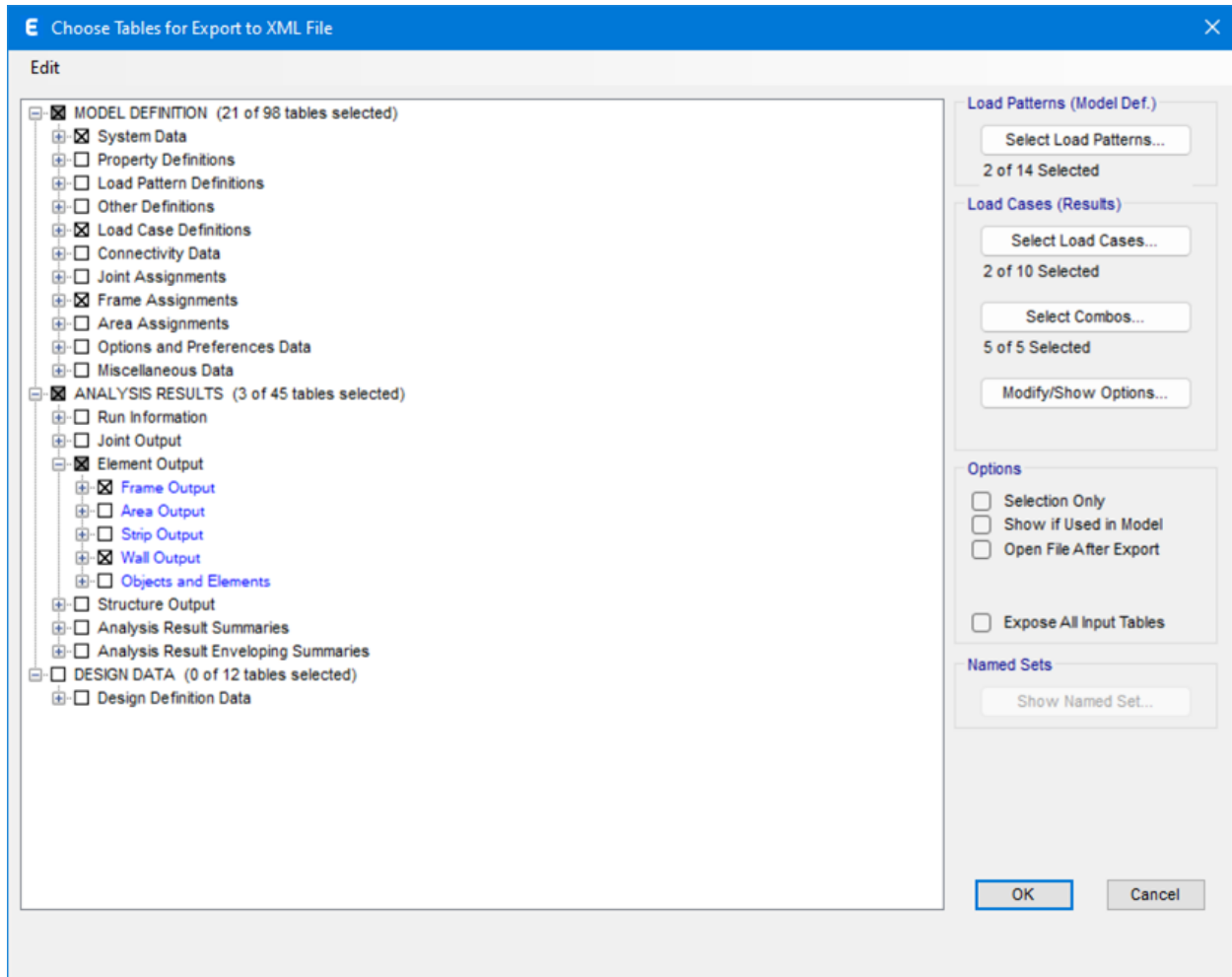

## A.5. Conversion Factors – English to SI

To convert from	To	Multiply by
in.	m (1000 mm)	0.025400
Ft	m	0.304800
Lb	N (0.001 kN)	4.448222
kip (1000 lbs)	kN	4.448222
plf (lb/ft)	N/m	14.593904
psi (lb/in. <sup>2</sup> )	kPa	6.894757
ksi (kips/in. <sup>2</sup> )	MPa	6.894757
psf (lb/ft <sup>2</sup> )	N/m <sup>2</sup> (Pa)	47.88026
pcf (lb/ft <sup>3</sup> )	kg/m <sup>3</sup>	16.018460
ft-kips	kN × m	1.355818

## A.6. Conversion Factors – SI to English

To convert from	To	Multiply by
m (1000 mm)	in	39.37008
m	ft	3.28084
N (0.001 kN)	lb	0.224809
kN	kip (1000 lbs)	0.224809
kN/m	plf (lb/ft)	68.52601
MPa	psi (lb/in <sup>2</sup> )	145.0377
MPa	ksi (kips/in <sup>2</sup> )	0.145038
kN/m <sup>2</sup> (kPa)	psf (lb/ft <sup>2</sup> )	20.88555
kg/m <sup>3</sup>	pcf (lb/ft <sup>3</sup> )	0.062428
kN × m	ft-kips	0.737562

## A.7. Material Strength Value Limits

ACI	Standard Material		Non-Standard Material	
	Min.	Max.	Min.	Max.
$f_c$	2 ksi	12 ksi	2 ksi	20 ksi
$f_y$	10 ksi	80 ksi	10 ksi	270 ksi

CSA	Standard Material		Non-Standard Material	
	Min.	Max.	Min.	Max.
$f_c$	10 MPa	80 MPa	10 MPa	150 MPa
$f_y$	100 MPa	500 MPa	100 MPa	1860 MPa

## A.8. Technical Resources

Bookstore



Technical Articles

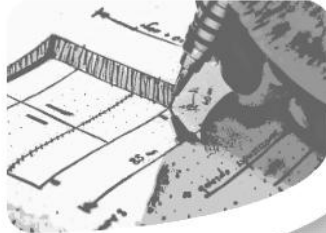

Design Examples



Case Studies



StructurePoint Wiki



Video Tutorials

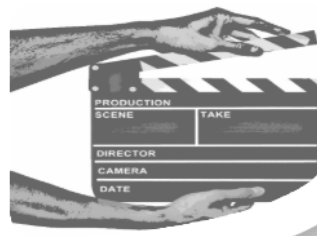

Web Applications



Technical Manuals

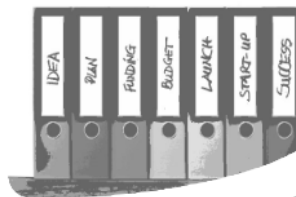

## A.9. Contact Information

---

Web Site: [www.StructurePoint.org](http://www.StructurePoint.org)

E-mail: [info@StructurePoint.org](mailto:info@StructurePoint.org)

[support@StructurePoint.org](mailto:support@StructurePoint.org)

[licensing@StructurePoint.org](mailto:licensing@StructurePoint.org)

Mailing Address: 1520 Artaius Pkwy #44  
Libertyville, IL 60048  
USA

Phone: +1-847-966-4357

Fax: +1-847-966-1542

---

## A.10. Technical Manual Revision History

---

Revision Number	Revision Approval Date	Revision Description
10.20	06-11-2025	Support spColumn v10.20 release